



M Y N A HSM

**Virtual RS3 I/O Driver
For Series 2 Simplex
Programmable Serial Interface Card**

USER MANUAL

Rev. P1.13s

April 2006

DeltaV is a trademark of Emerson Process Management, Inc © Emerson Process Management, Inc. 1998, 1999.
All rights reserved.

Printed in the U.S.A.

While this information is presented in good faith and believed to be accurate, MYNAH Technologies does not guarantee satisfactory results from reliance upon such information. *Nothing contained herein is to be construed as a warranty or guarantee, express or implied, regarding the performance, merchantability, fitness or any other matter with respect to the products*, nor as a recommendation to use any product or process in conflict with any patent. MYNAH Technologies reserves the right, without notice, to alter or improve the designs or specifications of the products described herein.



1 INTRODUCTION

1.1 Scope

This document is the User Manual for the Virtual RS3 I/O serial communication driver firmware for the Emerson Process Management (EPM) DeltaV Control System; it provides information required to install, configure, and maintain the driver firmware on the DeltaV Series 2 Programmable Serial Interface Card (PSIC). The reader should be familiar with EPM's DeltaV and RS3 controller system equipment.

The section *Document Format* briefly describes the contents of each section of this manual. *System Specifications* outlines hardware and software requirements for the Virtual RS3 I/O Driver (P1.13s) firmware.

1.2 Document Format

This document is organized as follows:

Introduction	Describes the scope and purpose of this document.
Theory of Operation	Provides a general functional overview of the Virtual RS3 I/O Driver.
Downloading Firmware	Describes downloading procedures for the Virtual RS3 I/O Driver firmware on to the DeltaV PSIC.
Configuration Information	Describes procedures and guidelines for configuring the DeltaV PSIC.
Operational Check	Provides tips and assistance to ensure PSIC is properly setup and configured.
DeltaV–RS3 Electrical Interface	Describes the electrical interface between DeltaV and the RS3 Controller. Also describes the pin assignments for RS-485 communications.
Technical Support	Describes whom to call if you need assistance.
Example	This section describes a configuration example for a single Comm Line with 4 FIMS. Note: Also included in the distribution are 3 DeltaV Module level exports, which can be imported into your DeltaV system. These modules detail mapping of AI, AO and DIO channel value and status between DeltaV I/O and PSIC dataset registers.
What's new in this Release	This section lists the differences between v1.10 and v1.13s.



1.3 System Specifications

The following table lists the minimum system requirements for the Virtual RS3 I/O Driver:

Table 1: System Specifications

Firmware	Virtual RS3 I/O Driver Firmware (P1.13s)
Protocol Compatibility	RS3 Protocol as defined in the document titled <u>RS3 Protocol as defined in the document titled RCS – Controller Software, Appendix T – Serial I/O Communications, Revision 1.31, July 27, 1998.</u>
Software Requirements	DeltaV System Software (Release 6.3 or later) installed on a hardware-appropriate Windows workstation configured as a ProfessionalPlus for DeltaV Serial Interface Port License (VE4102)
Minimum DeltaV Hardware Requirements	DeltaV Series 2 Serial Module, PN: 12P2506X022 For Simplex communications, use Termination Block PN: 12P0921X042. DeltaV M3, M5, M5+ or MD Controller, Power Supply and 8 wide controller carrier DeltaV Analog I/O Modules DeltaV Discrete I/O Modules DeltaV Bus Interface cards, e.g., H1, AS-i, Profibus and DeviceNet can also be integrated into RS3.
Minimum RS3 Hardware Requirements	MTCC or System Manager Console Control File All RS3 Controller revisions, which support Multi Channel FIM I/O, can be used with this Driver. For example MPC2, MPC+, MPC5 RS3 Comm Term Panel II. One Term Panel required for each RS3 Controller. DIN Rail Type, Part No: 01984-4205-0001



2 THEORY OF OPERATION

As part of the serial interface port license, a standard Modbus protocol is installed on the DeltaV PSIC prior to customization. The PSIC must be flash upgraded from the Modbus protocol to the Virtual RS3 I/O firmware before operation.

The Programmable Serial Interface Card (PSIC) supports RS-232, RS-422/RS-485 Half Duplex and RS-422/RS-485 Full Duplex communications with external devices. For communications with RS3 controllers, only RS-485 Half Duplex will be utilized. Consequently, a simple shielded twisted pair cable will be used for each port, allowing the PSIC to be located up to 4000ft from the RS3 Controller.

The RS-485 communication settings must be configured properly to ensure accurate communication between the PSIC and RS3 Controllers. These are described in Section 4.1.

The primary functions of the driver are listed below:

- Performs data and message handling between DeltaV and RS3 Controller devices.
- Checks validity of messages received from the RS3 Controllers.
- Processes reply information and updates the corresponding emulated DeltaV PSIC registers.
- Update emulated input channel status and Data Block status to indicate the communication status.

The DeltaV PSIC RS3 driver v1.13s operates in Simplex Slave mode only. For redundancy, driver v1.13r is required. In Slave mode, the driver receives command messages from the RS3 Controller, processes the commands, and returns data values on a message-by-message basis.

In Simplex mode, each PSIC, when loaded with the Virtual RS3 I/O Driver, is capable of communicating with RS3 over one or both of its two ports, depending upon your application. Each PSIC port, when used, is required to be wired to one of the eight available Communication lines on an RS3 Communication Termination Panel. This is shown below.

1
7

Each PSIC port can emulate a combination from one to four FIMS and either inputs or outputs (See Table 2 and 4). Within the RS3 Controller, I/O scan rates are impacted by what type of I/O is connected to the communication lines, and the Virtual RS3 I/O driver does not change those rules or scan rates from normal RS3 I/O. Please refer to the RS3 User Manuals to learn more about I/O scan rates.

Likewise, the Virtual RS3 I/O can be mixed with conventional RS3 I/O in one of two ways. First, Virtual RS3 I/O can be using dedicated Comm lines on the Communication Termination Panel. This provides the capability of 4 FIMS per Comm line (any mix of multi-channel AIO and DIO). This architecture is shown below:

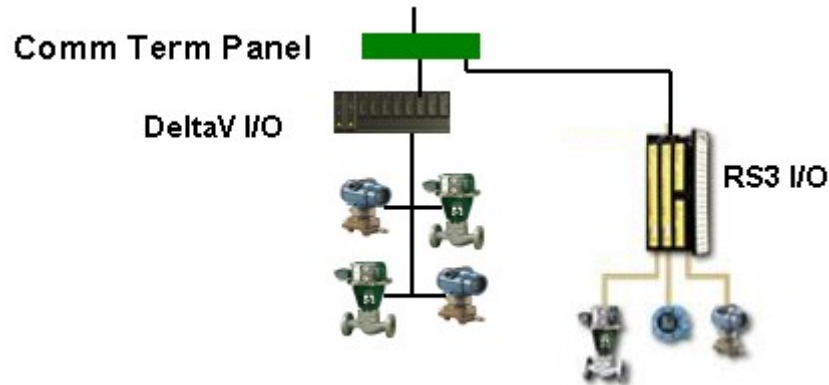

Secondly, Virtual RS3 I/O can share existing Comm lines, which already have Real RS3 I/O, attached, but with fewer than 4 FlexTerms connected. This provides the capability to bring new I/O into RS3 where physical expansion space is limited or non-existent. This architecture is as follows:

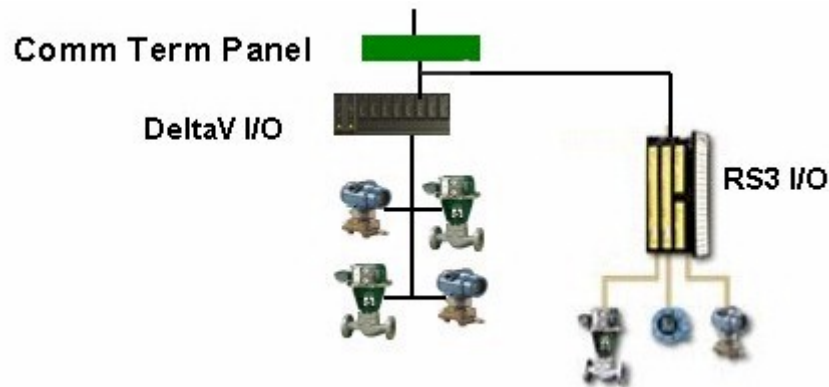

Mixing Real and Virtual RS3 I/O capability offers several advantages. First, when speed of response in a control application (such as a fast pressure loop) would not perform well using the Virtual RS3 I/O because of data latency issues. Second, when an I/O type or configuration is required, but not available in the current DeltaV I/O Modules.

At the highest level, the architecture is as shown below

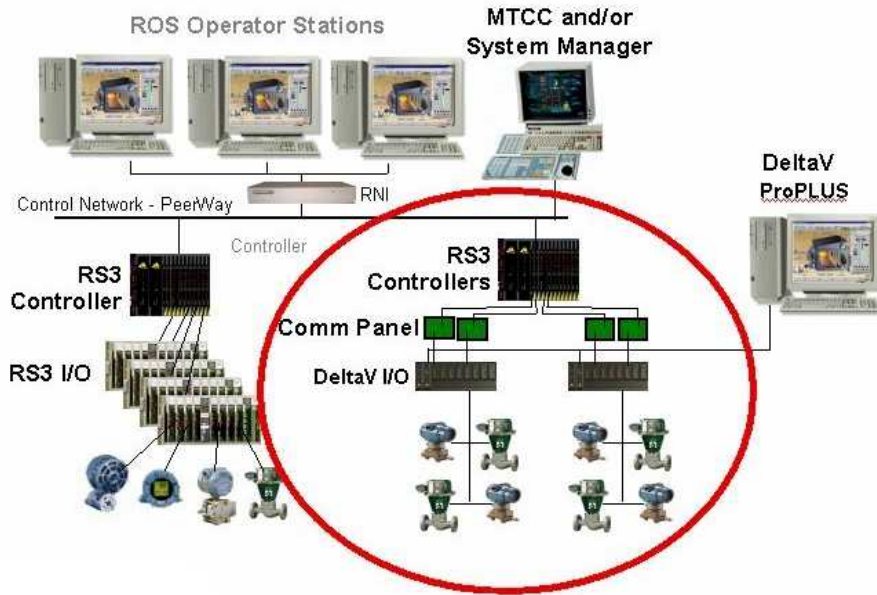



3 DOWNLOADING THE FIRMWARE

The driver software comprises 15 files, distributed on a CD. These files must be copied to the DeltaV directory on your ProPlus Workstation. The path is:

\\DeltaV\ctl\ProgSerial\S2-RS3

The following shows a completed copy operation:

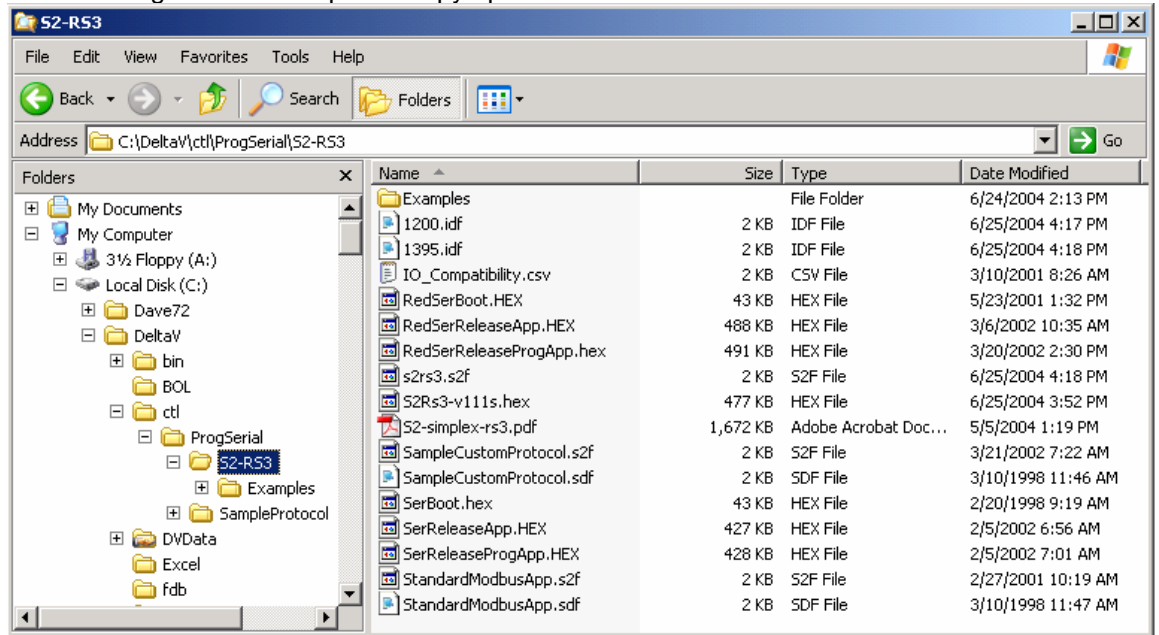

After copy completion, you are ready to program (or upgrade) the Programmable Serial Card with the supplied custom driver software. The steps are as follows:

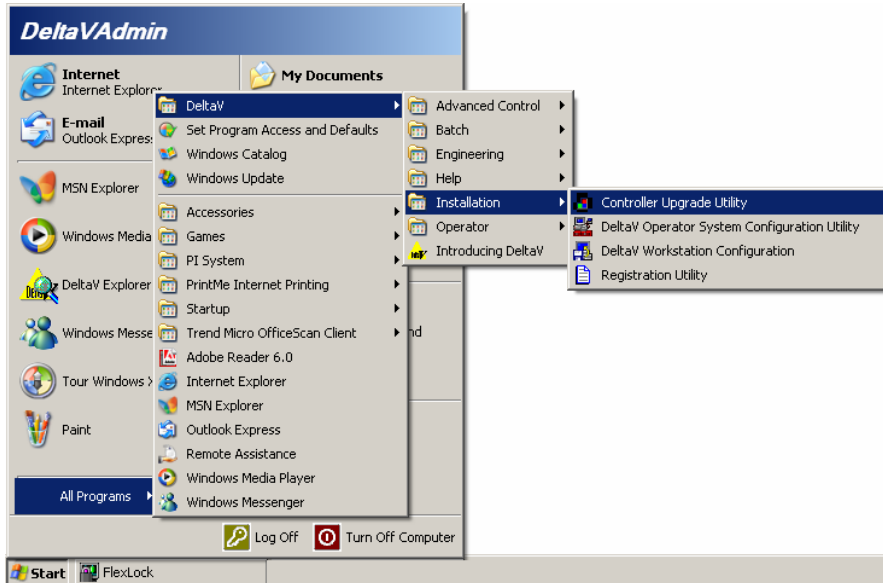

1. Click on the Start button and select DeltaV-> Installation-> Controller Upgrade Utility as shown above, and the following dialog will appear:

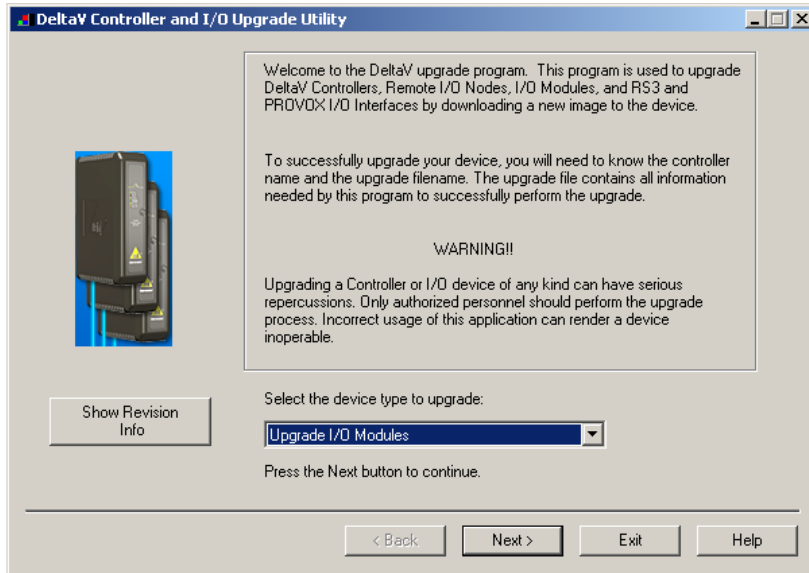

2. Select the Upgrade I/O Modules option as shown, and then click Next. The following dialog will appear, listing all the available Controllers in your network.

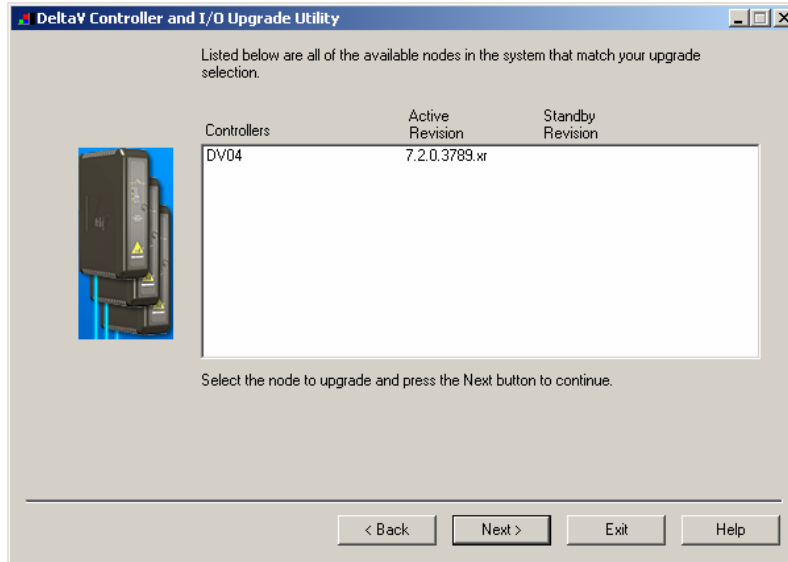



3. From this dialog, select the appropriate Controller and then Click Next. The dialog with all configured I/O modules will appear as shown below. Your list will be different.

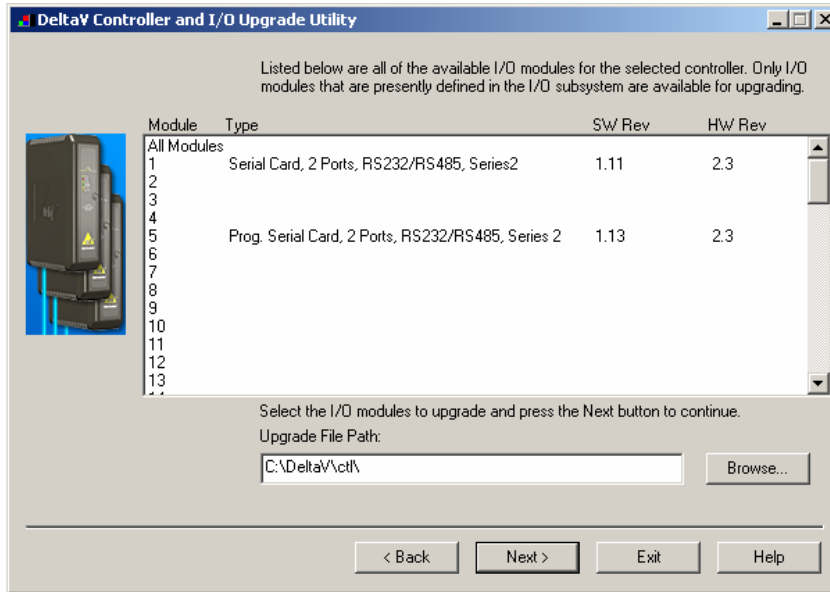

Note: The first time a standard Serial card is upgraded to the Virtual RS3 I/O, the dialog will be as shown above. When upgrading an existing Programmable Serial Card, skip Steps 4 and 5, and go to Step 6.

4. Click the Browse button and select the DeltaV path as shown below. Note that the disk drive could be C or D.

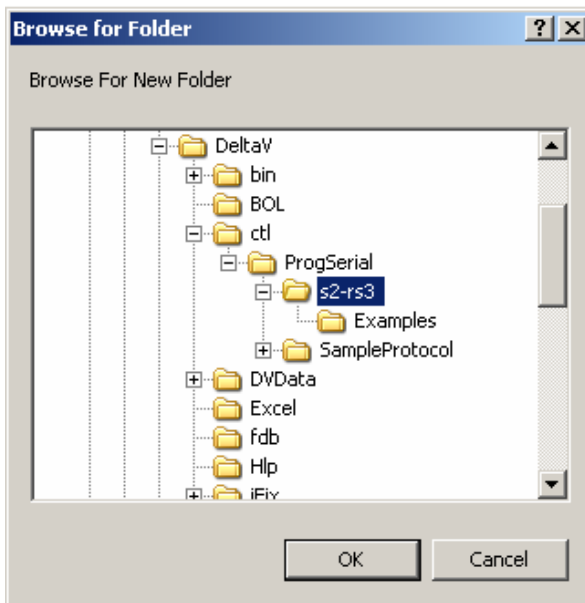

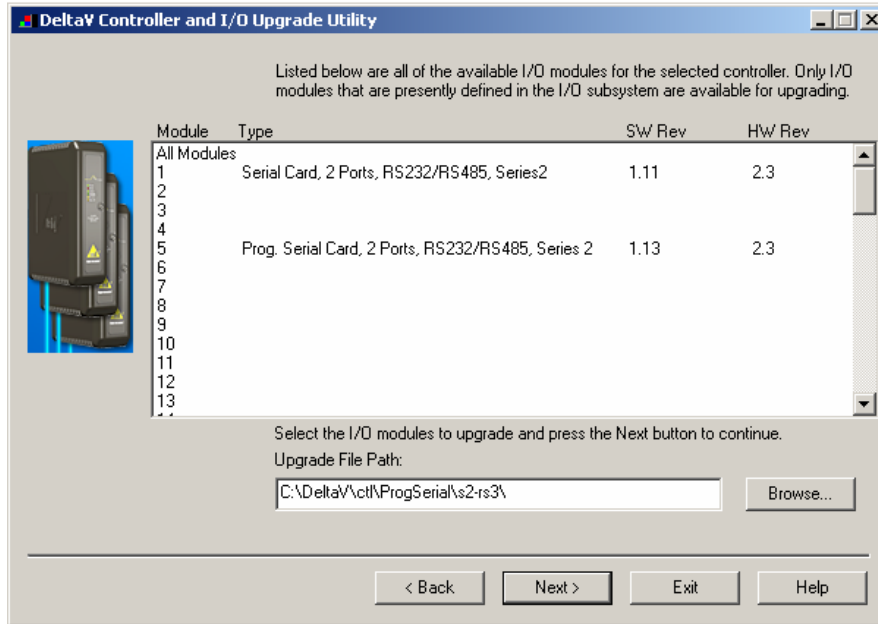

5. Select the Serial module and then click Next. Go to Step 8.

6. If you are upgrading an existing Programmable Serial Card, the dialog will be as shown below. From this dialog, select the Programmable Serial Card I/O Module in the list.

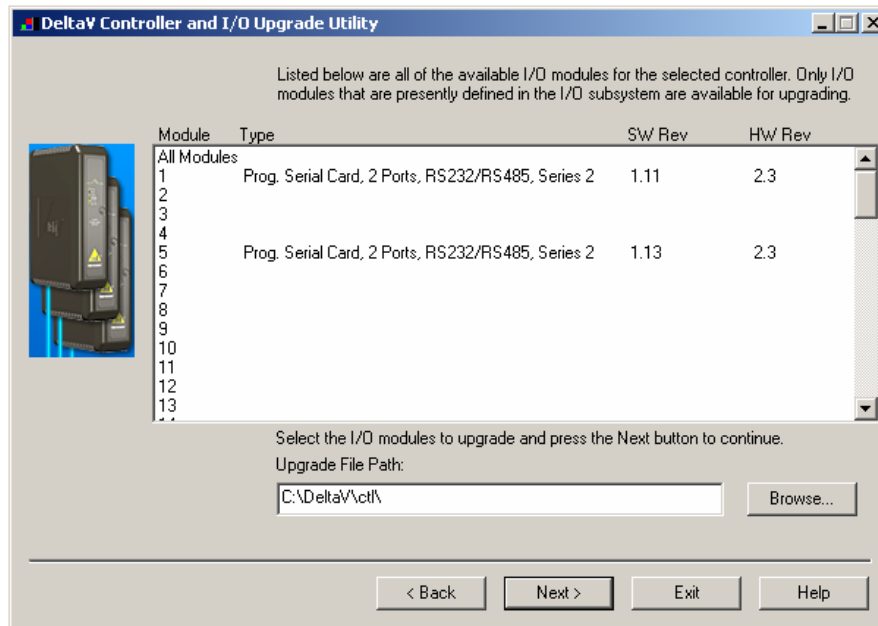

For example, we will select I/O Module 1. This will give you a dialog, from which you will select the file path to where the driver software is located. This path will be:

\\Delta\Vct\ProgSerial\S2-RS3



Once you are in the specified directory, you will need to select the following file:

S2RS3.S2F

This is shown in the following dialog.

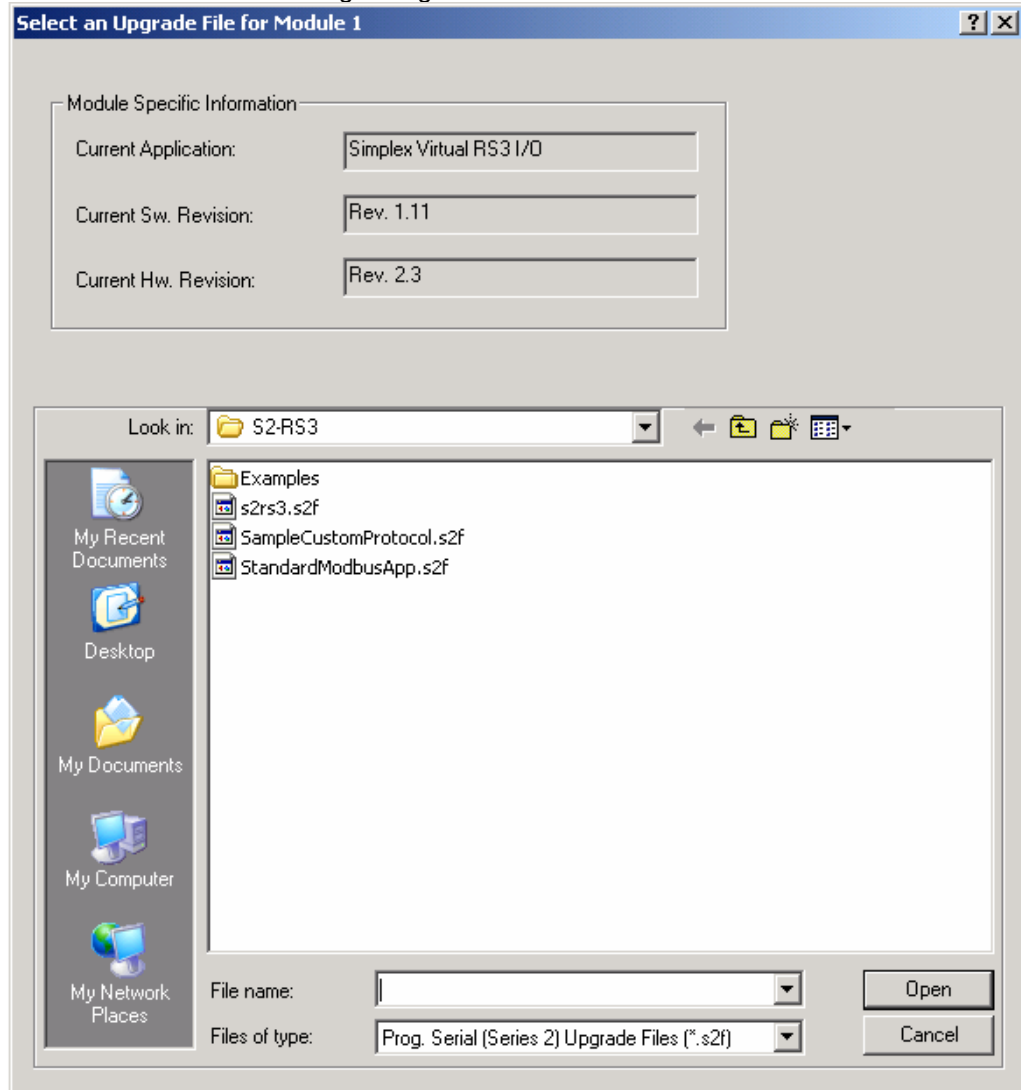

7. After selecting the .S2F file, Click on Open. This dialog will close and you will be back to the following:

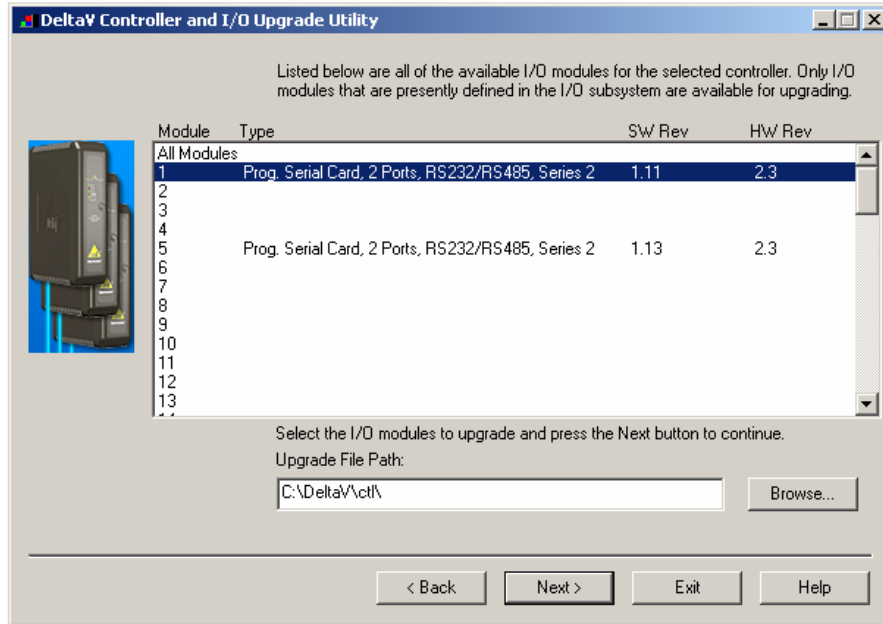

8. In this dialog, click Next again. You will get the following dialog, confirming the Controller and I/O Module to program.

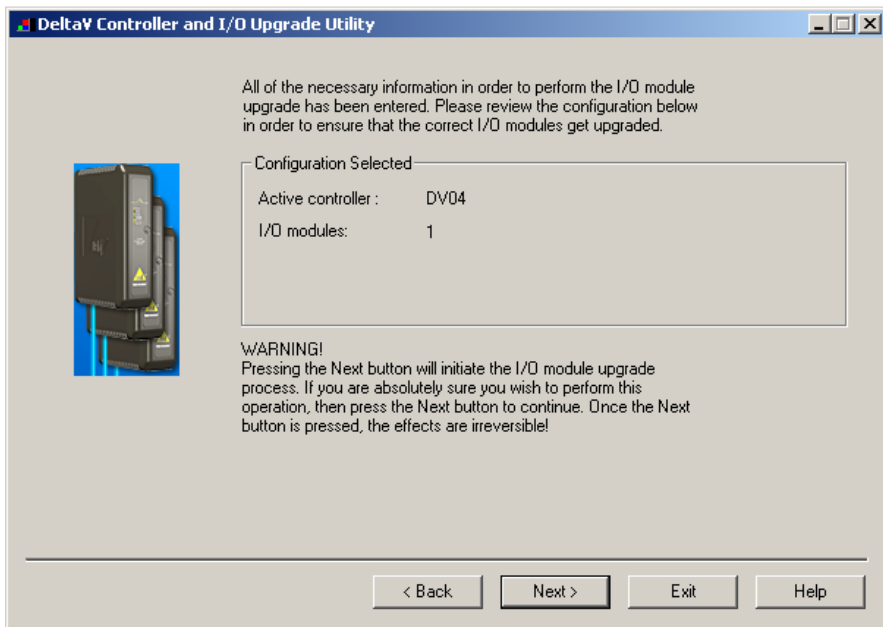



9. Click Next and the I/O Module upgrade process will begin. After completion, you will receive the following dialog, indicating success.

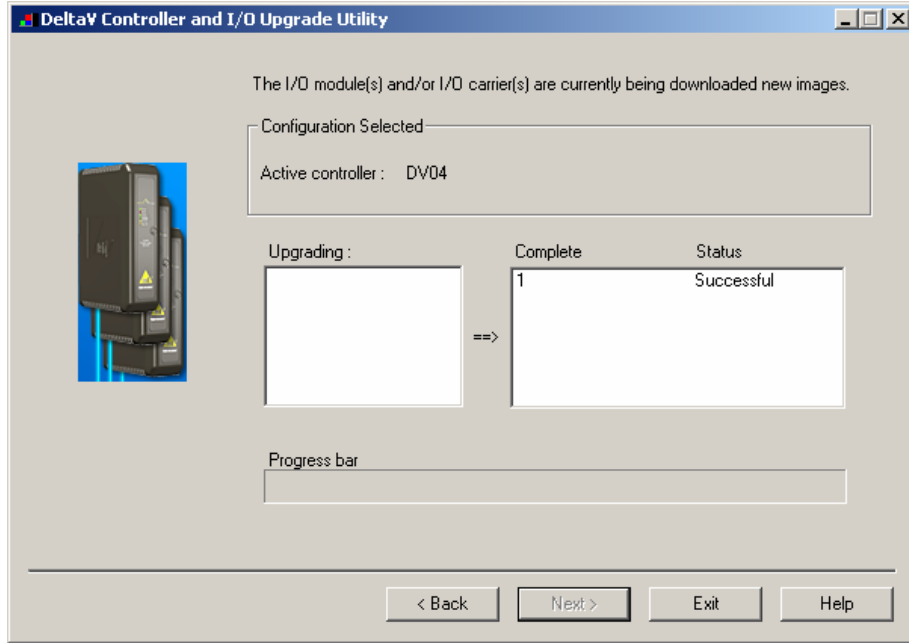

10. This completes the I/O Module upgrade process.



4 CONFIGURATION INFORMATION

This section describes the steps necessary to configure the DeltaV PSIC to obtain proper communication.

Each Serial Card in the I/O subsystem contains two channels or ports. Each port will be enabled or disabled individually and each port will contain some port specific configuration parameters. These are defined below. The configuration parameters will determine what type of FIM devices are being emulated by the PSIC.

For this application, a fixed configuration format is used. The DeltaV Explorer view of a configuration containing a Serial Card will be as follows, where C01 has a card type of Programmable Serial Card, P01 and P02 are the ports on the card, DEVXX are the FIM devices attached to the ports and DS01 to DS04 are configured datasets for each device. Card C01 can be configured as simplex, or as a redundant pair occupying 2 adjacent slots.

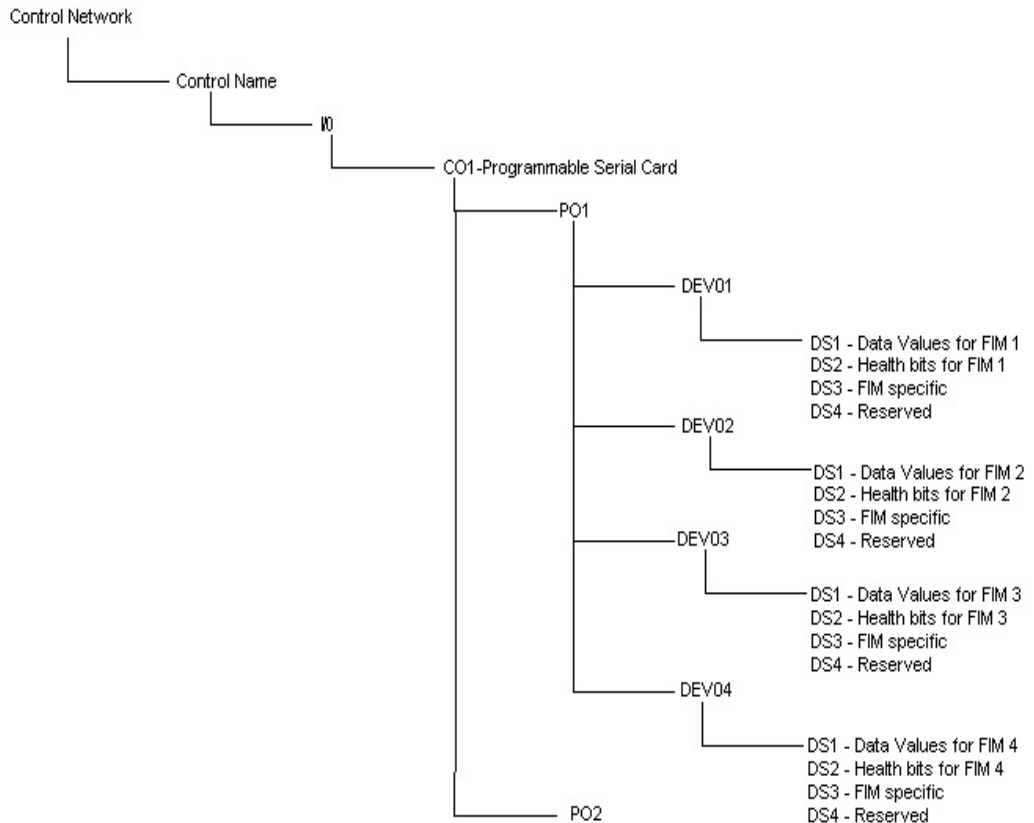

Specifically, each port PXX will be configured with up to 4 devices DEV01, DEV02, DEV03, and DEV04. Each device will be configured with four datasets DS01 to DS04. DS01 will always contain I/O data sent/received to/from RS3. DS02 contains the health bits for the FIM. DS03 and DS04 contain internal FIM specific data or are reserved for future functionality enhancements.

The above described Port, Device and Dataset configuration is a fixed structure. Recall that each port has 16 datasets. This structure simply allocates 4 datasets for each Device,

regardless of whether a FIM will be configured there or not. Consequently, DS1 of DEV01 is the 1st dataset for the Port. Likewise DS1 of DEV03 is the 9th dataset for the Port. To actually have a FIM respond at any Device location, configure FIM type into Special Data 1 of DS1 for that Device. Configure Special Data 1 as 0 for an unused FIM.

The following sections detail Port, Device and Dataset parameters.

4.1 Port Configuration

Specify the Port type. The Port type will be RS-422/485 Half Duplex for RS3. The Baud Rate, Parity, Data bits and Stop bits parameters must match RS3 Controller settings. These are 8 bits, no parity and 1 stop bit. Configure the RS3 Controller to communicate Industry Standard Baud rate (9600) or Rosemount (10.4K) as shown below in Table 1. **The minimum supported RS3 scan time by the Controller (under Control File Status) is 1 second.**

Table 1

RS3 Configured Baud Rate	PSIC Configured Baud Rate
Industry Standard – 9600	9600
Rosemount 10.4K	19200

No other Baud rates are supported, Note that when using 10.4K Baud, configure the PSIC port for 19200. The driver has been internally programmed to use 10.4K when 19200 Baud is configured.

4.2 Device Configuration

Specify four devices, one for each of 4 FIMs. The driver does not use the device address. It can simply be specified as 1, 2, 3, and 4. Under each device, specify 4 datasets. The first dataset under each device determines the FIM type to be emulated and contains the I/O values for the FIM. This is described below in Section 4.3. The second dataset contains the Health bits for the FIM. The remaining 2 datasets are FIM specific and are described in Section 4.4.

Note: All 4 Devices along with their 4 datasets must be configured even if there is not going to be a FIM at that location.

4.3 Dataset 1 Configuration

This dataset contains the field values for the FIM.

4.3.1 Data Direction:

In Simplex mode, the Data Direction is not available.

In Redundant mode, configure the Data Direction as Output for all datasets

4.3.2 Output Mode:

Two output modes are available in the DeltaV PSIC: block output (0) and single output (1). The driver does not use this value. Leave this value at its default setting.

4.3.3 DeltaV Data Type:

The type of RS3 FIM being emulated will determine the Dataset 1 Data Type. This is described in the following table:

Table 2

FIM Type	Dataset 1 Register Type
Multi Channel Discrete I/O	Boolean with status
All Multi Channel Analog Input	Floating point with status
Multi Channel Analog Output	Floating point with status

4.3.4 DeviceDataType

This value is identical to Special Data 1 value defined in Section 4.3.6, and is used only for DeltaV Diagnostics. You can leave this value as 0 (default), or configure it to be the same as Special Data 1. Configure the value as 1 for FIM-MAI, 2 for FIM-MAO, and 3 for FIM-DIO.

4.3.5 Data Start Address and Number of Values

The Start Address for each dataset must be unique. Furthermore, it is user defined.

As an example, one method, which can be used, is to represent the Start Address as follows:

DSRR

where the address components are:

- D is the device number (1-4)
- S is the dataset number (1 or 2)
- RR is the register number within the dataset

For example, using this addressing scheme, the following values for the dataset data start address and number of values can be configured:



Table 3

Device	Dataset	Start Address	Register
1	1	1100	R1100
1	2	1200	R1200
2	1	2100	R2100
2	2	2200	R2200
3	1	3100	R3100
4	2	4200	R4200

RR should always be 00 when specifying Start Address. However, when referencing a register, e.g., Registers 8 and 15, the 00 should be replaced with 08, and 15, respectively.

The FIM type, as described below, determines the number of values in a dataset:

Table 4

FIM Type	# of Values
FIM-DIO 32 Channel DIO	32
FIM-MAI 16 Channel AI	16
FIM-MAO 16 Channel AO	16

4.3.6 Special Data 1-5

Under the Special data tab, 4 values can be specified as described below:

Table 5

Special Data	Value and Usage
1	<p>0 - No emulated FIM configured or a real RS3 FIM occupies the slot. 1 - This will configure an emulated 16 Channel FIM-MAI in this slot 2 - This will configure an emulated 16 Channel FIM-MAO in this slot 3 - This will configure an emulated 32 Channel FIM-DIO in this slot</p>
2	<p>This value is the Output Mask for FIM-DIO channels 1-16. The output mask is a 16-bit value, where a bit is 1 if the corresponding channel is a DO, or 0 if the corresponding channel is a DI. For example, if channel 1 and 2 are DO, the mask is 3. Channels 17-32 are always DI.</p> <p>RS3 writes this value to the PSIC, and it is stored in Dataset 3 Register 1 of this FIM when communications are online. The user-configured value in this special data register must match the value reported by RS3.</p> <p>Note: This register is used only if Special Data 1 has a configured value of 3 (FIM-DIO). It is optional when the PSIC is in simplex mode, and required for redundant mode.</p>
3	<p>This value is the Failsafe Mask for FIM-MAO and FIM-DIO channels 1-16. The output mask is a 16-bit value, where a bit is 1 if the corresponding output channel is held in its current state in case of a communications failure.</p> <p>RS3 writes this value to the PSIC, and it is stored in Dataset 3 Register 2 of this FIM when communications are online. The user-configured value in this special data register must match the value reported by RS3.</p> <p>Note: This register is used only if Special Data 1 has a configured value of 2 (FIM-MAO) or 3 (FIM-DIO). It is optional when the PSIC is in simplex mode, and required for redundant mode.</p>
4	<p>This value is used as a flag for FIM-DIO. If the value is 1, then the driver will perform DO feedback checking, and report a feedback check error to RS3 when the DeltaV field DO state does not match the RS3 commanded state. Note that the user must supply the current field DO state in Dataset 2, bits 51-66.</p> <p>If the value is 0, no feedback check is performed and RS3 writes to DO channels are assumed to be successful.</p> <p>Note: This register is used only if Special Data 1 has a configured value of 3 (FIM-DIO). It is used in both simplex and redundant modes.</p>
5	Not used

4.4 Dataset 2 Configuration

This dataset contains the health status values for the FIM.

4.4.1 Data Direction:

In Simplex mode, the Data Direction is not available.

In Redundant mode, configure the Data Direction as Output for all datasets

4.4.2 Output Mode:

Two output modes are available in the DeltaV PSIC: block output (0) and single output (1). The driver does not use this value. Leave this value at its default setting.

4.4.3 DeltaV Data Type:

For dataset 2, the Data Type will always be Boolean with Status.

4.4.4 DeviceDataType

The driver does not use this value. You can leave this value as 0 (default).

4.4.5 Data Start Address and Number of Values

The Start Address for dataset 2 should follow the same pattern as described above for dataset 1. The number of values will be 40 for FIM_MAO and FIM_MAI. For FIM-DIO, the number of values is 66. The health bit mapping is as follows:

Table 6

FIM Type	Description
FIM-DIO	<p>Bits 1-32 - Each bit represents the health of the corresponding field value.</p> <p>Bit 33 - overall test bit Bit 34 - A/D #1 Bit 35 - A/D #2 Bit 36 - A/D #3 Bit 37 - A/D #4 Bit 38 - Configuration data Bit 39 - disconnect bit Bit 40 - Health of other card</p> <p>Note: In general, you do not need to use bits 33-40. Bits 1-40 are maintained for compatibility with previous versions of the driver.</p> <p>Unlike previous versions, the current driver allows you to generate DO feedback check errors back to RS3. Bits 51-66 are used for this purpose. To generate feedback check errors, do the following:</p> <ol style="list-style-type: none"> 1. Set special data 4 of dataset 1 to 1. 2. Wire the current state of DeltaV DO channels 1-16 to bits 51-66 of this dataset, respectively. Skip any channels that are configured as DI. For example, channel 1 is wired to bit 51, and channel 16 is wired to channel 66.
FIM-MAI FIM-MAO	<p>Bits 1-16 – Each bit represents the health of the corresponding field value. Bits 17-32 – not used.</p> <p>Bit 33 - loop power module presence Bit 34 - loop power module health Bit 35 - loop power module status Bit 36 - primary power status Bit 37 - ground fault Bit 38 - overall health Bit 39 - disconnect bit Bit 40 - Health of other card</p> <p>Note: In general, you do not need to use bits 33-40.</p>



4.4.6 Special Data 1-5

Special data values are not used for datasets 2, 3 and 4.

4.5 Dataset 3 Configuration

This dataset is used only for FIM-DIO emulation and contains internal DIO configuration and run-time values. For all other FIM types, the dataset is reserved for future use.

4.5.1 Data Direction:

In Simplex mode, the Data Direction is not available.

In Redundant mode, configure the Data Direction as Output for all datasets

4.5.2 Output Mode:

Two output modes are available in the DeltaV PSIC: block output (0) and single output (1). The driver does not use this value. Leave this value at its default setting.

4.5.3 DeltaV Data Type:

For dataset 3, the Data Type will always be 16 bit unsigned integer with Status.

4.5.4 DeviceDataType

The driver does not use this value. You can leave this value as 0 (default).

4.5.5 Data Start Address and Number of Values

The Start Address for dataset 3 should follow the same pattern as described above for dataset 1.



The FIM type, as described below, determines the number of values in a dataset:

Table 7

FIM Type	# of Values
FIM-DIO 32 Channel DIO	16 Register 1 is Output Mask. Register 2 is Failsafe Mask. Note 1. The Output Mask is configuration information received from RS3. It represents a bit mask (16 bits) indicating which of the first 16 channels are configured as DO. For example, a value of 65535 configures all 16 channels to be DO. A value of 255 configures the first 8 channels to be DO, while channels 9-16 are DI. Note that channels 17-32 are always DI. Note 2. The Failsafe Mask is configuration information received from RS3. It represents a bit mask (16 bits) indicating which DO channels are held in their current state, and which are set to 0 in case of a communication failure. A bit value of 1 indicates Hold.
FIM-MAI 16 Channel AI	16
FIM-MAO 16 Channel AO	16 Register 2 is Failsafe Mask. Note 3. The Failsafe Mask is configuration information received from RS3. It represents a bit mask (16 bits) indicating which AO channels are held in their current state, and which are set to 0 in case of a communication failure. A bit value of 1 indicates Hold.

4.5.6 Special Data 1-5

Special data values are not used for datasets 2, 3 and 4.

4.6 Serial Driver Communications

The driver will continuously communicate with the RS3 Controllers. Commands are received from RS3 and responses are sent back. The Serial Card does not initiate any communications. Output data is received from RS3 and placed in Serial Card registers. Input data already contained in the Serial Card registers is sent back to RS3. Any communication errors are reported back to DeltaV via standard status reporting



5 Operational Check

5.1 Scope

The following sections provide some assistance to ensure the interface is working properly.

5.2 Verify Hardware and Software Version Number

The user can verify that the Virtual RS3 I/O driver has been installed using the DeltaV Diagnostics tool. The Diagnostics tool will show the Hardware Revision No. (HwRev) and the Software Revision No. (SwRev).

To begin the DeltaV Diagnostic tool select Start-> DeltaV-> Operator-> Diagnostics. In the Diagnostics tool expand the Controller, I/O and then double click on the Programmable Serial Interface Card that has the driver installed.

The following information will be displayed:

:	:	:
HwRev	Hardware Revision	1.1 (or later)
SwRev	Software Revision	P1.0 (or later)

5.3 Verify Configuration

- Verify port configuration: The serial port must be enabled. User needs to make sure communication settings such as baud rate, parity, and number of data bits match the RS3 Controller settings.
- Verify dataset configuration: The datasets configured must be as shown above.

5.4 Verify I/O Communication With Control Studio

User can create I/O modules in the control studio to verify correct values are read from the PSIC. For AO and DO data, the values should be changed in the RS3 Controller and verified that the new data are correctly reported. Similarly, verify that the AI and DI data is being read correctly from DeltaV and written to PSIC registers.

5.5 Using Diagnostics

- Verify PSIC communication: Select the PSIC on Diagnostics and press the right mouse button. Select Display Real -Time Statistics from the drop down menu. If the Programmable Serial Interface Card is functioning then the user will see the Valid Responses counter and the Async and/or Sync Transactions counters incrementing. There will not be any error counting up.



- Verify port statistics: Select the Port on the Programmable Serial Interface Card and press the right mouse button. Then select Display Port Statistics from the drop down menu. Verify that the port communications statistics are being displayed properly and are counting as expected for the RS3 protocol's functionality.
- Verify dataset values: Select a dataset and press the right mouse button. Select View Dataset Registers from the Drop down window. Verify that the dataset values are displayed as expected.

5.6 LED Indication

The Yellow LED for the port should be on solid when all communications on that port are valid. The Yellow LED should be blinking if there is some valid communications and some communications with errors on that port. The Yellow LED should be OFF if there are no valid communications on that port.



6 DeltaV–RS3 Electrical Interface

The electrical interface between DeltaV and RS3 conforms to the RS-422/485, Half Duplex protocol.

Each PSIC has 2 ports, which function independently. The distance between the serial card and the RS3 Comm Term Panel can be as much as 4000 feet, per the RS-422/485 standard. Section 6.1 shows the pin assignments for the PSIC serial terminal block for RS-422/485 Half Duplex protocol.

6.1 RS-422/485 Pin Assignments for DeltaV PSIC

Terminal Number	Signal Description
1	Port 1 - Isolated Ground (GND)
2	Port 1 - Data +
3	Unused
4	Port 1 - Data -
5	Unused
6	Unused
7	Unused
8	Unused
9	Port 2 - Isolated Ground (GND)
10	Port 2 - Data +
11	Unused
12	Port 2 - Data -
13	Unused
14	Unused
15	Unused
16	Unused

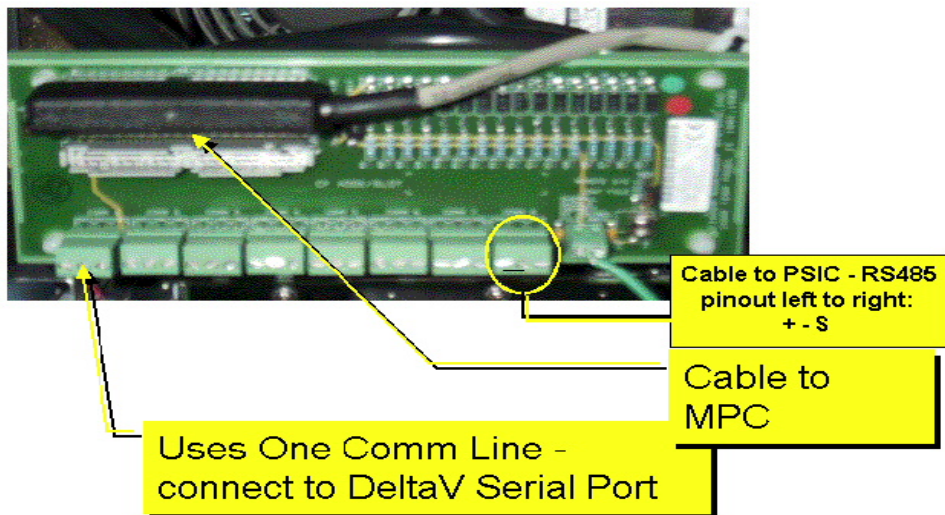



Simplex Wiring

Simplex wiring between the serial cards termination block and the Comm. Term Panel (CTP) uses a single twisted pair with shield. Connect the shield pin in the CTP, to the ground screw terminal in the serial card termination block. Connect the Data+ and Data- from the CTP to the termination block, respectively.

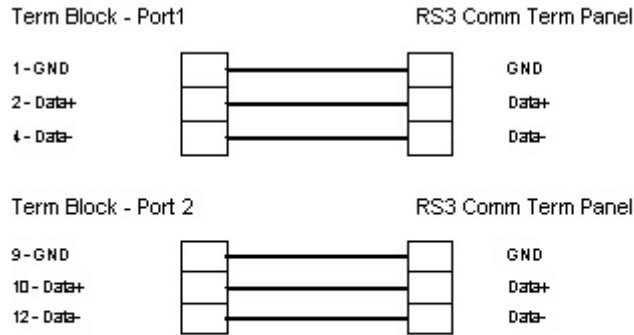



M Y N A H

Powerful Solutions for Digital Plants

7 Technical Support

For technical support or to report a defect, please give MYNAH Technologies a call at (636) 681-1555. If a defect is discovered, please document it in as much detail as possible and then fax your report to us at (636) 681-1660.

For Product functionality questions, ask for the people in the following order:

1. Nobin William
2. Martin Berutti

For Commercial issues, ask for people in the following order:

1. Martin Berutti
2. Jane Wagner

For all other driver and related questions, ask for Nobin William.

You can also send us your questions via e-mail. Our addresses are:
support@mynah.com

Thank you for using DeltaV.



8 Example

8.1 Configuration for 4 FIMS

In this configuration, Card 1 is added, and 4 FIMS are defined under Port 1. The FIMS are as follows:

Table 8

Device #	FIM Type
1	FIM-MAI
2	FIM-MAI
3	FIM-MAO
4	FIM-DIO

Step 1:

In the DeltaV Explorer, Right Mouse Click on the I/O entry and select New Card. The following dialog will appear. In this dialog, select Slot Position. In this example, we selected position 01. Click OK to continue. This will add a simplex programmable serial card. To enable redundancy, select the Card is redundant check box. The redundant serial card will occupy two adjacent slots as an odd-even pair.

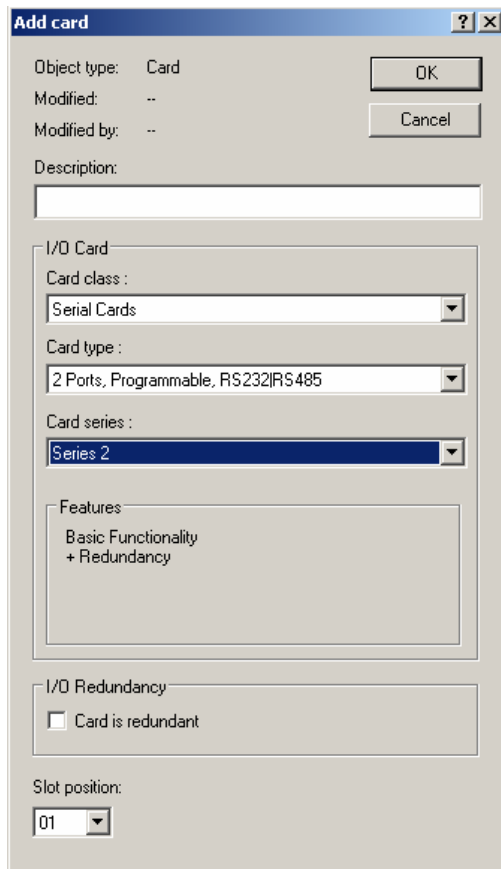



Step 2:

The new card will be added with 2 ports, P01 and P02. Next, Right Mouse Click on port P01, and select Properties as follows:

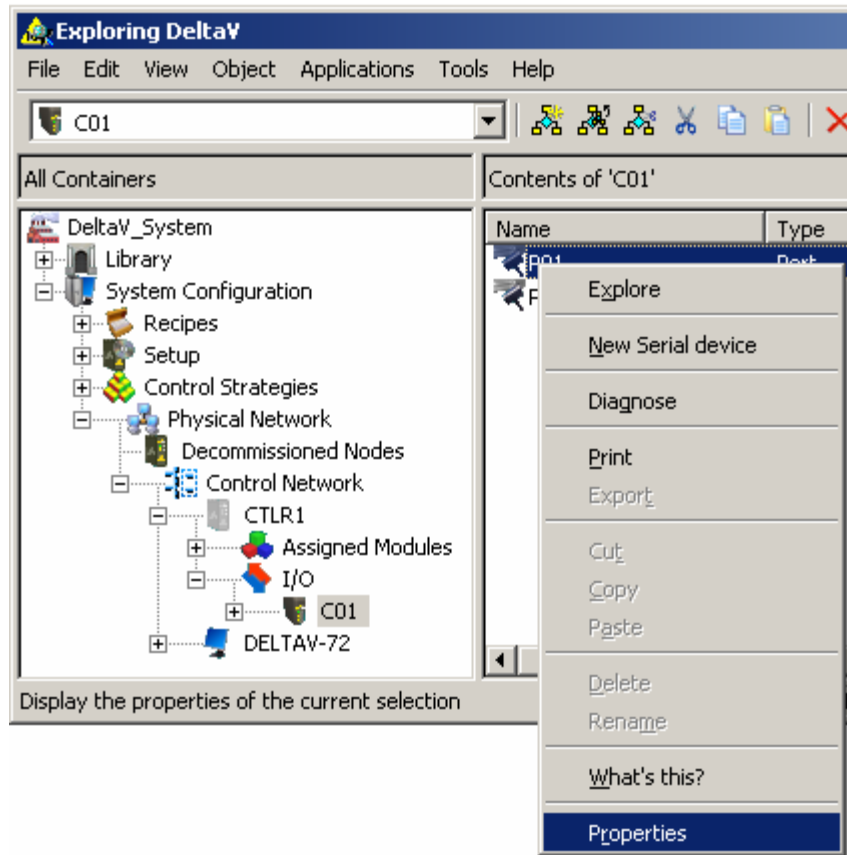

When Properties are selected, the following dialog will appear, allowing you to configure the port. Configure the values as shown.

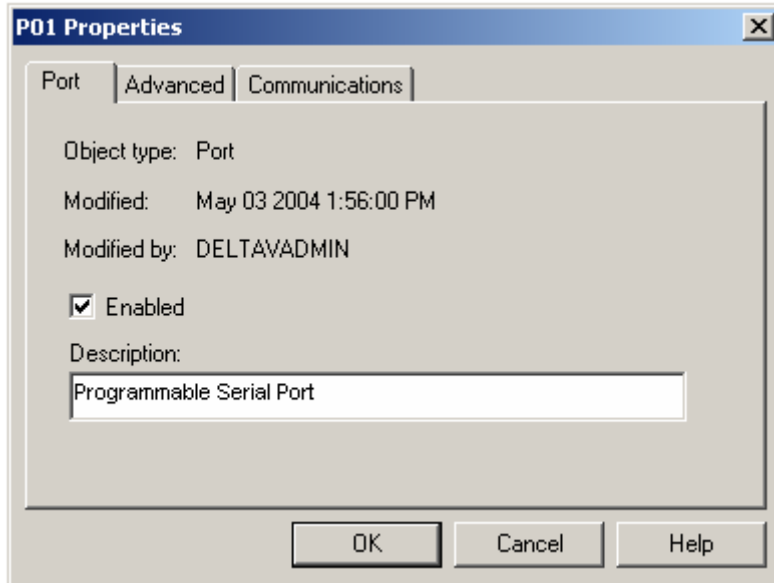

Click the Advanced tab.

If the driver is to run in Simplex mode, configure the port as Slave as shown below.

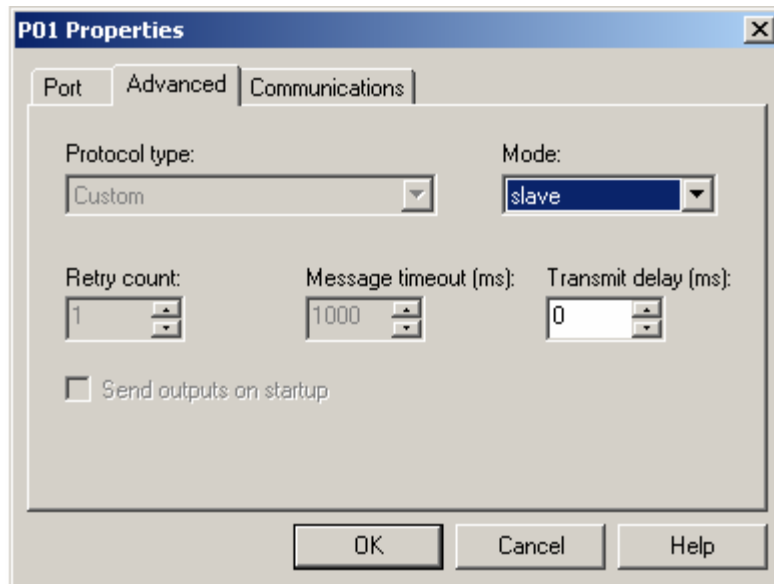



Next, click the Communications tab and configure the Baud rate as 9600 (shown below), if RS3 has been configured to communicate at the Industry Standard Baud rate.

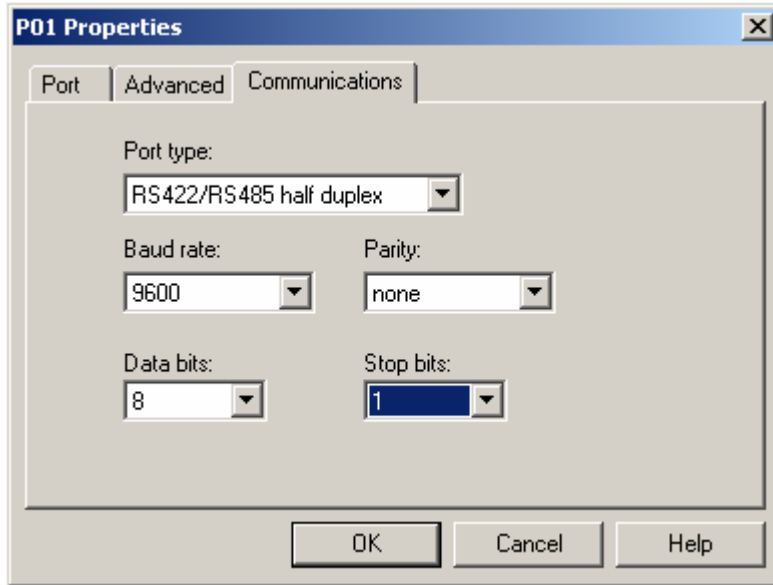

Configure the Baud rate as 19200 (shown below), if RS3 has been configured to communicate at the Rosemount Baud rate. The Virtual RS3 I/O Driver will internally convert 19200 Baud to 10.4K Baud.

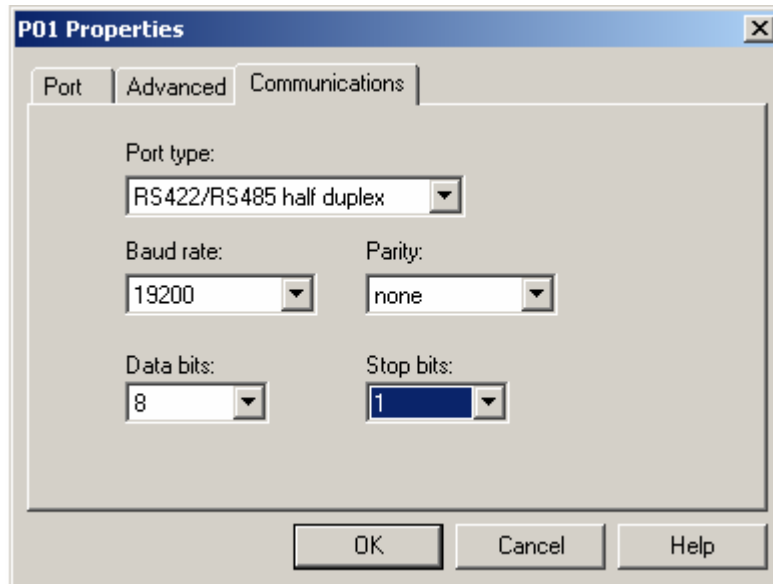

Click on OK to complete Port Configuration.



Step 3:

Add FIM devices under port P01. We will add 4 devices, addresses 1, 2, 3, and 4. Right Mouse Click on Port P01 as shown below and select New Device.

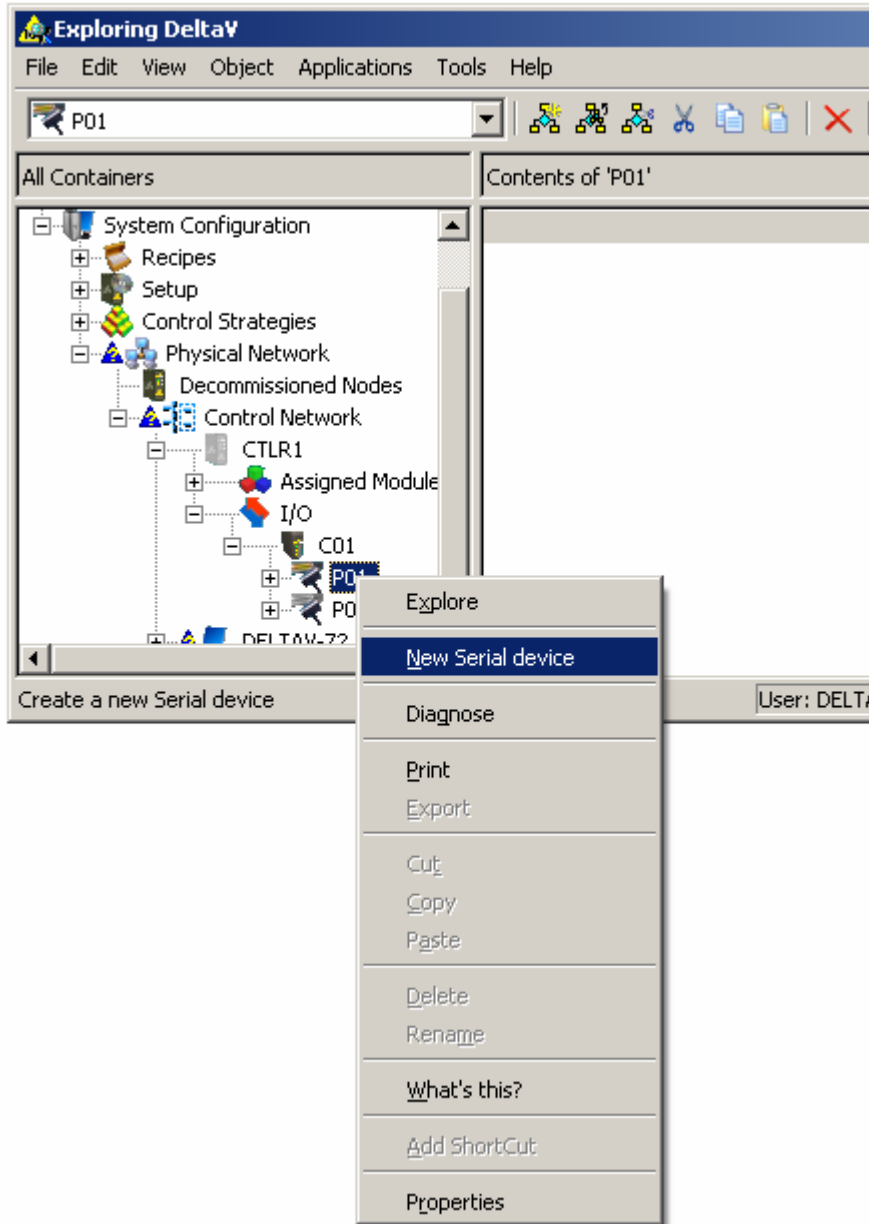

The following dialog will appear. Add description text and click OK. Create 4 devices in the same way.



Step 4:

Now we must create 4 datasets under each device. The datasets will have different configuration parameters based on the type of FIM being emulated. Dataset 1 of each device determines the type of FIM. First, Right Mouse Click on DEV01, and select New Dataset as shown below:

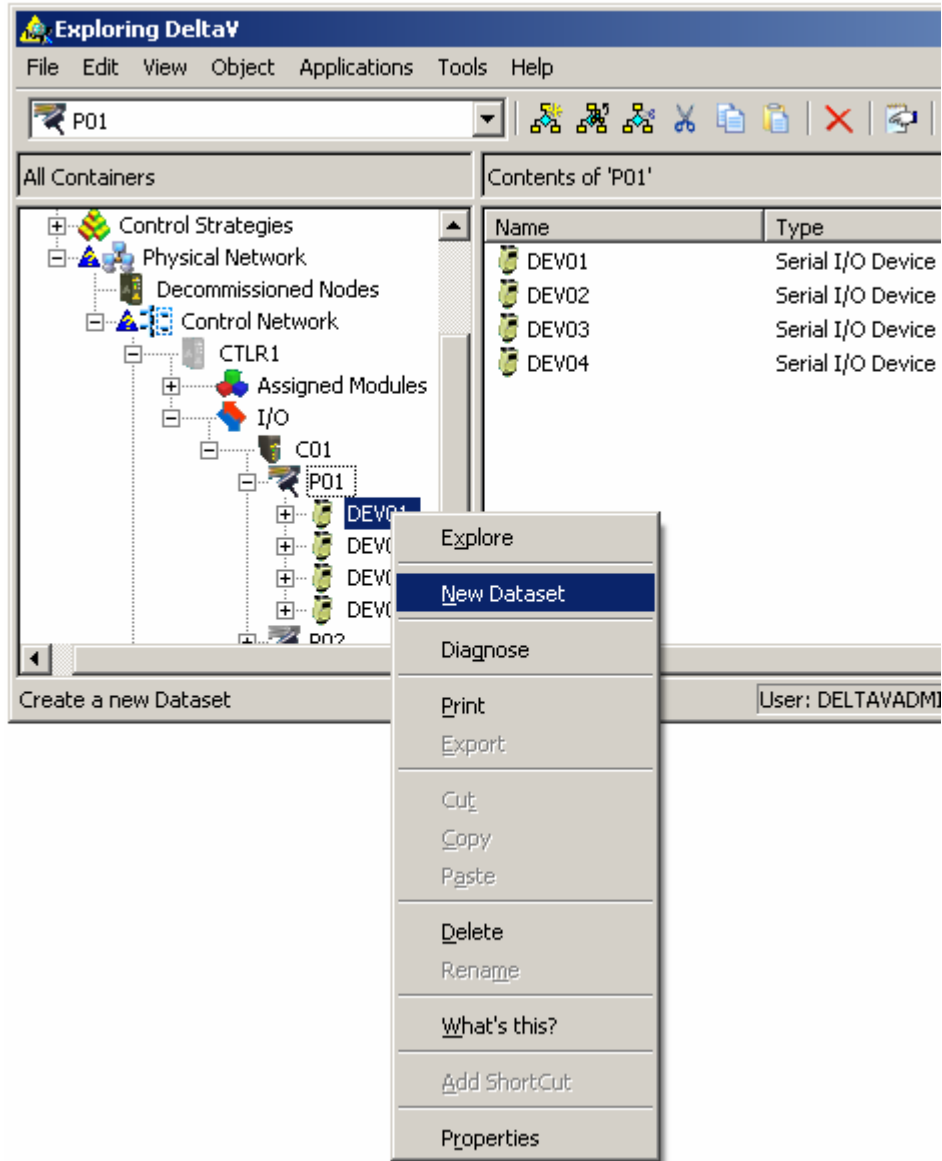

When New Dataset is selected, the following dialog will appear. Since DEV01 and DEV02 are both FIM-MAI type, their configuration will be identical in all aspects except the Register starting addresses. Configure the parameters as given in Table 9 and shown in the following dialogs:



Table 9

Device#	Dataset#	Data Type	Device Data Type	Start Address	Number of Values	Special Data
1	1	Floating Point	1	1100	16	Reg 1 = 1 All others 0
2	1	Floating Point	1	2100	16	Reg 1 = 1 All others 0

Dataset 1 dialogs:

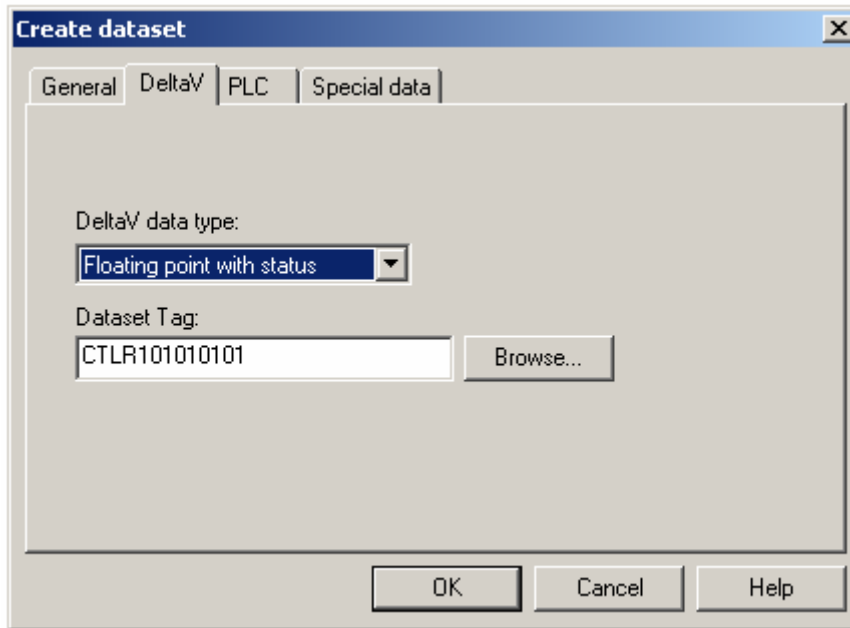



Create dataset [X]

General | DeltaV | PLC | **Special data**

Device data type:

Data start address: Number of values:

OK Cancel Help

Create dataset [X]

General | DeltaV | PLC | **Special data**

Special data 1

Special data 2

Special data 3

Special data 4

Special data 5

OK Cancel Help



Dataset 2, 3, and 4 will be configured with parameters as shown in Table 10 and the following dialogs:

Table 10

Device#	Dataset#	Data Type	Start Address	Number of Values	Special Data
1	2	Boolean	1200	40	All 0
1	3	16 bit UINT	1300	16	All 0
1	4	16 bit UINT	1400	16	All 0
2	2	Boolean	2200	40	All 0
2	3	16 bit UINT	2300	16	All 0
2	4	16 but UINT	2400	16	All 0

Dataset 2 dialogs:

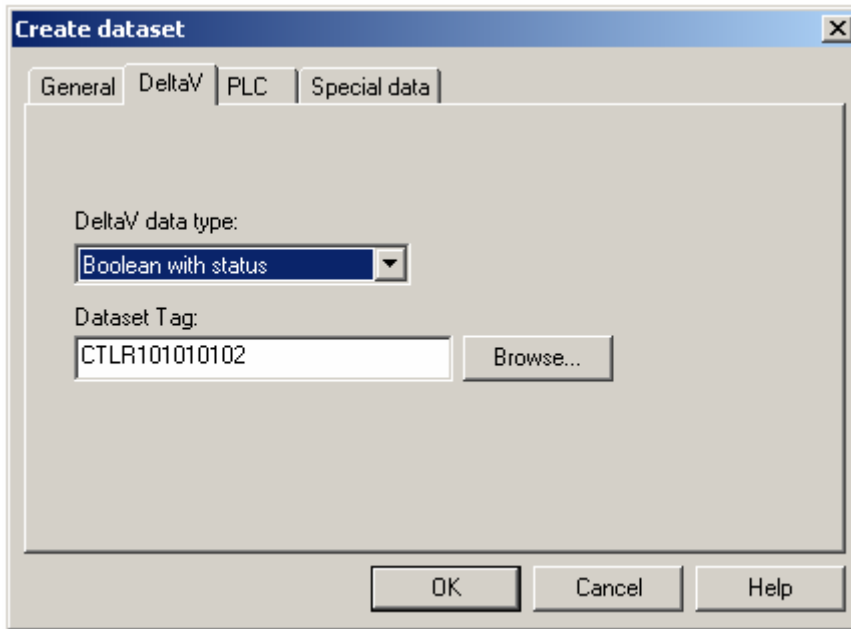



The screenshot shows the 'Create dataset' dialog box with the 'General' tab selected. The 'Device data type' is set to 0. The 'Data start address' is 1200. The 'Number of values' is 40. Buttons for 'OK', 'Cancel', and 'Help' are at the bottom.

The screenshot shows the 'Create dataset' dialog box with the 'Special data' tab selected. It contains five input fields labeled 'Special data 1' through 'Special data 5', each with the value 0. Buttons for 'OK', 'Cancel', and 'Help' are at the bottom.

Dataset 3 and 4 dialogs:

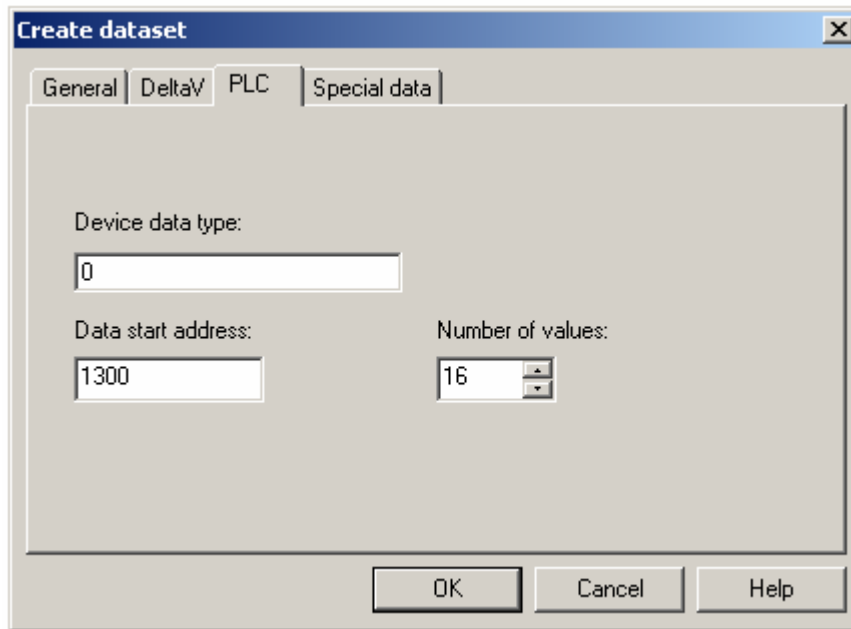
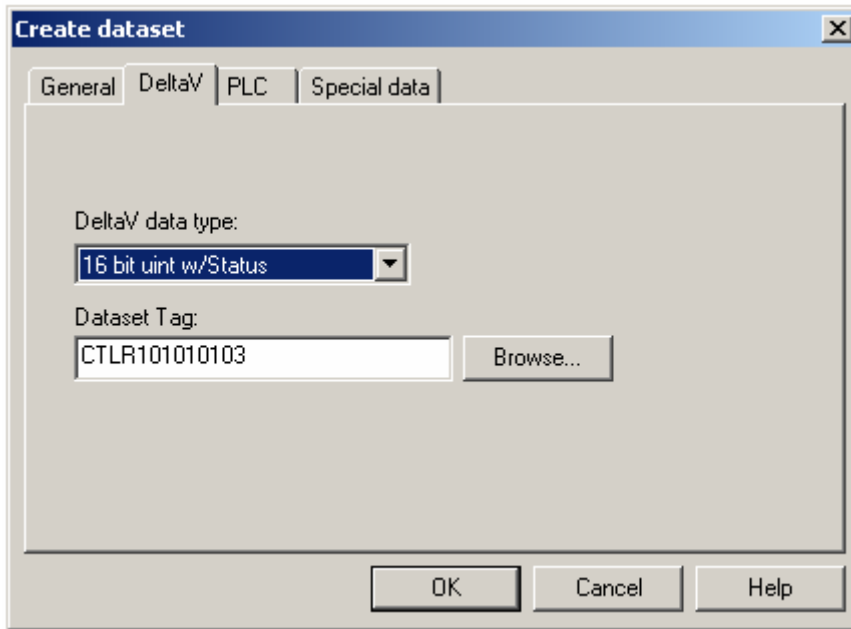



The image shows a software dialog box titled "Create dataset". It has four tabs: "General", "DeltaV", "PLC", and "Special data". The "Special data" tab is selected. Inside the dialog, there are five rows, each with a label "Special data 1" through "Special data 5" and a corresponding text input field. Each input field contains the number "0". At the bottom of the dialog, there are three buttons: "OK", "Cancel", and "Help".



Step 5:

In this step, we will create datasets for DEV03. This device will emulate a FIM-MAO. Right Mouse Click on DEV03, and select New Dataset. Configure the dataset parameters as shown in Table and dialogs below:

Table 11

Device#	Dataset#	Data Type	Device Data Type	Start Address	Number of Values	Special Data
3	1	Floating Point	2	3100	16	Reg 1 = 2 Reg 2 = 0 Reg 3 = 0 Reg 4 = 0 Reg 5 = 0

Dataset 1 dialogs:

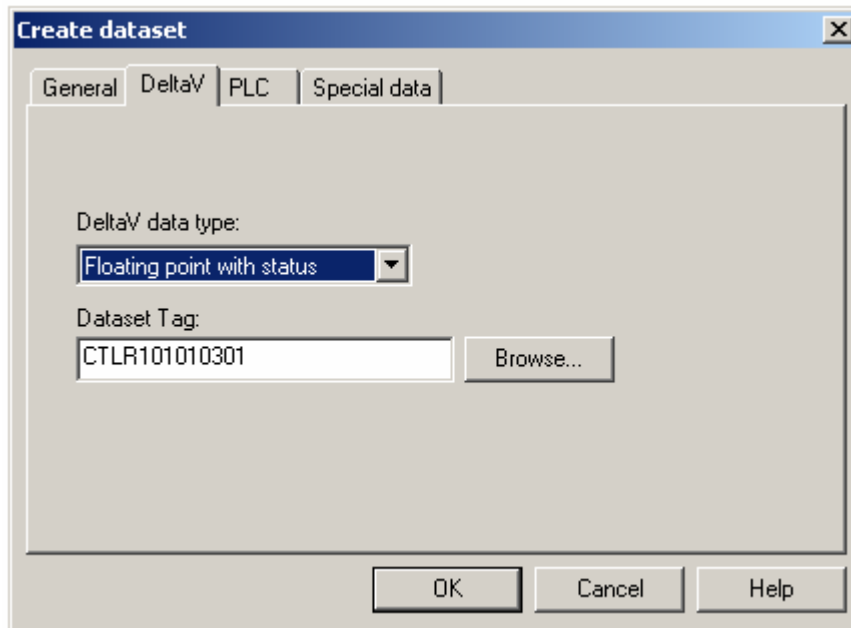



Create dataset [X]

General | DeltaV | PLC | **Special data**

Device data type:

Data start address: Number of values:

OK Cancel Help

Create dataset [X]

General | DeltaV | PLC | **Special data**

Special data 1:

Special data 2:

Special data 3:

Special data 4:

Special data 5:

OK Cancel Help



Dataset 2 dialogs:

Table 12

Device#	Dataset#	Data Type	Start Address	Number of Values	Special Data
3	2	Boolean	3200	40	All 0

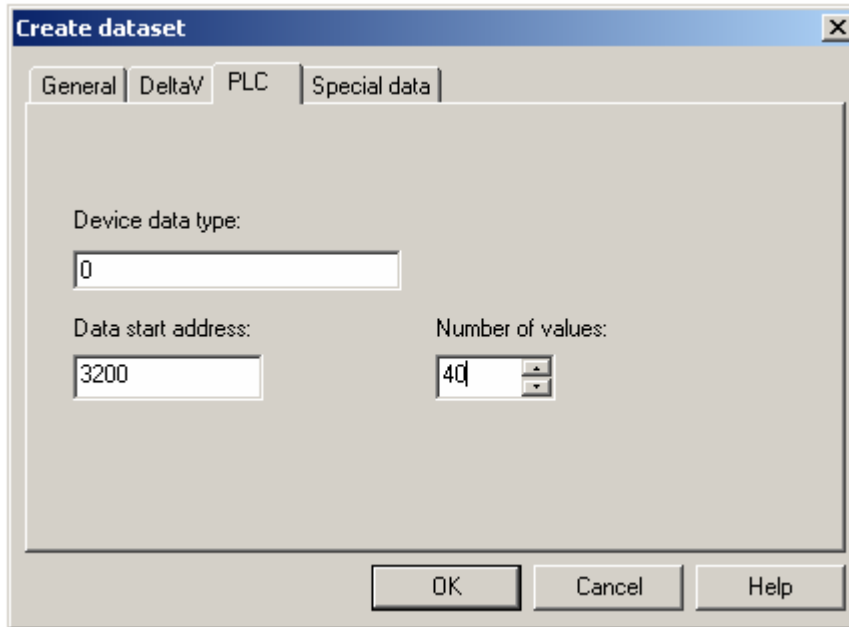
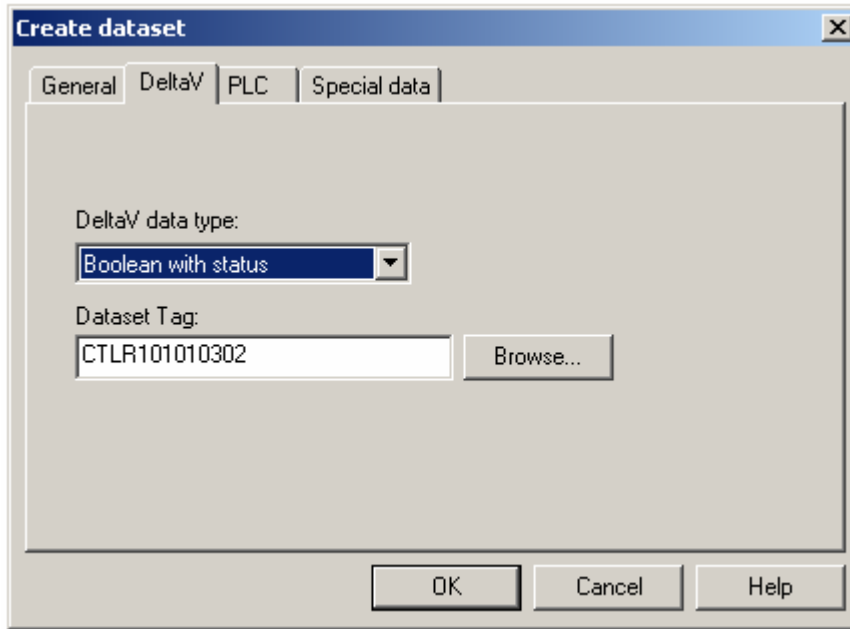

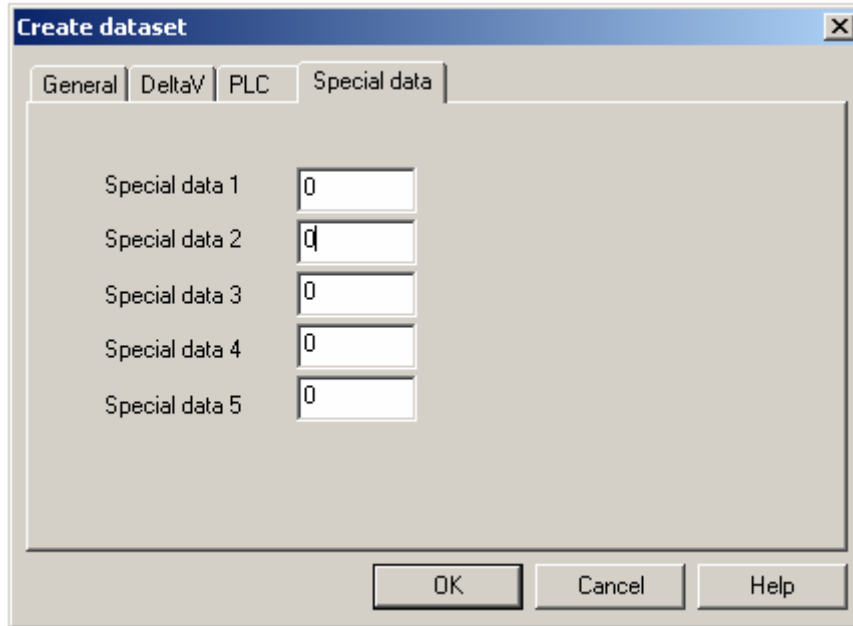

Dataset 3 and 4:

Table 13

Device#	Dataset#	Data Type	Start Address	Number of Values	Special Data
3	3	16 bit UINT	3300	16	All 0
3	4	16 bit UINT	3400	16	All 0

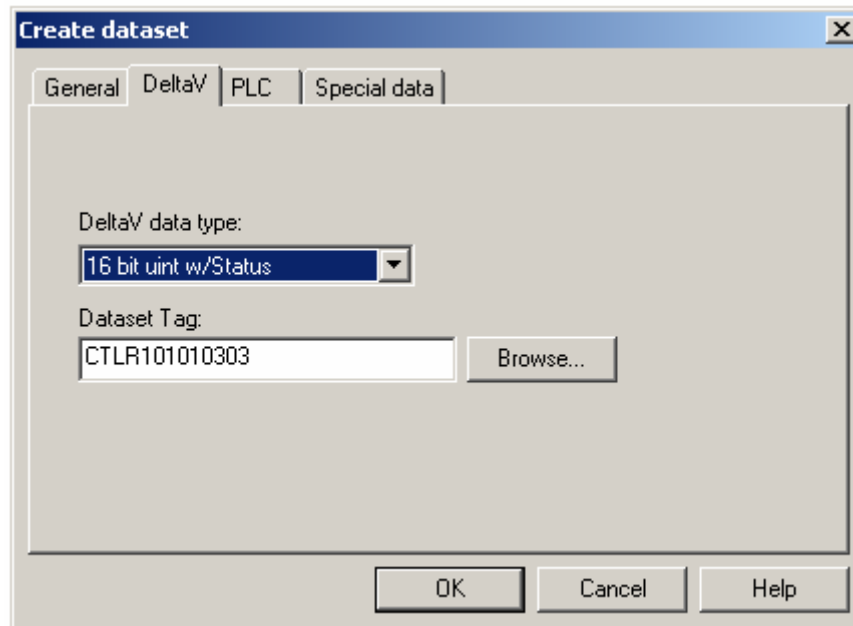



The screenshot shows the 'Create dataset' dialog box with the 'General' tab selected. The 'Device data type' is set to 0. The 'Data start address' is 3300 and the 'Number of values' is 16. Buttons for 'OK', 'Cancel', and 'Help' are at the bottom.

Device data type:	<input type="text" value="0"/>
Data start address:	<input type="text" value="3300"/>
Number of values:	<input type="text" value="16"/>

The screenshot shows the 'Create dataset' dialog box with the 'Special data' tab selected. It contains five input fields for 'Special data 1' through 'Special data 5', all containing the value 0. Buttons for 'OK', 'Cancel', and 'Help' are at the bottom.

Special data 1	<input type="text" value="0"/>
Special data 2	<input type="text" value="0"/>
Special data 3	<input type="text" value="0"/>
Special data 4	<input type="text" value="0"/>
Special data 5	<input type="text" value="0"/>



Step 6:

In this step, we will create datasets for DEV04. This device will emulate a FIM-DIO. Right Mouse Click on DEV04, and select New Dataset. Configure the dataset parameters as shown in Table and dialogs below:

Table 14

Device#	Dataset#	Data Type	Device Data Type	Start Address	Number of Values	Special Data
4	1	Boolean	3	4100	32	Reg 1 = 3 Reg 2 = 0 Reg 3 = 0 Reg 4 = 1- feedback check Reg 5 = 0

Dataset 1 dialogs:

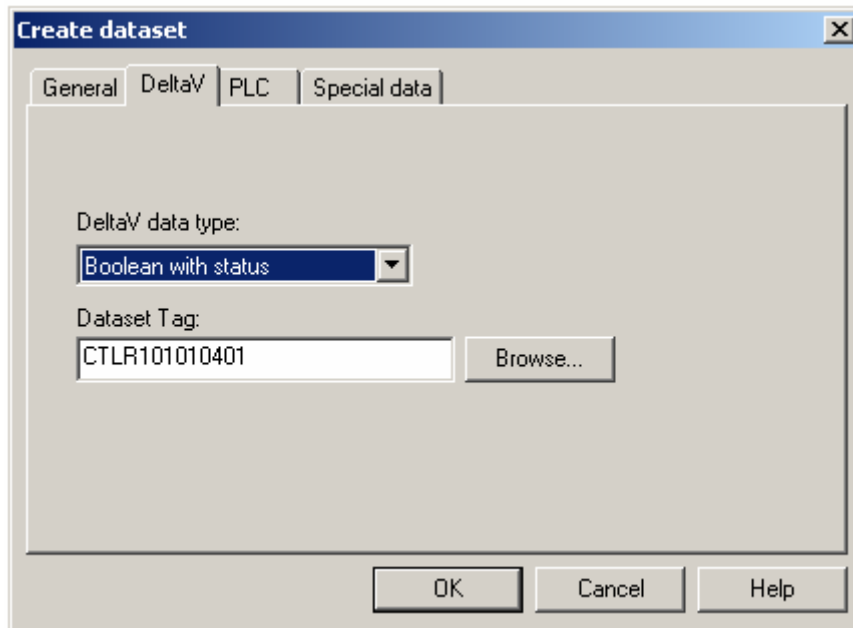



Create dataset [X]

General | DeltaV | PLC | **Special data**

Device data type:

Data start address: Number of values:

OK Cancel Help

Create dataset [X]

General | DeltaV | PLC | **Special data**

Special data 1

Special data 2

Special data 3

Special data 4

Special data 5

OK Cancel Help



Dataset 2 dialogs:

Table 15

Device#	Dataset#	Data Type	Start Address	Number of Values	Special Data
4	2	Boolean	4200	66	All 0

The screenshot shows the 'Create dataset' dialog box with the 'DeltaV' tab selected. The 'DeltaV data type' dropdown is set to 'Boolean with status'. The 'Dataset Tag' field contains 'CTLR101010402'. There is a 'Browse...' button next to the tag field. At the bottom are 'OK', 'Cancel', and 'Help' buttons.

The screenshot shows the 'Create dataset' dialog box with the 'PLC' tab selected. The 'Device data type' field contains '0'. The 'Data start address' field contains '4200'. The 'Number of values' spinner is set to '66'. At the bottom are 'OK', 'Cancel', and 'Help' buttons.

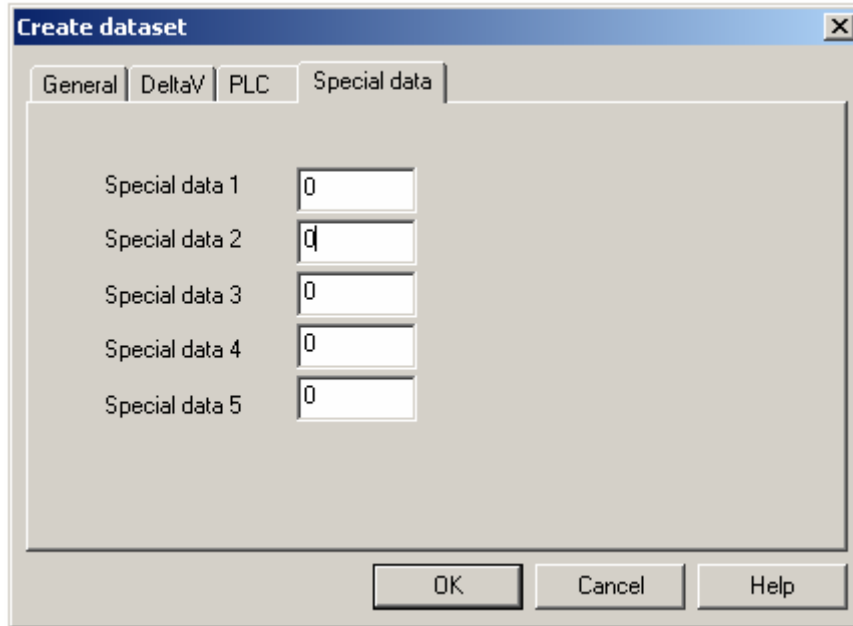

Dataset 3 dialogs:

Table 16

Device#	Dataset#	Data Type	Start Address	Number of Values	Special Data
4	3	16 bit UINT	4300	32	All 0

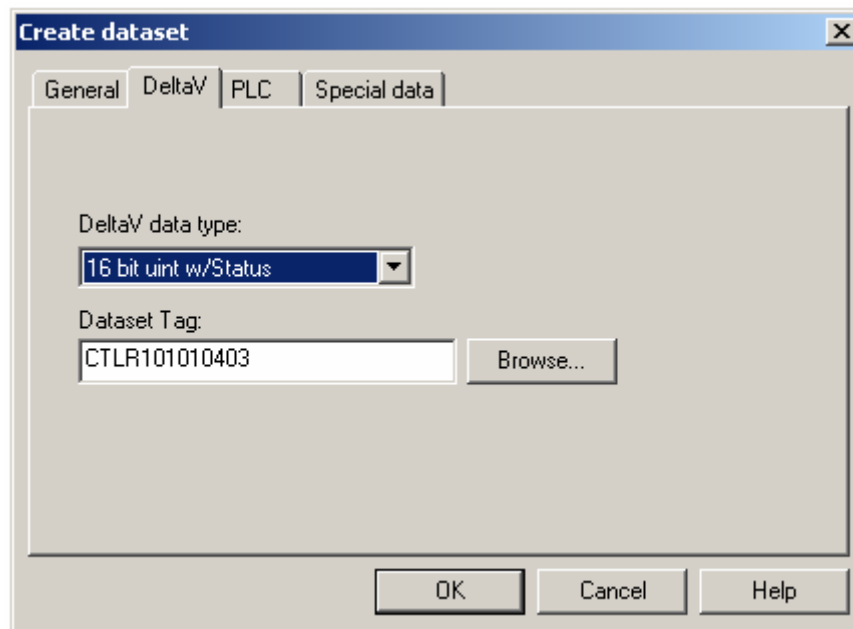



Create dataset [X]

General | **DeltaV** | PLC | Special data

DeltaV data type:
16 bit uint w/Status

Dataset Tag:
CTRL101010403 [Browse...]

OK Cancel Help

Create dataset [X]

General | DeltaV | **PLC** | Special data

Special data 1 [0]
Special data 2 [0]
Special data 3 [0]
Special data 4 [0]
Special data 5 [0]

OK Cancel Help



Dataset 4 dialogs:

Table 17

Device#	Dataset#	Data Type	Start Address	Number of Values	Special Data
4	4	16 bit UINT	4400	16	All 0

Create dataset

General | **DeltaV** | PLC | Special data

DeltaV data type:

Dataset Tag:

Create dataset

General | DeltaV | **PLC** | Special data

Device data type:

Data start address: Number of values:



The image shows a software dialog box titled "Create dataset". It has four tabs: "General", "DeltaV", "PLC", and "Special data". The "Special data" tab is selected. Inside the dialog, there are five rows, each with a label "Special data 1" through "Special data 5" and a corresponding text input field. All five input fields contain the number "0". At the bottom of the dialog, there are three buttons: "OK", "Cancel", and "Help".



Step 7:

After completing the Card configuration, download the card. Connect the Port 1 twisted pair cable between the Serial Card Termination and the Comm Term Panel. RS3 communications will start immediately. On the RS3 Console, the File Status for the given controller will appear as follows:

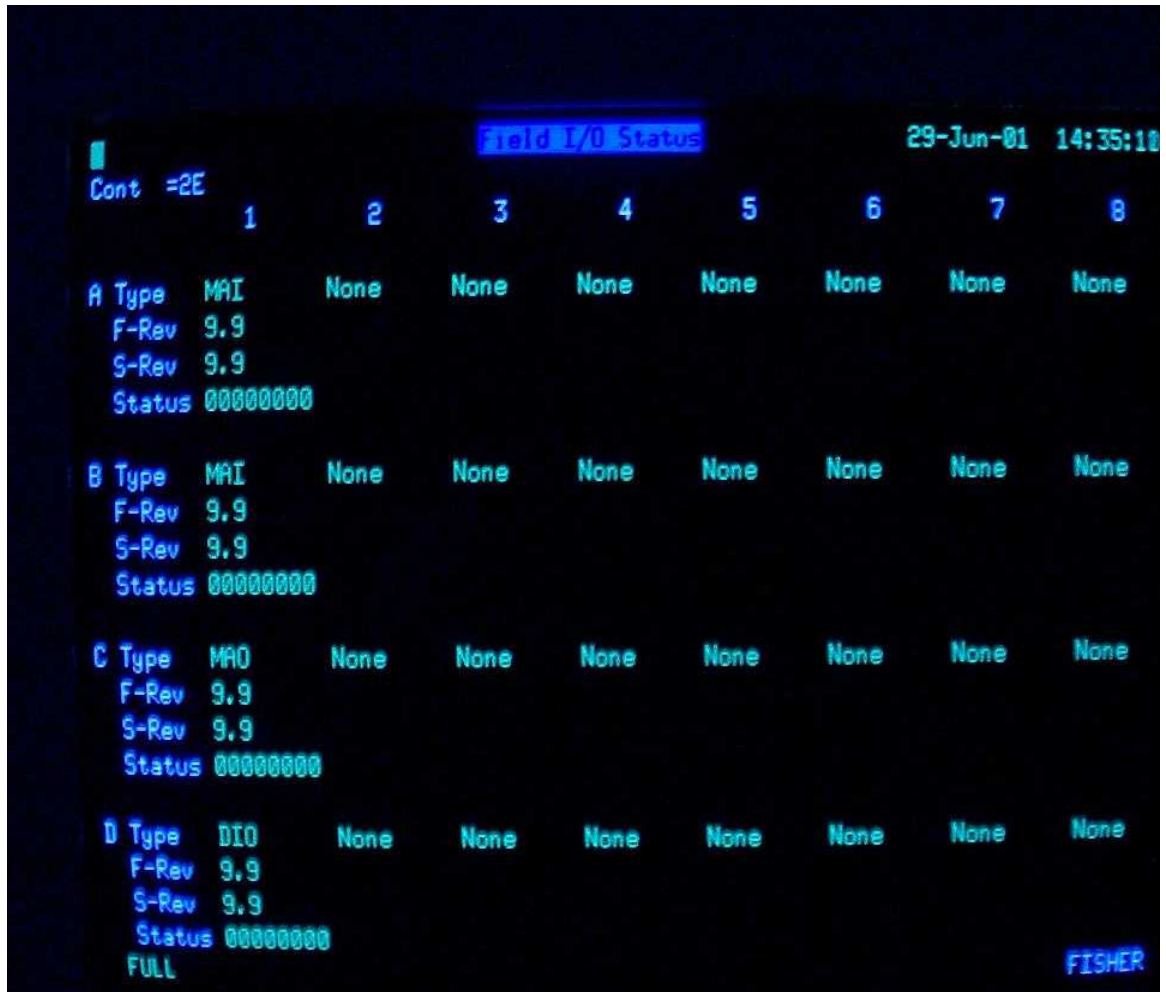

Note that for emulated FIMS, the F-Rev and S-Rev parameters will always appear as 9.9. In all other respects, this I/O is identical to Real RS3 I/O, and should be configured as such. For example, the following shows an Analog Input Block tied to the first channel of the first emulated FIM-MAI.

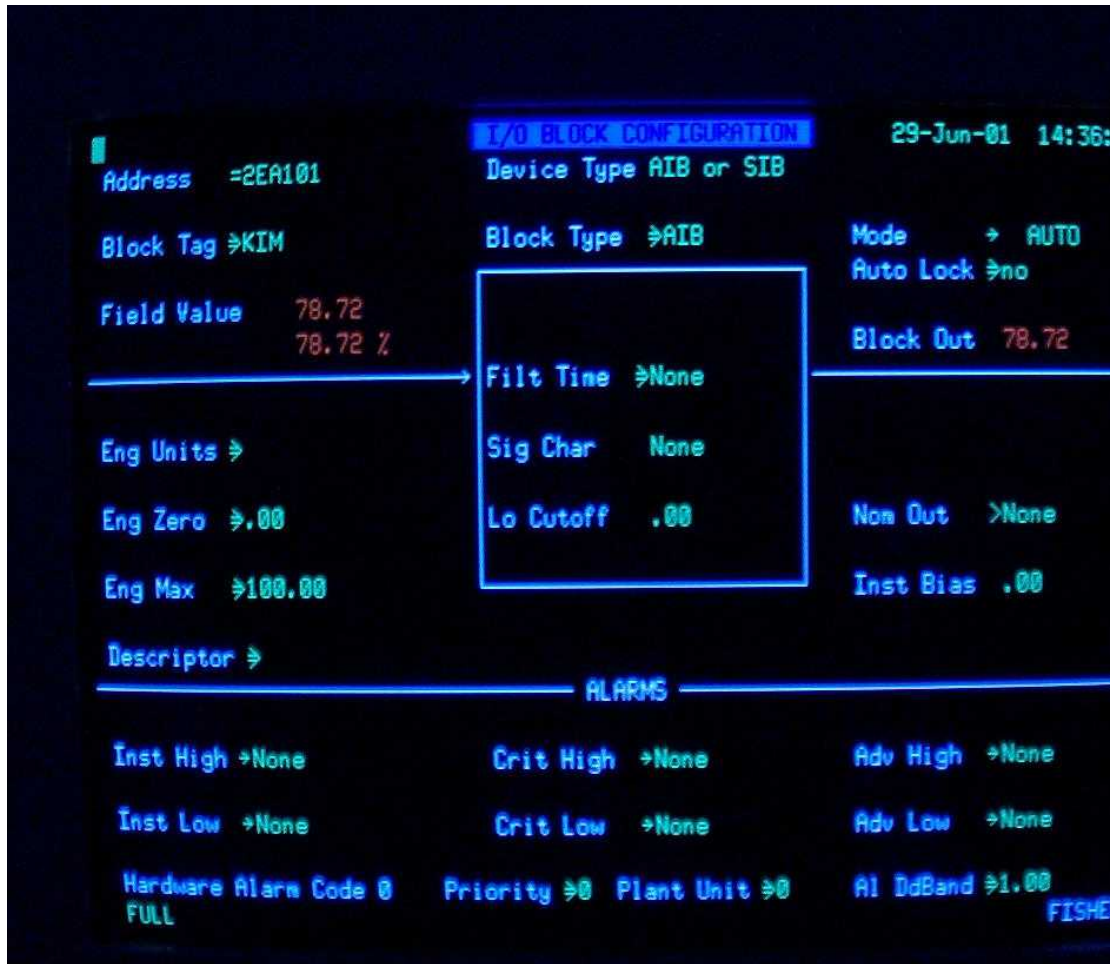



9 What's New in this Release?

9.1 Release Notes for v1.11s

Release v1.11s has the following changes, which correct or enhance driver functionality.

1. Watchdog timer – Previous versions of the driver continued communications interchange with RS3 even when the DeltaV Controller was not online. RS3 continued to see emulated I/O as good, even though it was offline. This was a defect, which has been corrected. With v1.11s, if the DeltaV controller goes offline for any reason, the Virtual RS3 driver will stop communications with RS3. RS3 will no longer see the emulated I/O as good.
2. In some cases, the programmable serial card did not get downloaded when the DeltaV was downloaded. Users had to perform an individual card download to complete the download process. With v1.11s, the driver is more responsive to download commands from the DeltaV Controller.
3. Hardware failure for FIM-DIO channels was always reported in groups of 8 channels, even though only 1 channel failed. This is actual functionality of the real DIO Fims, and was not required in the Virtual RS3 driver (since there is no real Fim present). This functionality is left intact for backward compatibility of existing sites using this driver.
4. There was no way to generate a DO Feedback check error in DIO Fims. The RS3 commanded state was always returned back, regardless of actual DO state. With v1.11s, users have the functionality to generate Feedback check errors.

9.2 Release Notes for v1.12s

1. Release 1.12s corrects errors in DIO feedback check handling.

9.3 Release Notes for v1.13s

1. The driver has been rebuilt using the Emerson Serial Driver Toolkit v 2.2. No code changes have been made.