



M Y N A HSM

**Brooks Petrocount Driver
Programmable Serial Interface Card
Series 2**

USER MANUAL

Rev. P1.11

February 22, 2006

DeltaV is a trademark of Emerson Process Management, All rights reserved.

Printed in the U.S.A.

While this information is presented in good faith and believed to be accurate, MYNAH Technologies does not guarantee satisfactory results from reliance upon such information. *Nothing contained herein is to be construed as a warranty or guarantee, express or implied, regarding the performance, merchantability, fitness or any other matter with respect to the products*, nor as a recommendation to use any product or process in conflict with any patent. MYNAH Technologies reserves the right, without notice, to alter or improve the designs or specifications of the products described herein.



1 INTRODUCTION

1.1 Scope

This document is the User Manual for the Brooks Petrocount driver firmware for the Emerson Process Management (EPM) DeltaV Control System; it provides information required to install, configure, and maintain the driver firmware on the DeltaV Series 2 Programmable Serial Interface Card (PSIC). The reader should be familiar with EPM's DeltaV PSIC and connected Brooks Petrocount devices.

The section *Document Format* briefly describes the contents of each section of this manual. *System Specifications* outlines hardware and software requirements for the Brooks Petrocount Driver (P1.11) firmware.

1.2 Document Format

This document is organized as follows:

Table 1

Introduction	Describes the scope and purpose of this document.
Theory of Operation	Provides a general functional overview of the Brooks Petrocount Driver.
Downloading Firmware	Describes downloading procedures for the Brooks Petrocount Driver firmware on to the DeltaV PSIC.
Configuration Information	Describes procedures and guidelines for configuring the DeltaV PSIC.
Operational Check	Provides tips and assistance to ensure PSIC is properly setup and configured.
DeltaV–Field Device Electrical Interface	Describes the electrical interface between DeltaV and the Brooks Petrocount device. Also describes the cable pin assignments for RS-232 and RS-422/485 communications.
Technical Support	Describes who to call if you need assistance.
Example	Describes how to configure a device with input and output datasets.



1.3 System Specifications

The following table lists the minimum system requirements for the Brooks Petrocount Driver:

Table 2

Firmware	Brooks Petrocount Driver Firmware (P1.11)
Protocol Compatibility	Brooks Petrocount – Data Communications Interface, User Guidelines.
Software Requirements	DeltaV System Software (Release 6.3.2 or later) installed on a hardware-appropriate Windows NT or later workstation configured as a ProfessionalPlus for DeltaV Serial Interface Port License (VE4102)
Minimum DeltaV Hardware Requirements	EPM DeltaV Serial Interface Series 2, Hardware PN: 12P2506X022 EPM DeltaV M3, M5, MD or Series 1 MD Controller, Power Supply and 2 wide controller carrier EPM 8 wide I/O card carrier



2 THEORY OF OPERATION

The Programmable Serial Interface Card (PSIC) has 2 ports which can be configured for RS-232, RS-422/RS-485 Half Duplex or RS-422/RS-485 Full Duplex communications with external devices. For communications with the Brooks devices, any mode may be used. When using RS-422/RS-485 Half/Full Duplex, the driver can communicate with one or more Brooks devices on each port. In this mode, all connected Brooks devices must be configured to use RS-422/RS-485.

The DeltaV Serial Card Driver functionality will be as follows.

1. The driver will run in Master mode only and be responsible for sending commands to the Brooks devices. The Brooks devices will respond with register information, which will be reported to DeltaV in dataset registers. The Brooks device must be in Computer Mode.
2. The two ports of the PSIC work independently, each connected to one or more Brooks devices.
3. Each port contains 16 datasets. A dataset can have a maximum of 100 16-bit registers, or fifty (50) 32-bit/floating point registers. The 16 datasets can be divided over several devices. Each device has a unique address. A port can have a maximum of 16 devices, each with 1 dataset.

The following shows PSIC connectivity with Brooks devices.

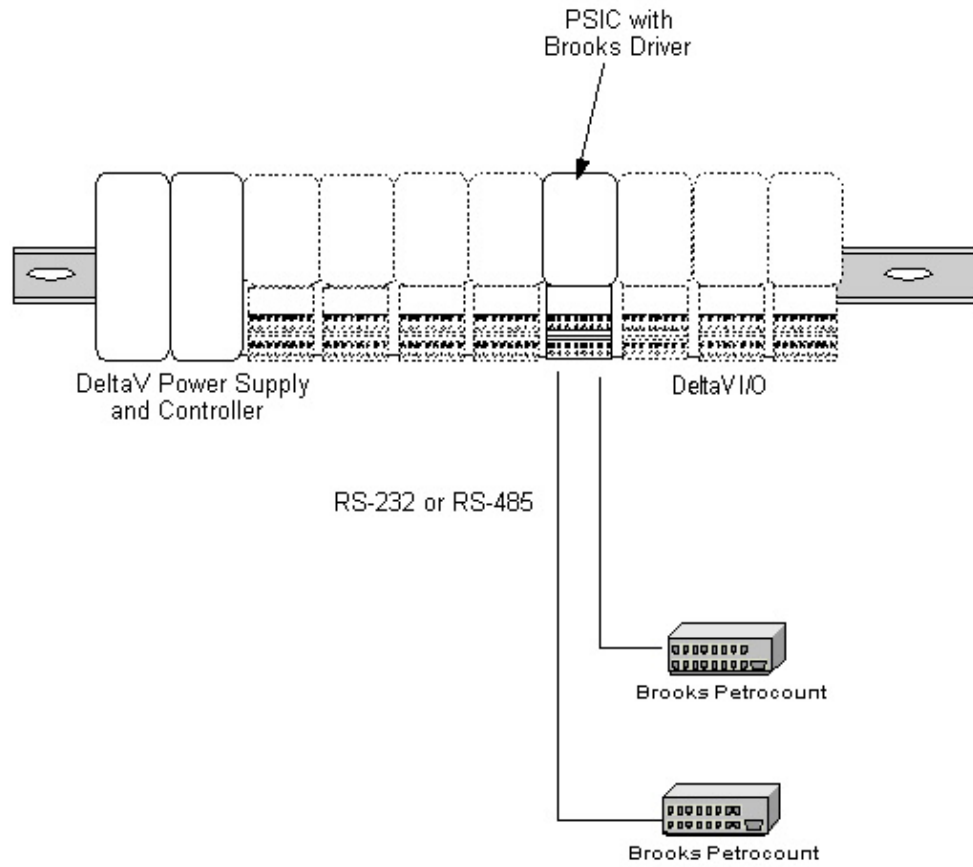



3 Downloading the firmware

The driver software distribution comprises 15 files, distributed on a CD. These files must be copied to the DeltaV directory on your ProPlus Workstation. The path is:

\\DeltaV\ctl\ProgSerial\S2-Brooks

Note that you will have to create the \Brooks subdirectory. The following files will be copied:

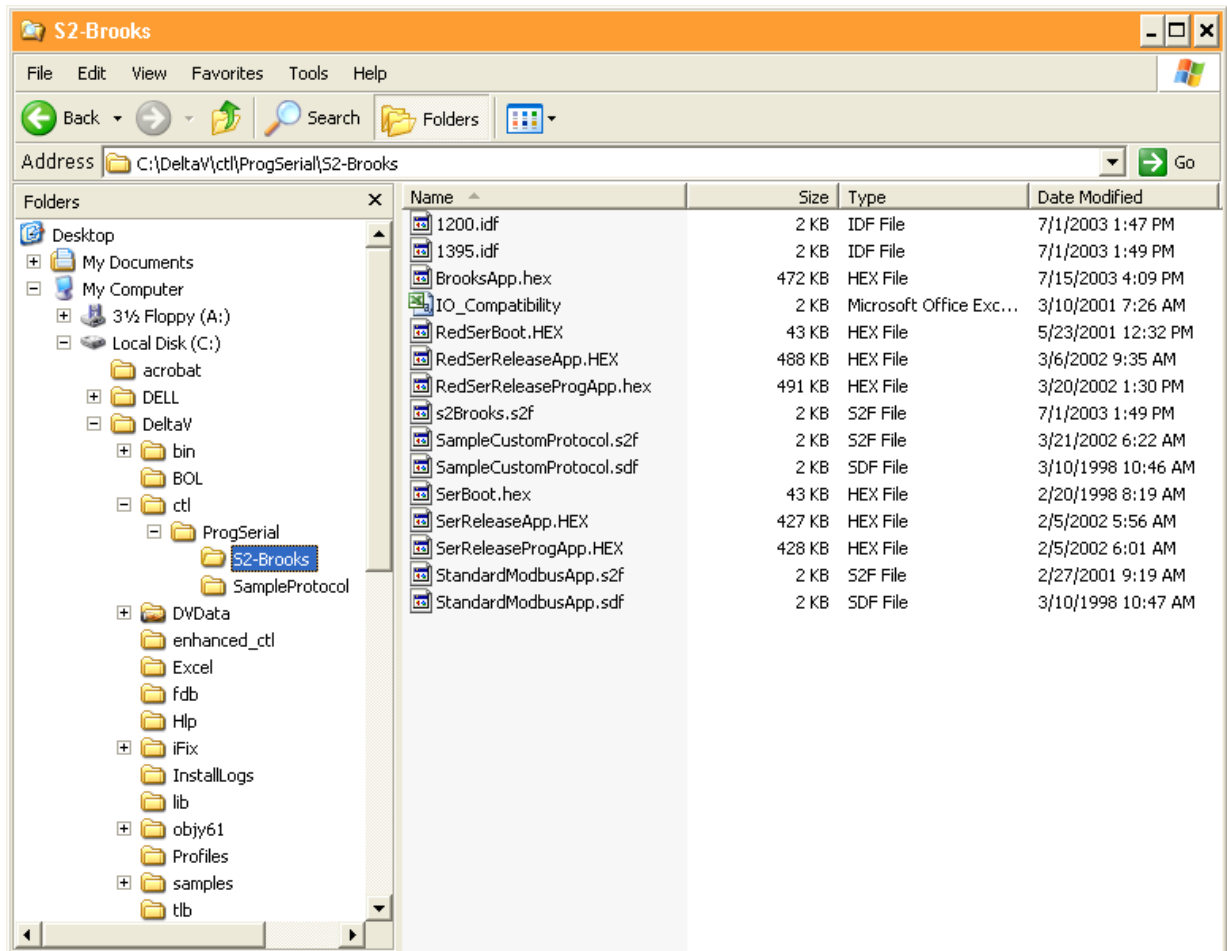



After copy completion, you are ready to program (or upgrade) the Programmable Serial Card with the supplied custom driver software. The steps are as follows:

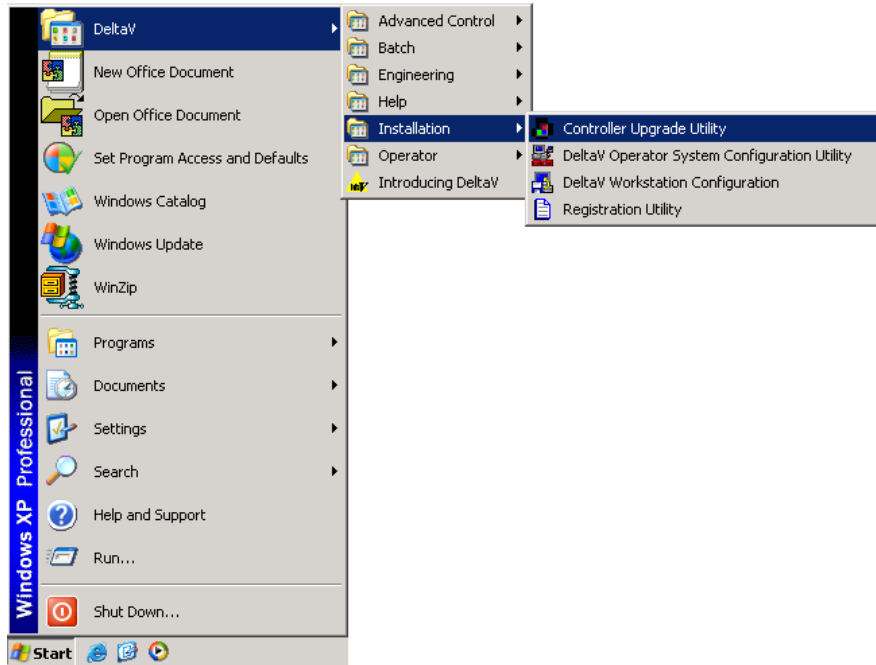

1. Click on the Start button and select DeltaV-> Installation-> Controller Upgrade Utility as shown below, and the following dialog will appear:

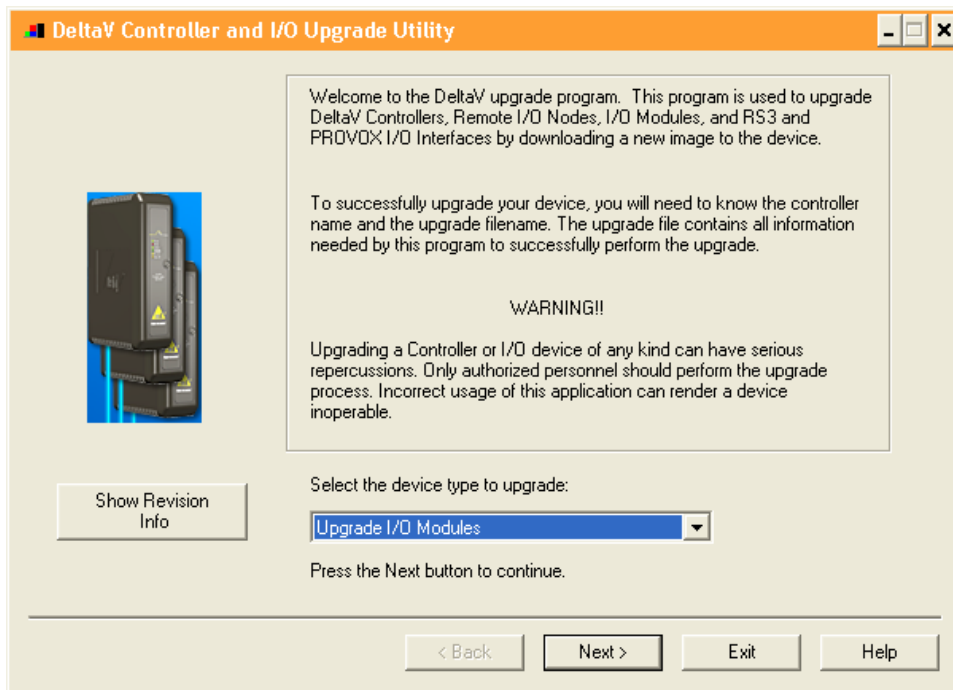

2. Choose Upgrade I/O Modules from the drop down menu and click Next.

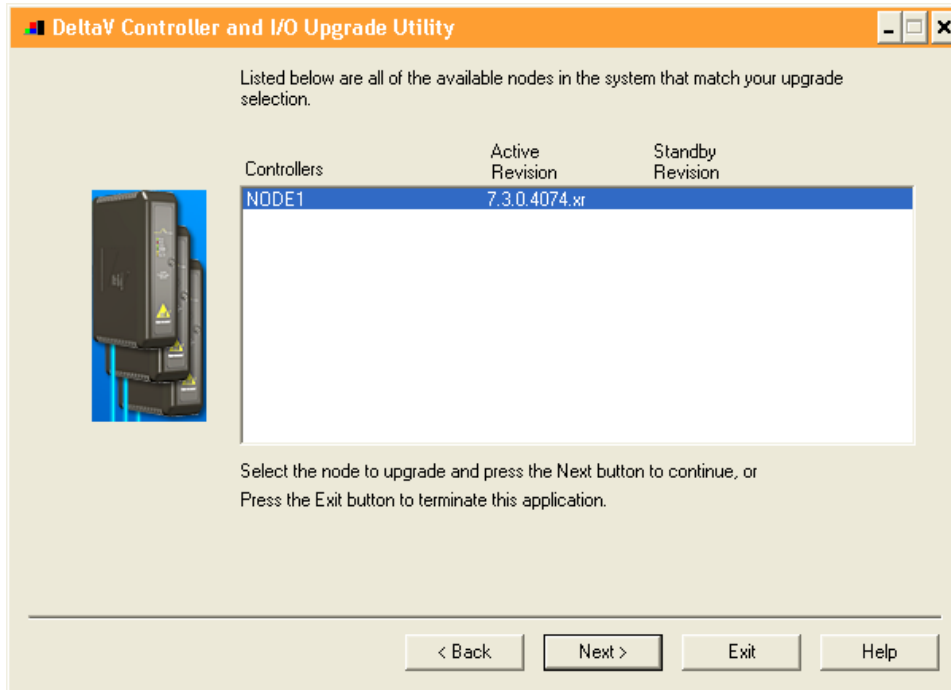

3. The above dialog will appear, listing all the available Controllers in your network. From this dialog, select the appropriate Controller and then Click Next.

4. The following dialog will appear, listing all the I/O modules in your selected Controller. The shown list of I/O modules is an example only. Your list will be different.

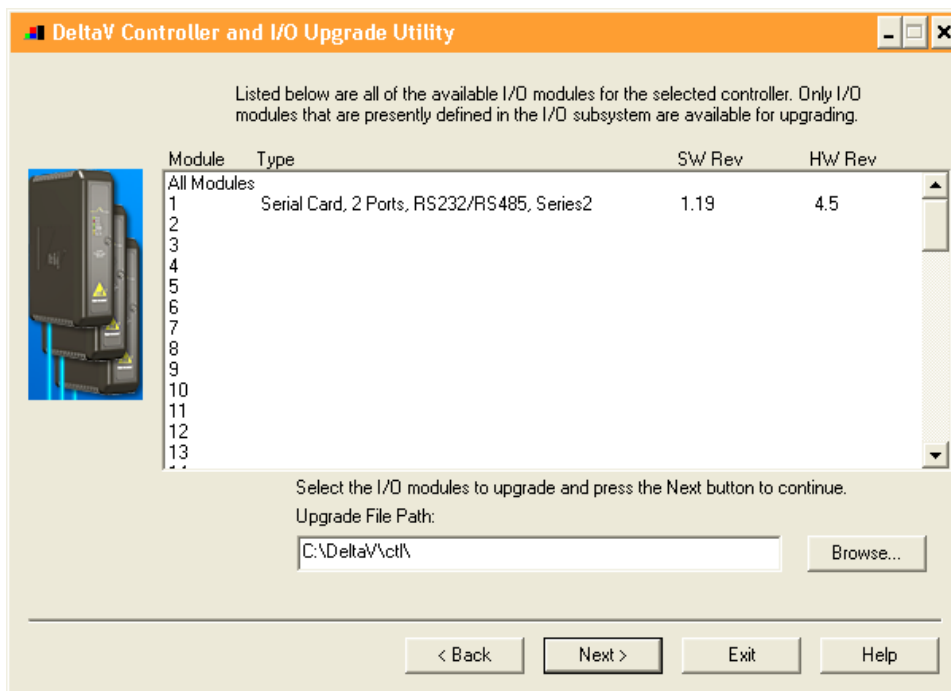



Note: The first time a standard Serial card is upgraded to the Brooks Petrocount RMS Driver, the dialog will be as shown below. When upgrading an existing Programmable Serial Card, skip Steps 4, 5 and 6, and go to Step 7.

5. Click the Browse button and select the DeltaV path as shown below, and then click Ok. Note that the disk drive could be C or D.

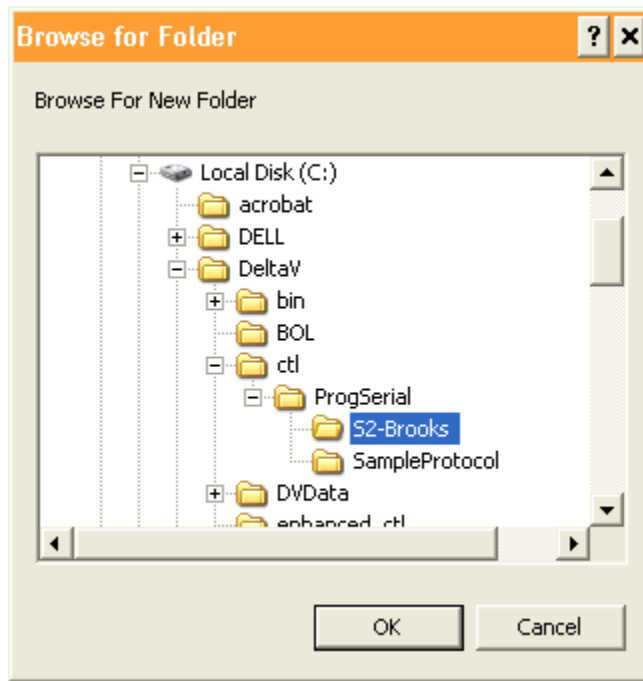

6. Select the I/O module again as shown below and then click Next. Go to Step 9.

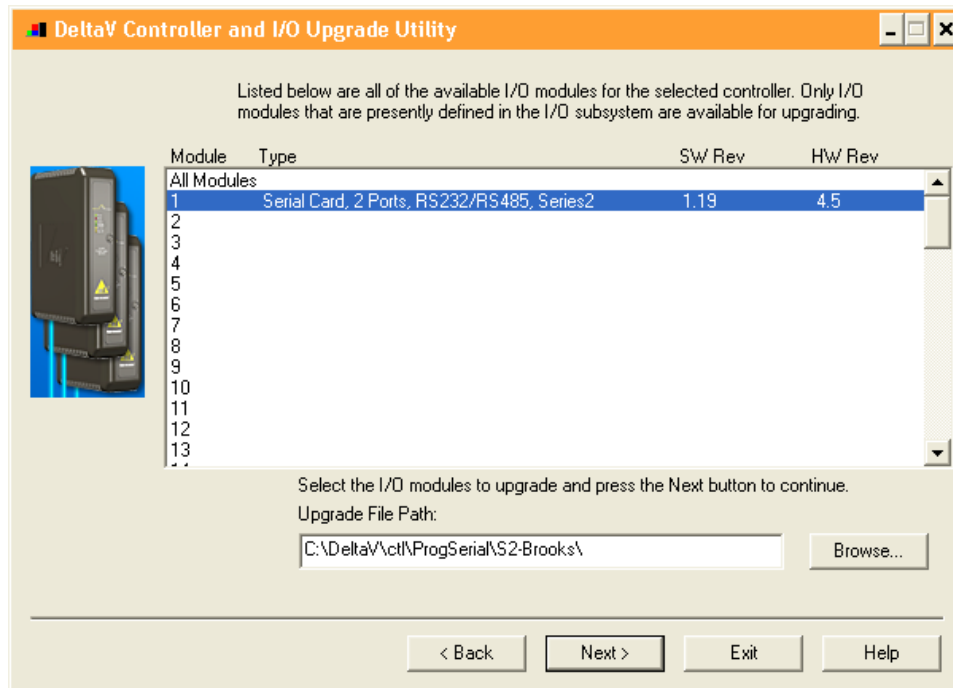



7. If you are upgrading an existing Programmable Serial Card, the dialog will be as shown below. From this dialog, select the Programmable Serial Card I/O Module in the list.

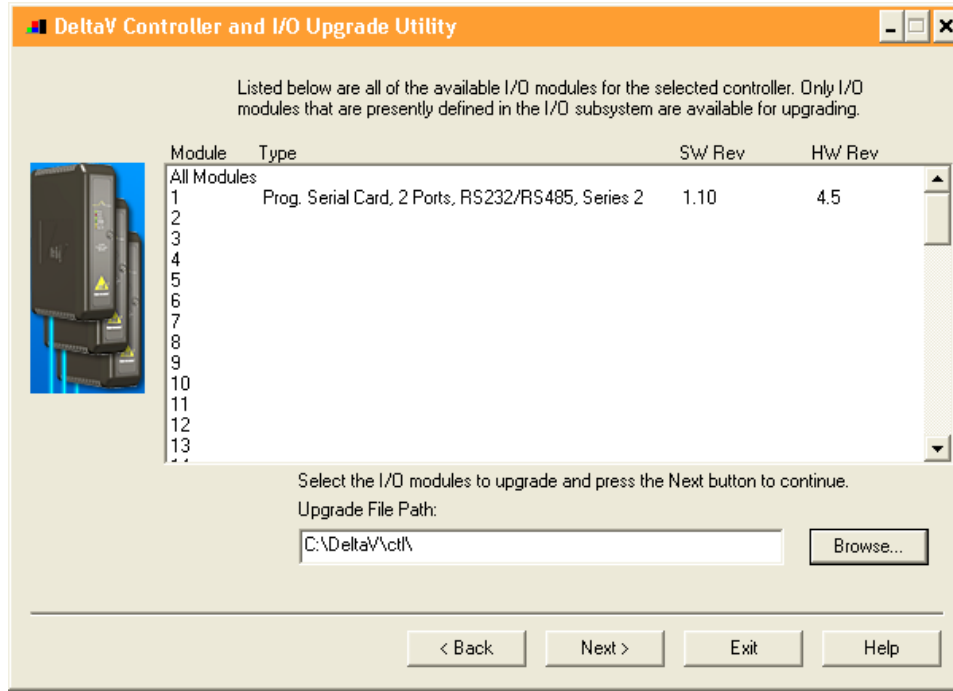

For example, we will select I/O Module 1. This will give you a dialog, from which you will select the file path to where the driver software is located. This path will be:

\\DeltaVctl\ProgSerial \S2-Brooks

Once you are in the specified directory, you will need to select the following file:

s2Brooks.S2F

This is shown in the following dialog.

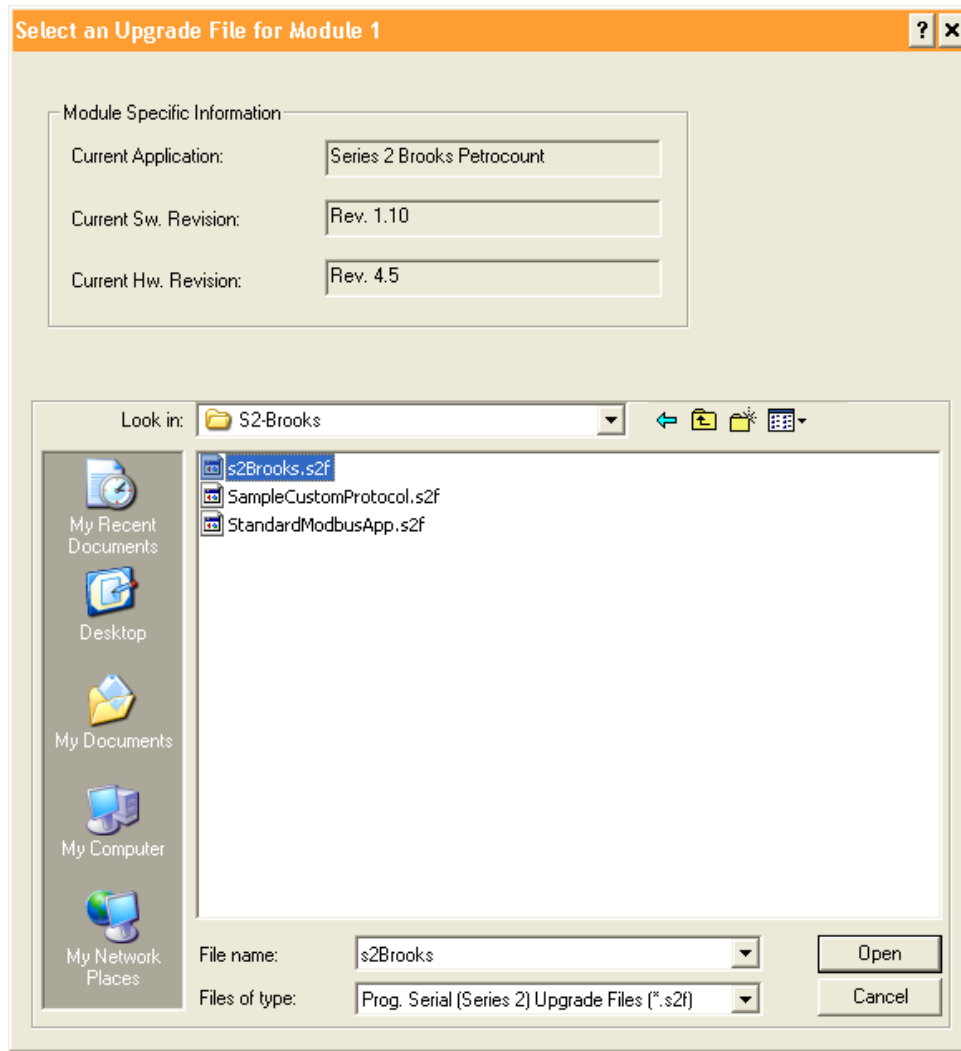

8. After selecting the .S2F file, Click on Open. This dialog will close and you will be back to the following:

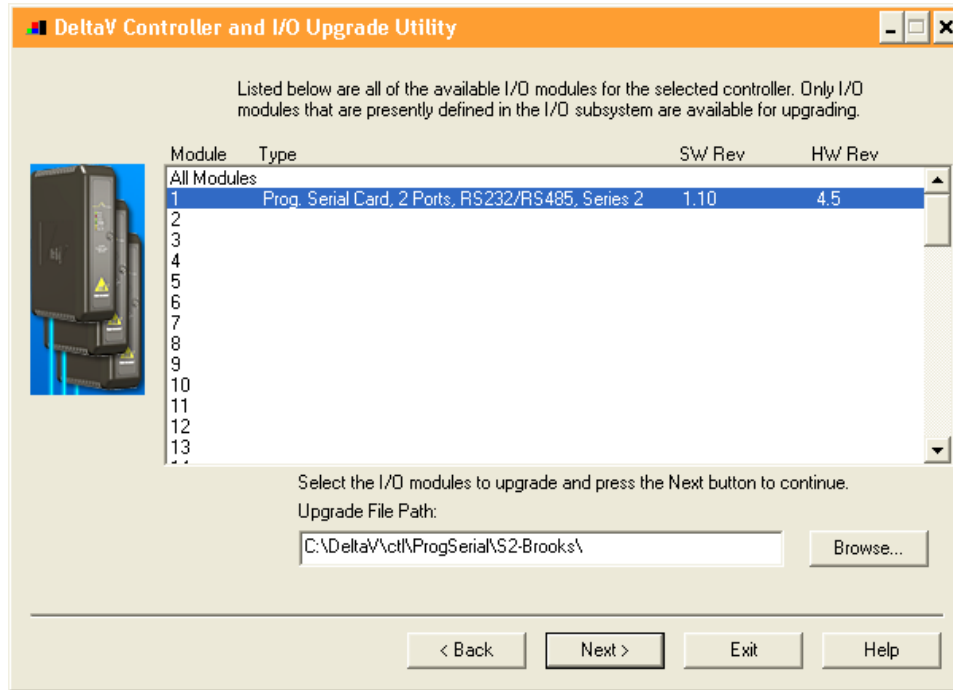

9. In this dialog, Click Next again. You will get the following dialog, confirming the Controller and I/O Module to program.

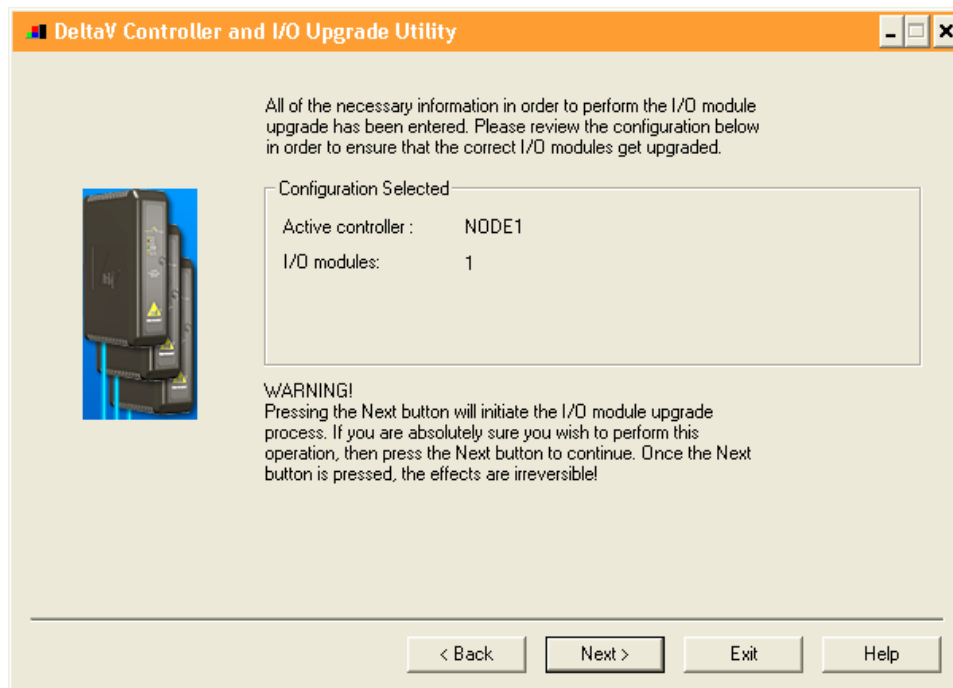



10. Click Next and the I/O Module upgrade process will begin. After completion, you will receive the following dialog, indicating success.

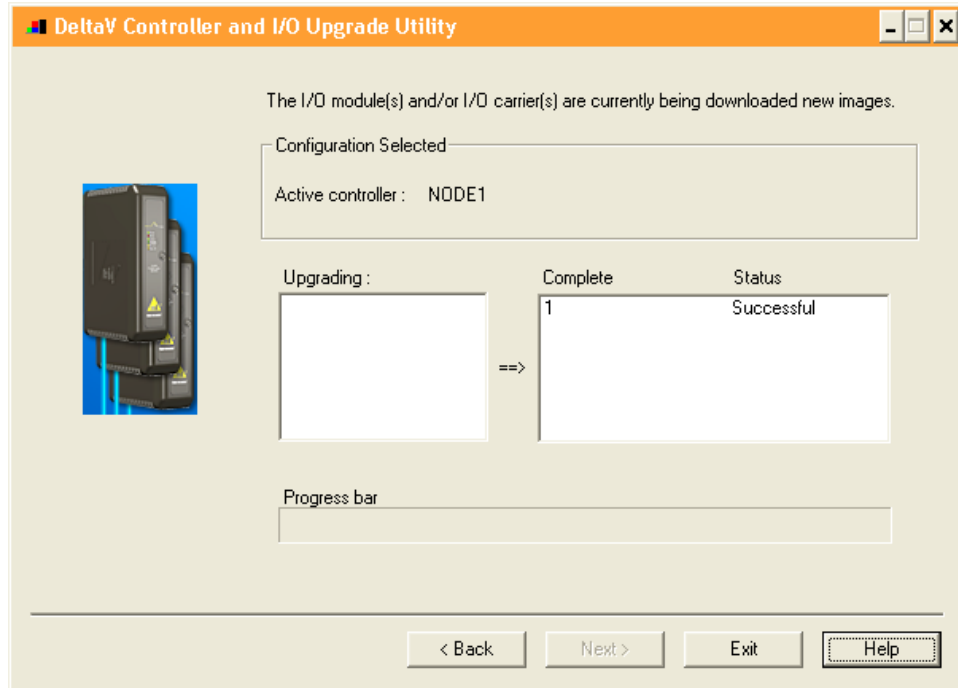

11. This completes the I/O Module upgrade process.



4 CONFIGURATION INFORMATION

The DeltaV Explorer view of a configuration containing a Programmable Serial Card will be as follows, where C01 has a card type of Programmable Serial Card, P01 and P02 are the ports on the card, DEVXX are devices attached to the ports, and DSXX are configured Datasets for each device.

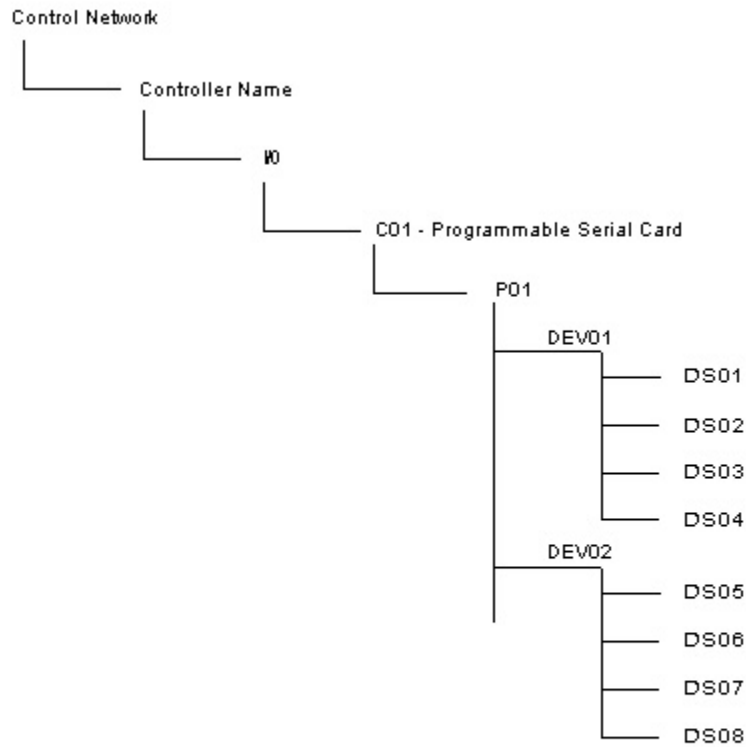



The Brooks device network uses a source and destination address. When configuring DeltaV to communicate with Brooks devices, it must identify itself with a unique source address so that the Brooks devices know who is requesting the data. A sample configuration below shows how one would configure DeltaV to request 10 registers from a Brooks device at address 007 and 10 registers from a Brooks device at 043.

Sample Network

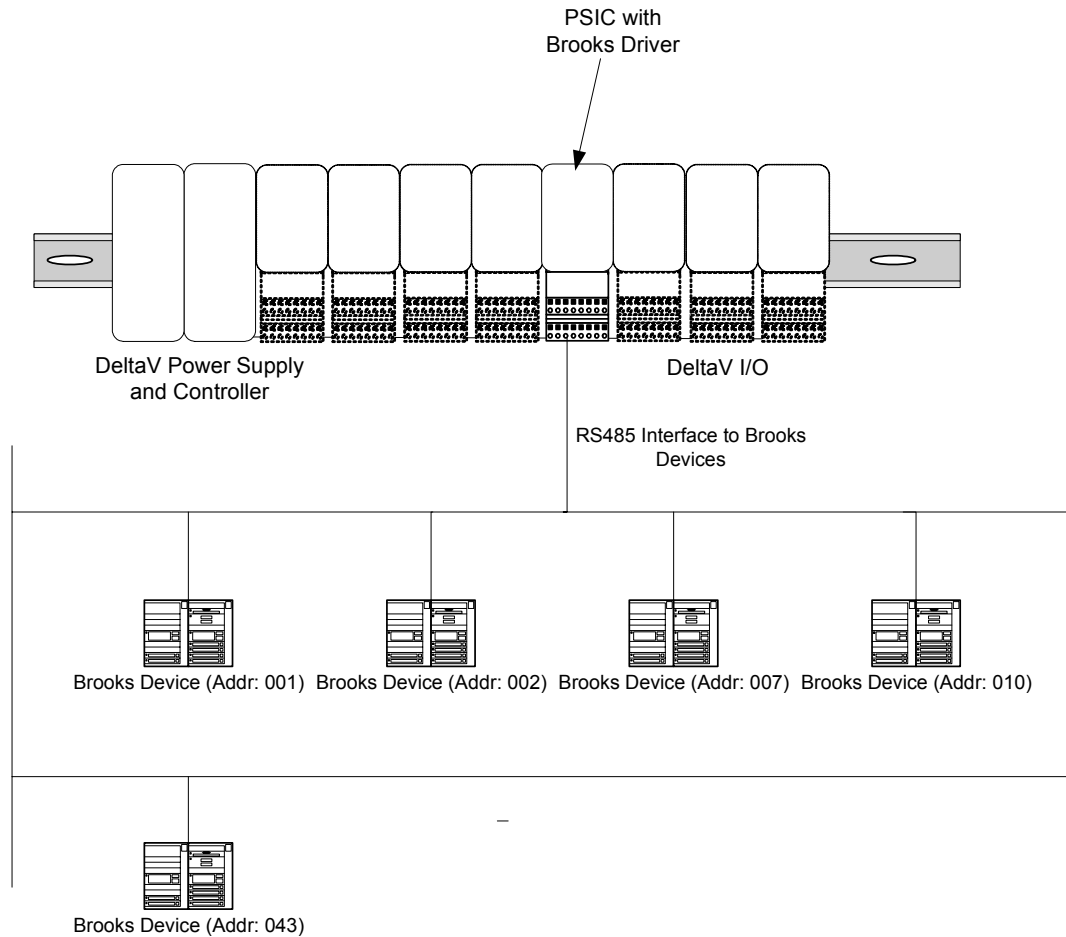

First we must choose an address for DeltaV. The address must be unique so for this example I have chosen 003 since it would not conflict with any existing devices on the Brooks multidrop network. Remember to pick a number that will not conflict with existing devices and is not likely to be used if new devices are added.

Once the serial card is flashed and DeltaV is wired up to the Brooks network, enable the port in DeltaV and define 2 devices. The device address will represent the 2 Brooks devices we intend to communicate with. In this example we would like to read registers from Brooks devices at address 007 and 043. Device 1 in DeltaV should be created with device address 7 and Device 2 in DeltaV should be created with device address 43.

Next we will define 1 dataset under each device. The first dataset under device 1 will be defined as input since we only want to read 10 registers in this example. The DeltaV Data Type is dependant on how the incoming data is to be represented. In this example we'll



M Y N A H™

POWERFUL SOLUTIONS FOR DIGITAL PLANTS

use 16-Bit unsigned int. For this driver the Device Data Type must always be 15, all others are reserved. The start address and number of values is dependant on which registers you intend to read. For this example we'll use a start address of 800 and we'll read 10 values. The last item that must be configured is Special Data 1. This will hold the address we have assigned to DeltaV. Since we have assigned DeltaV the address of 003 we'll place a 3 in special data 1, the leading 0's are not necessary.

A similar configuration will be done to the dataset defined under device 2.

Once the card is configured and downloaded, DeltaV will begin to poll the registers in the Brooks devices and the responses will appear in the datasets.



4.1 Port Configuration

First, enable the port. Then click on the Advanced Tab and Master mode. Slave is not supported. Specify the retry count, message timeout value in milliseconds, and message delay time. In most cases, you can leave these at their default values. Next, click on the Communications Tab and specify the Port type. The Port type will be RS-232 or RS-422/RS-485. In general, RS-232 will be used for Brooks communications, unless there are distance limitations or multi-drop requirements. Lastly, select the Baud rate, Parity, Data bits and Stop bits parameters; these must match the Brooks settings.

4.2 Device Configuration

Specify devices, as shown above. For each device set the corresponding Device Address to match that of the Brooks you want to communicate with.

4.3 Dataset Configuration

Dataset parameters are used to read/write registers. Configure the parameters as follows:

Note that because the Brooks protocol is ASCII, there is a limit on the number of registers which can be read/written by a single command. Furthermore, ASCII protocols are slow. Consequently, update times will be slow.

4.3.1 Data Direction

The Data Direction for can be defined as Input or Output.

4.3.2 Output Mode

The Output Mode 0 is for block writes. If configured the entire dataset is written when a single register changes. This is typically not recommended for Brooks devices. Output Mode 1 is for single value writes. When a particular register changes, only that register is written out. Using single value writes is the preferred mechanism.

4.3.3 DeltaV Data Type

The DeltaV data type can be 16-bit, 32-bit, floating point as needed.

4.3.4 DeviceDataType

The Device Data Type must be configured as 15. All other values are reserved, and are for backward compatibility with older configurations.

4.3.5 Data Start Address and Number of Values

The start address indicates the starting register in the Brooks device where reads/writes will begin. The number of values indicates how many consecutive registers will be accessed. Start addresses are typically configured as decimal values. For example, to read/write Brooks register 828, configure the Start Address as 827. Consequently, the first dataset register in DeltaV will be 828, and all read/write commands will use 828.



There exist in the Brooks device certain registers which have a Hexadecimal, for example, 82F. Since Hexadecimal numbers cannot be directly configured in DeltaV, the following mechanism should be used. First convert the Hexadecimal register number to decimal, and configure this in the Start Address field. For example, for 82F, configure 2094. With this value, the first dataset register will be 2095. Furthermore, configure a 1 in the SpecialData5 value for this dataset. This flags the driver to interpret the Start Address as a Hexadecimal value. Consequently, the read/write command sent to Brooks has 82F in it.

4.3.6 Special Data

Special Data 1 is used to represent the DeltaV address. Select a unique address with maximum 3-digits.

In certain cases, as described above, Special Data 5 is used as a flag for the driver to interpret the Start Address as a Hexadecimal value.

All others should be left as default.

5 Operational Check

5.1 Scope

The following sections provide some assistance to ensure the interface is working properly.

5.2 Verify Hardware and Software Version Number

The user can verify that the BROOKS driver has been installed using the DeltaV Diagnostics tool. The Diagnostics tool will show the Hardware Revision No. (HwRev) and the Software Revision No. (SwRev).

To begin the DeltaV Diagnostic tool select Start-> DeltaV-> Operator-> Diagnostics. In the Diagnostics tool expand the Controller, I/O and then double click on the Programmable Serial Interface Card that has the driver installed.

The following information will be displayed:

:	:	:
HwRev	Hardware Revision	1.10 (or later)
SwRev	Software Revision	2.3 (or later)

5.3 Verify Configuration

- Verify port configuration: The serial port must be enabled. User needs to make sure communication settings such as baud rate, parity, and number of data bits match the field device settings.
- Verify dataset configuration: The datasets configured must be as shown above.



5.4 Verify I/O Communication With Control Studio

User can create I/O modules in the control studio to verify correct values are being written out. An example module is shipped with the distribution. This module shows methods for writing text to the datasets and also how to handle time.

5.5 Using Diagnostics

- Verify PSIC communication: Select the PSIC on Diagnostics and press the right mouse button. Select Display Real -Time Statistics from the drop down menu. If the Programmable Serial Interface Card is functioning then the user will see the Valid Responses counter and the Async and/or Sync Transactions counter incrementing. There will not be any error counting up.
- Verify port statistics: Select the Port on the Programmable Serial Interface Card and press the right mouse button. Then select Display Port Statistics form the drop down menu. Verify that the port communications statistics are being displayed properly and are counting as expected for the protocol's functionality.
- Verify dataset values: Select a dataset and press the right mouse button. Select View Dataset Registers from the Drop down window. Verify that the dataset values are displayed as expected.

5.6 LED Indication

The Yellow LED for the port should be on solid when all communications on that port are valid. The Yellow LED should be blinking if there is some valid communications and some communications with errors on that port. The Yellow LED should be OFF if there are no valid communications on that port.



6 DeltaV–Field Device Electrical Interface

The electrical interface between DeltaV and field devices conforms to the RS-232 and RS-422/485 standards.

Each PSIC has 2 ports, which function independently. The distance between the serial card and the field device can be as much as 5000 feet, per the RS-422/485 standard. When using RS-232, the distance is limited to 50 feet. Section 6.1 shows the pin assignments for the PSIC serial terminal block.

6.1 Pin Assignments for DeltaV PSIC

RS-232 Standard

Table 6

Terminal Number	Signal Description
1	Port 1 - Isolated Ground (GND)
2	Unused
3	Port 1 – Transmit Data (TxD)
4	Unused
5	Port 1 – Receive Data (RxD)
6	Unused
7	Port 1 – Data Terminal Ready (DTR)
8	Port 1 – Data Set Ready (DSR)
9	Port 2 - Isolated Ground (GND)
10	Unused
11	Port 2 – Transmit Data (TxD)
12	Unused
13	Port 2 – Receive Data (RxD)
14	Unused
15	Port 2 – Data Terminal Ready (DTR)
16	Port 1 – Data Set Ready (DSR)



RS-422/485 Half Duplex Standard

Table 7

Terminal Number	Signal Description
1	Port 1 – Isolated Ground (GND)
2	Port 1 - Data +
3	Unused
4	Port 1 - Data -
5	Unused
6	Unused
7	Unused
8	Unused
9	Port 2 – Isolated Ground (GND)
10	Port 2 – Data +
11	Unused
12	Port 2 - Data -
13	Unused
14	Unused
15	Unused
16	Unused

RS-422/485 Full Duplex Standard

Table 8

Terminal Number	Signal Description
1	Port 1 – Isolated Ground (GND)
2	Port 1 – TxD +
3	Unused
4	Port 1 – TxD -
5	Unused
6	Port 1 – RxD +
7	Unused
8	Port 1 – RxD -
9	Port 2 – Isolated Ground (GND)
10	Port 2 – TxD +
11	Unused
12	Port 2 – TxD -
13	Unused
14	Port 2 – RxD +
15	Unused
16	Port 2 – RxD -



6.2 Wiring Connections

In general, the figure below shows the connections between the Field Device and the PSIC termination block. For additional DeltaV cabling information, please refer to the DeltaV Books Online documentation. For Brooks cabling information, refer to Brooks Petrocount Manual.

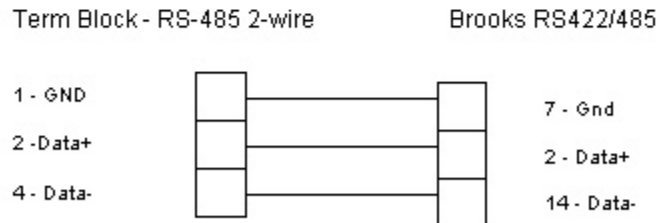
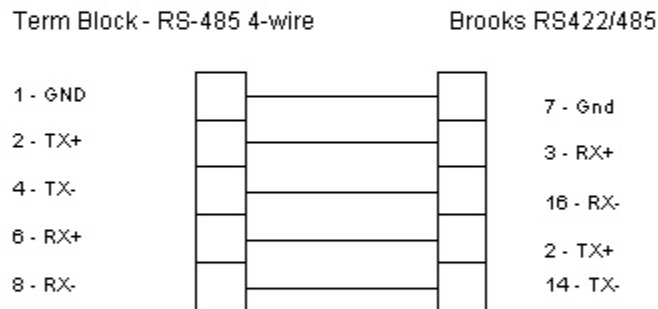
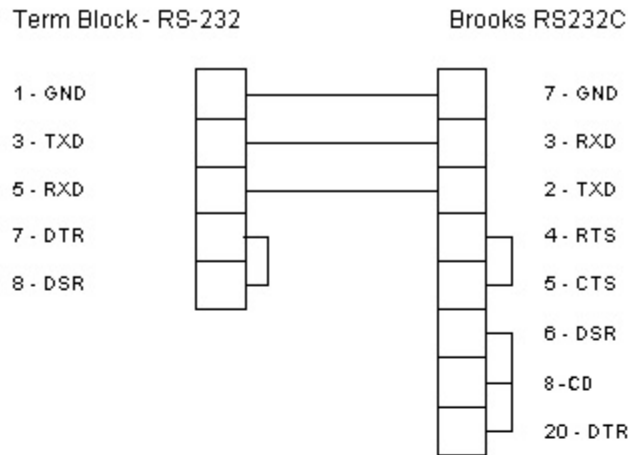



M Y N A H™

POWERFUL SOLUTIONS FOR DIGITAL PLANTS

7 Technical Support

For technical support or to report a defect, please give Mynah Technologies a call at (636) 681-1555. If a defect is discovered, please document it in as much detail as possible and then fax your report to us at (636) 681-1660.

You can also send us your questions via e-mail. Our address is:

support@mynah.com

Thank you for using DeltaV.