



M Y N A HSM

**ASCII Compressor Driver
Programmable Serial Interface Card
Series 2**

USER MANUAL

Rev. P1.10

March 8, 2004

DeltaV is a trademark of Emerson Process Management, Inc © Emerson Process Management, Inc. 1998, 1999.
All rights reserved.

Printed in the U.S.A.

While this information is presented in good faith and believed to be accurate, MYNAH Technologies does not guarantee satisfactory results from reliance upon such information. *Nothing contained herein is to be construed as a warranty or guarantee, express or implied, regarding the performance, merchantability, fitness or any other matter with respect to the products*, nor as a recommendation to use any product or process in conflict with any patent. MYNAH Technologies reserves the right, without notice, to alter or improve the designs or specifications of the products described herein.



1 INTRODUCTION

1.1 Scope

This document is the User Manual for the ASCII Compressor driver firmware for the Emerson Process Management (EPM) DeltaV Control System; it provides information required to install, configure, and maintain the driver firmware on the DeltaV Series 2 Programmable Serial Interface Card (PSIC). The reader should be familiar with EPM's DeltaV PSIC and connected serial printers or logging devices.

The section *Document Format* briefly describes the contents of each section of this manual. *System Specifications* outlines hardware and software requirements for the ASCII Compressor Driver (P1.10) firmware.

1.2 Document Format

This document is organized as follows:

Table 1

Introduction	Describes the scope and purpose of this document.
Theory of Operation	Provides a general functional overview of the Driver.
Downloading Firmware	Describes downloading procedures for the Driver firmware on to the DeltaV PSIC.
Configuration Information	Describes procedures and guidelines for configuring the DeltaV PSIC.
Operational Check	Provides tips and assistance to ensure PSIC is properly setup and configured.
DeltaV–Field Device Electrical Interface	Describes the electrical interface between DeltaV and the compressor device. Also describes the cable pin assignments for RS-232 and RS-422/485 communications.
Technical Support	Describes who to call if you need assistance.
Example	Describes how to configure a device with input and output datasets.



1.3 System Specifications

The following table lists the minimum system requirements for the ASCII Compressor Driver:

Table 2

Firmware	ASCII Compressor Driver Firmware (P1.10)
Protocol Compatibility	None – Data is the ASCII output of the Compressor. It is captured and parsed into dataset registers as described below.
Software Requirements	DeltaV System Software (Release 6.3.2 or later) installed on a hardware-appropriate Windows NT workstation configured as a ProfessionalPlus for DeltaV Serial Interface Port License (VE4102)
Minimum DeltaV Hardware Requirements	FRSI DeltaV Serial Interface Series 2, Hardware PN: 12P2506X022 FRSI DeltaV M3, M5, MD or Series 2 MD Controller, Power Supply and 2 wide controller carrier FRSI 8 wide I/O card carrier



2 THEORY OF OPERATION

The Programmable Serial Interface Card (PSIC) has 2 ports which can be configured for RS-232, RS-422/RS-485 Half Duplex or RS-422/RS-485 Full Duplex communications with external devices. For communications with ASCII devices, any mode may be used.

The DeltaV Serial Card Driver functionality will be as follows.

1. The driver will be flashed into the PSIC.
2. The driver will run in Slave mode only and be responsible for capturing the ASCII output text strings through the connected port. The captured data will be parsed and reported to DeltaV in dataset registers.
3. The two ports of the PSIC work independently.

The expected data format (in one line) is as follows. The line is terminated by a carriage return and line feed:

1. Line Number (1-100). Line number 100 is given by 0;
2. Eight individual PT exit thermocouple temperatures;
3. The mean PT exit temperature;
4. The exhaust temperature.

If the auxiliary log control facility is in use and the associated auxiliary inputs are connected, the log will also contain the following:

5. Gas generator speed (%);
6. Power turbine speed (%);
7. Fuel valve demand (deg).

The following excerpt describes the expected data format:

LOG INTERVAL = 1 SECS
TEMPERATURES IN DEGREES CELSIUS

	CH1	CH2	CH3	CH4	CH5	CH6	CH7	CH8	MEAN	CH9	NCT	NPT	FVA
1	431	408	434	442	432	420	431	433	428	416	89	103	40
2	430	409	434	441	434	421	430	434	429	416	89	103	40
3	429	411	433	444	431	423	429	434	429	414	89	103	40
4	432	409	436	442	433	420	432	433	429	415	89	103	40
5	432	408	433	442	432	419	430	433	428	415	89	103	40
6	431	407	433	441	433	418	431	432	428	416	89	103	40
7	432	408	432	442	434	421	430	431	428	417	89	103	40
8	433	409	434	442	434	421	432	431	429	416	89	103	39
9	428	410	432	445	430	424	430	434	429	414	89	103	40
10	429	411	431	445	431	424	429	436	429	415	89	103	40

3 Downloading the firmware

The driver software distribution comprises 15 files, distributed on a CD. These files must be copied to the DeltaV directory on your ProPlus Workstation. The path is:

\\DeltaV\ctl\ProgSerial\Ascii

Note that you will have to create the \Ascii subdirectory. The following files will be copied:

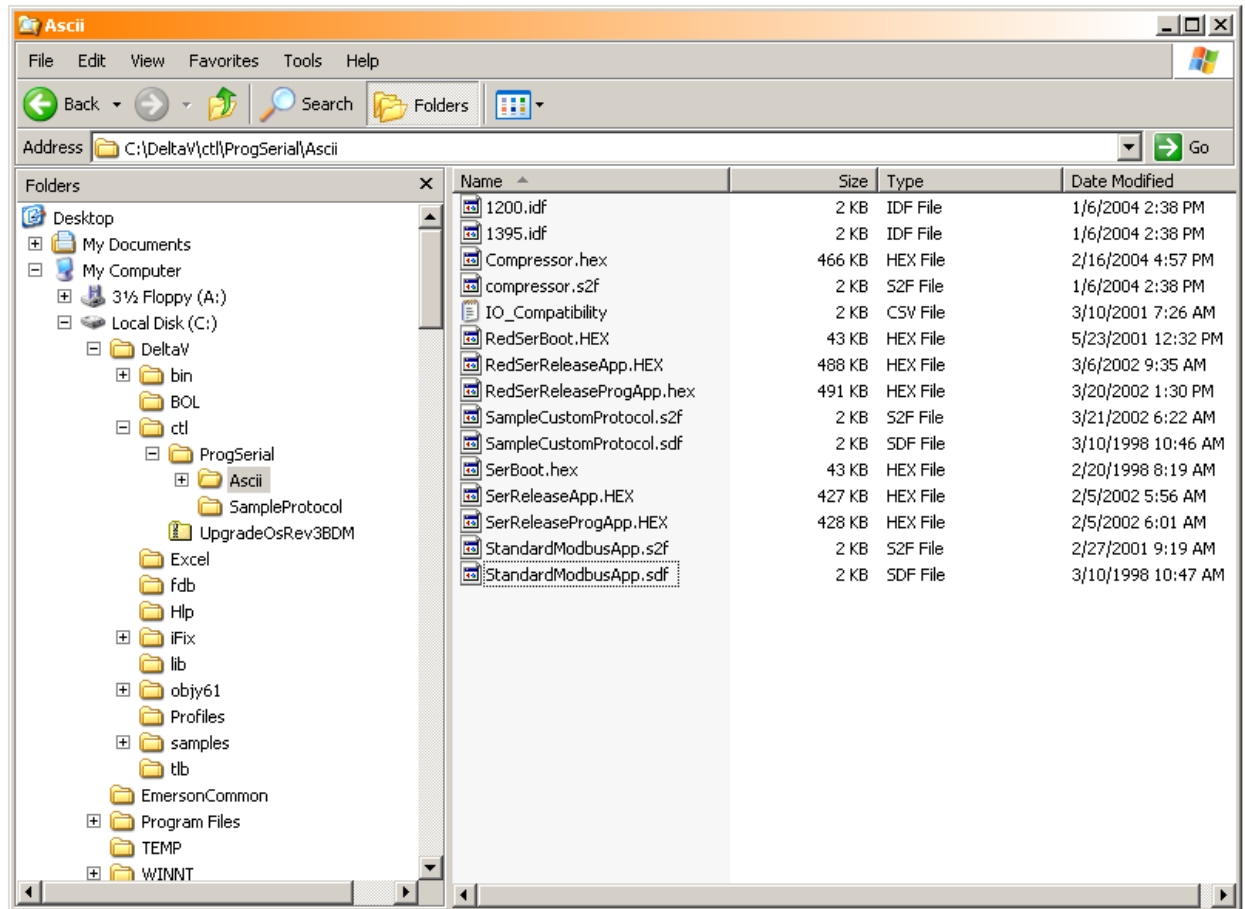

After copy completion, you are ready to program (or upgrade) the Programmable Serial Card with the supplied custom driver software. The steps are as follows:

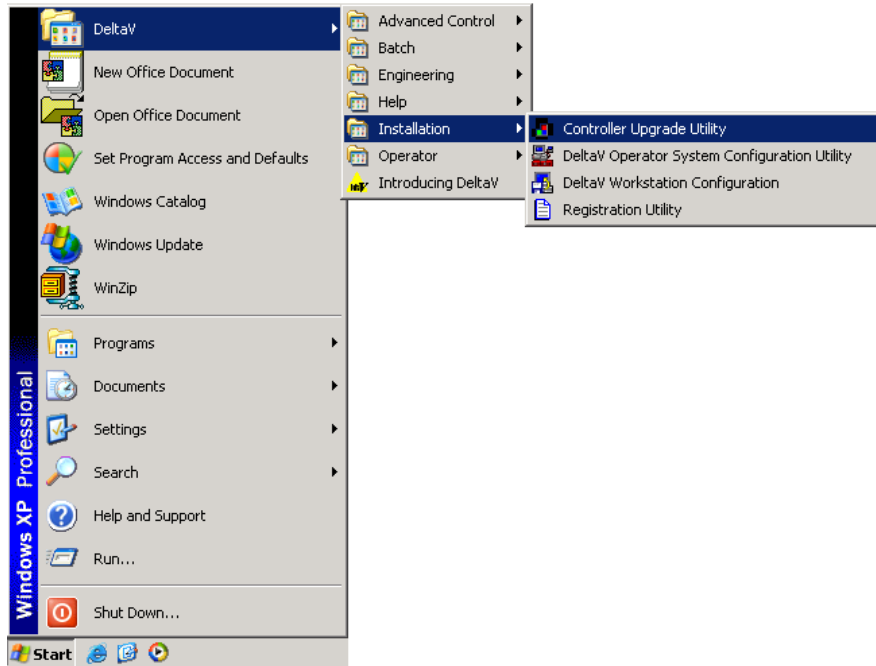

1. Click on the Start button and select DeltaV-> Installation-> Controller Upgrade Utility as shown below, and the following dialog will appear:

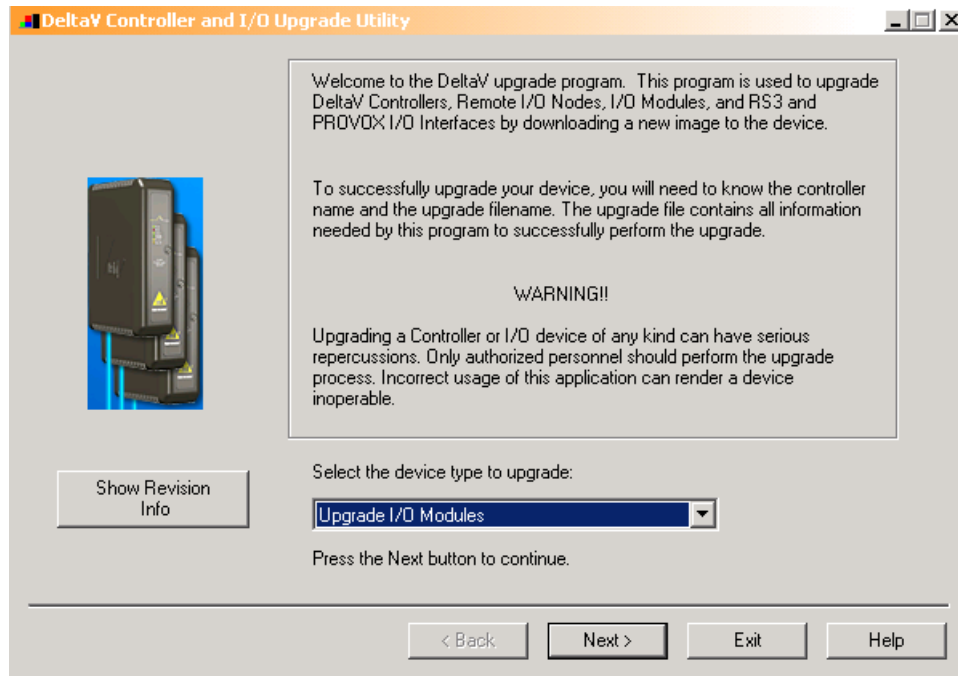

2. Choose Upgrade I/O Modules from the drop down menu and click Next.

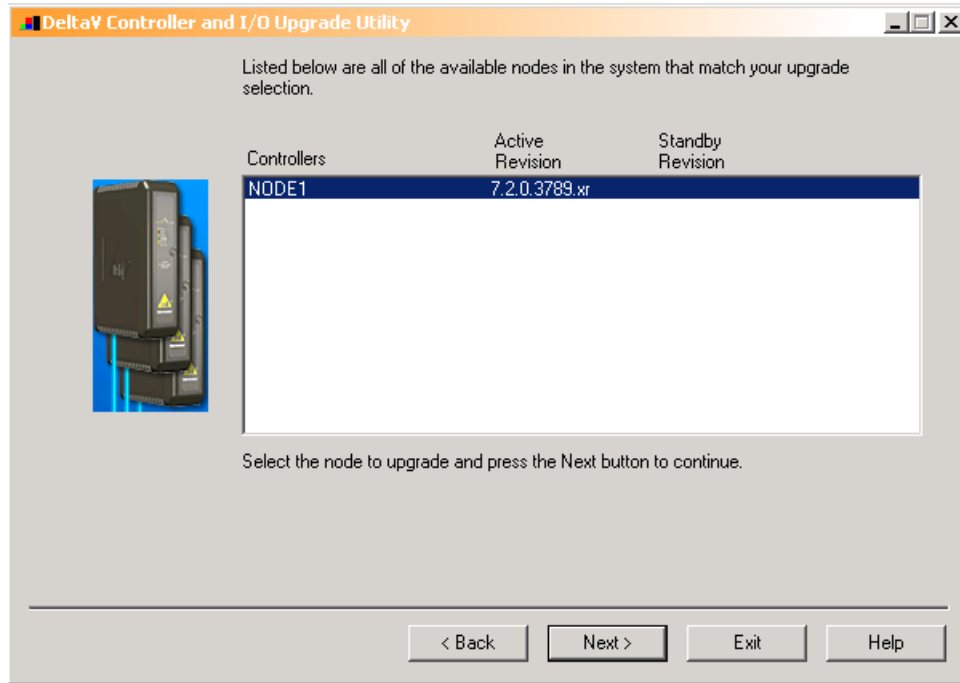

3. The above dialog will appear, listing all the available Controllers in your network. From this dialog, select the appropriate Controller and then Click Next.

4. The following dialog will appear, listing all the I/O modules in your selected Controller. The shown list of I/O modules is an example only. Your list will be different.

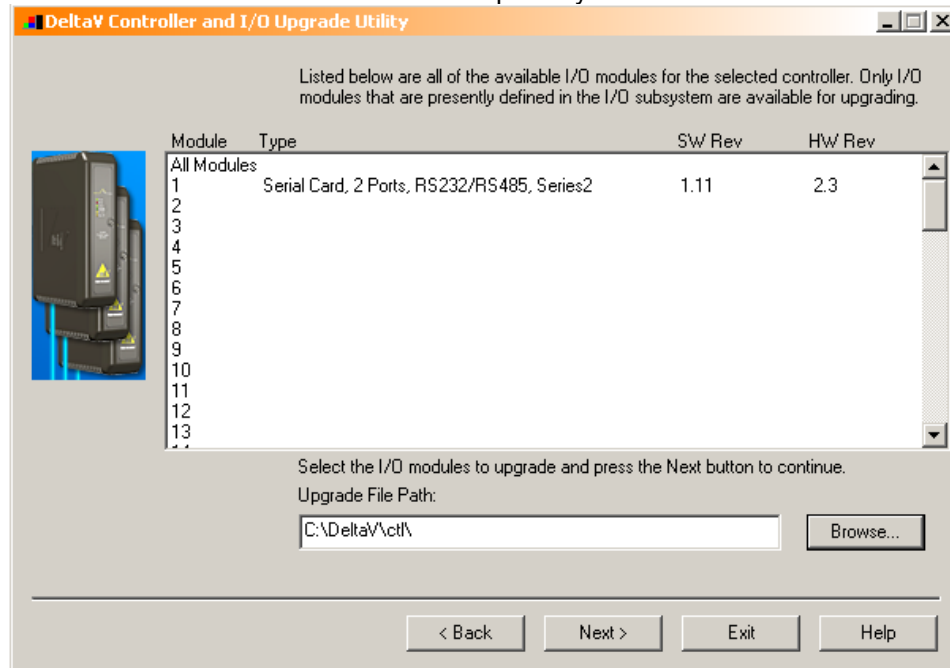

Note: The first time a standard Serial card is upgraded to the ASCII Compressor Driver, the dialog shown above will appear. When upgrading an existing

Programmable Serial Card, the dialog shown below will appear. If you are upgrading a Programmable Serial Card, skip Steps 4, 5 and 6, and go to Step 7.

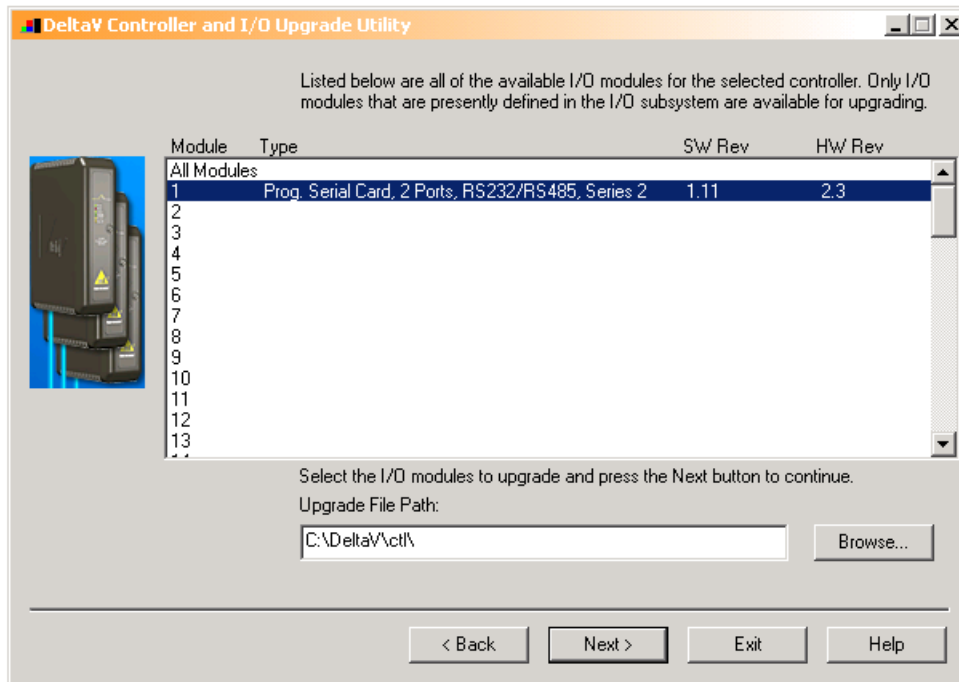

5. Click the Browse button and select the DeltaV path as shown below, and then click Ok. Note that the disk drive could be C or D.

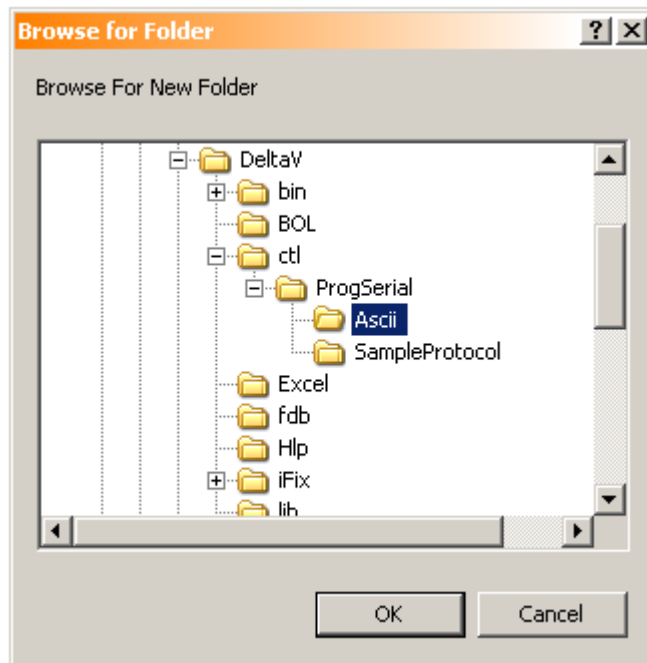



6. Select the I/O module again and then click Next. Go to Step 9.

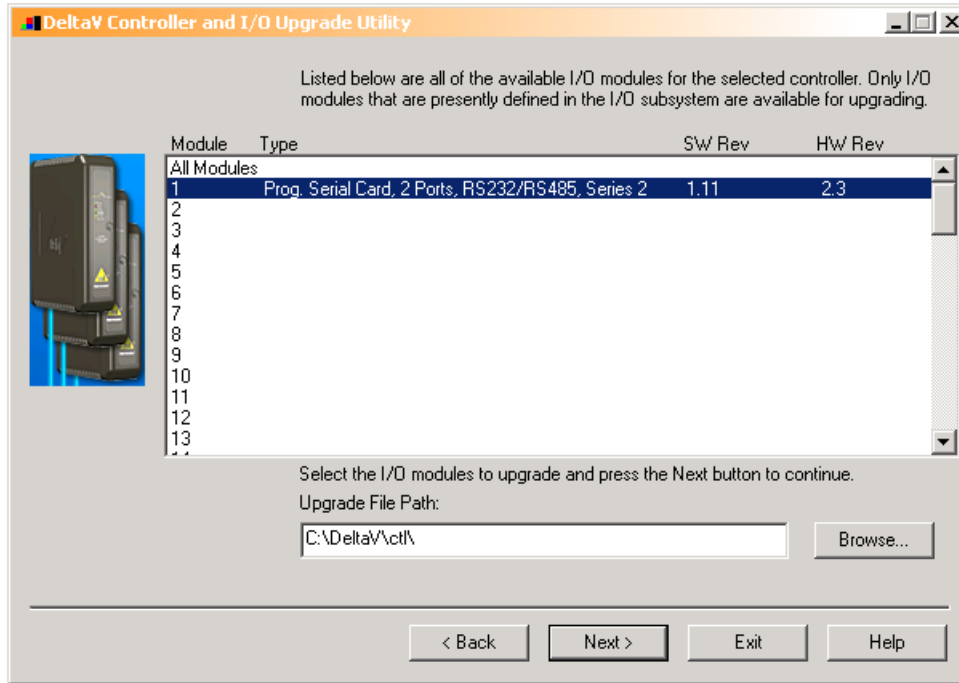

7. If you are upgrading an existing Programmable Serial Card, the dialog will be as shown above. From this dialog, select the Programmable Serial Card I/O Module in the list. This will give you a dialog from which you will select the file path to where the driver software is located. This path will be:

\\DeltaVctl\ProgSerial\Ascii

Once you are in the specified directory, you will need to select the following file:

Compressor.S2F

This is shown in the following dialog.

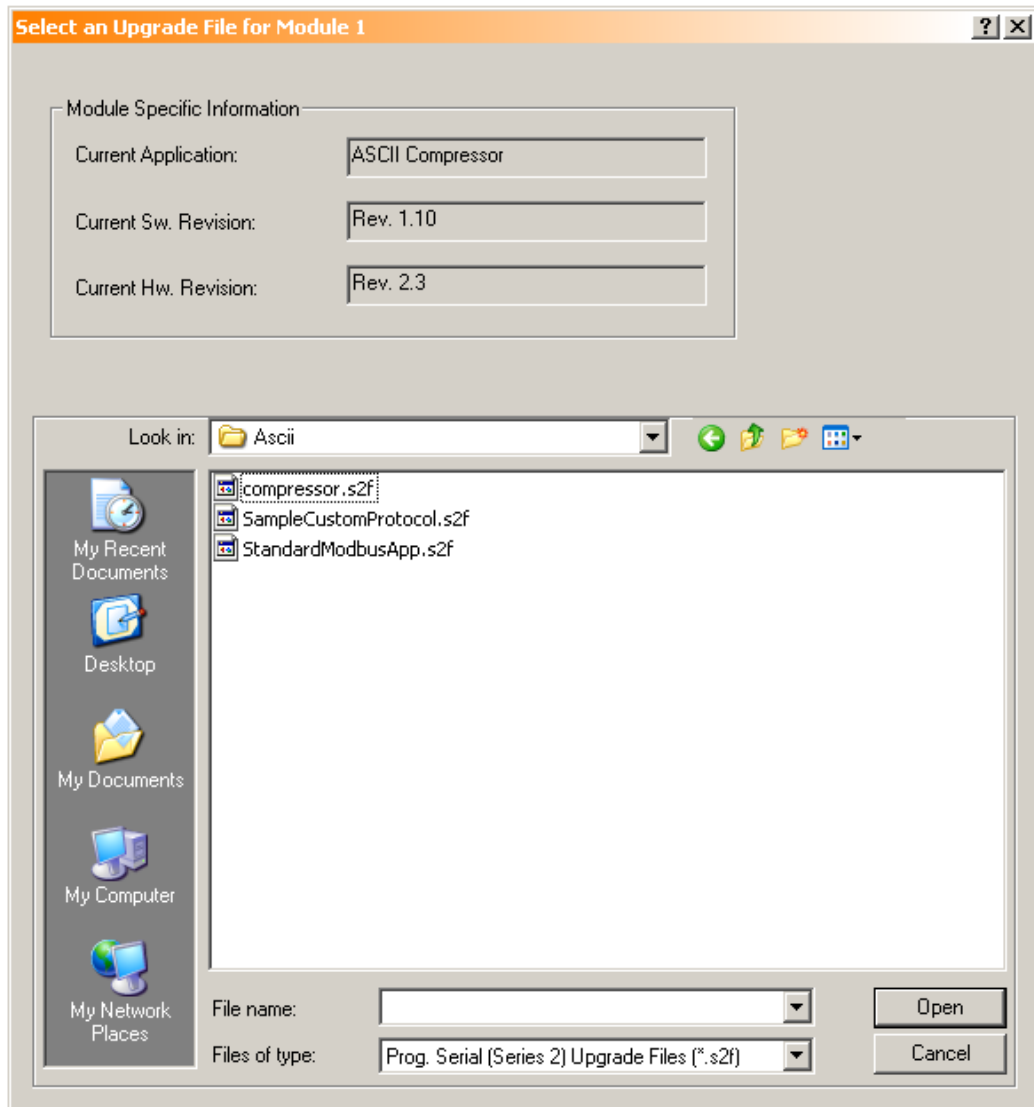

8. After selecting the .S2F file, Click on Open. This dialog will close and you will be back to the following:

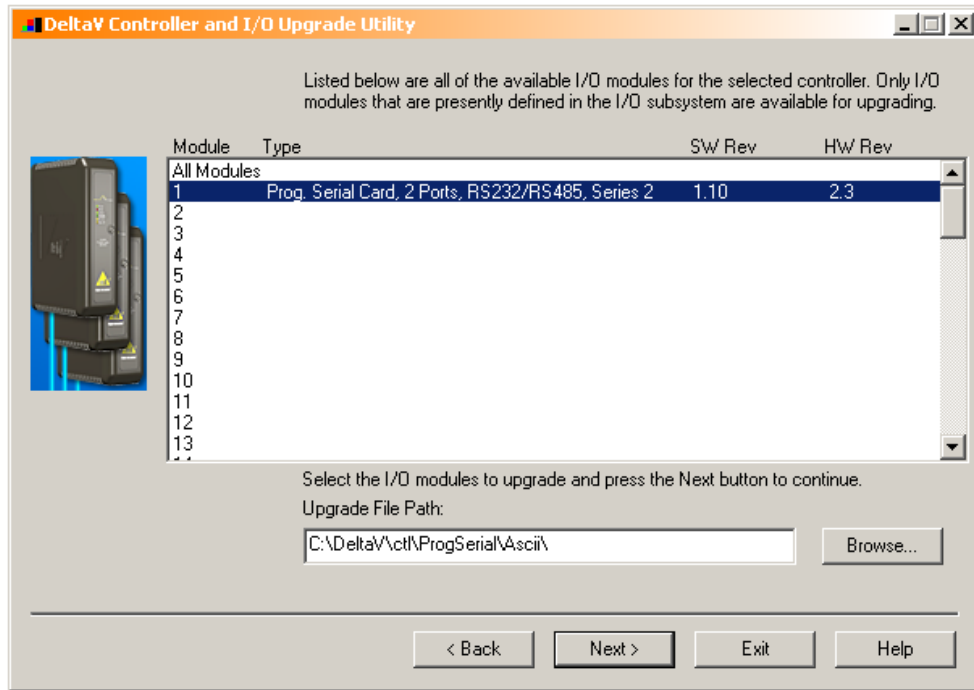

8. In this dialog, Click Next again. You will get the following dialog, confirming the Controller and I/O Module to program.

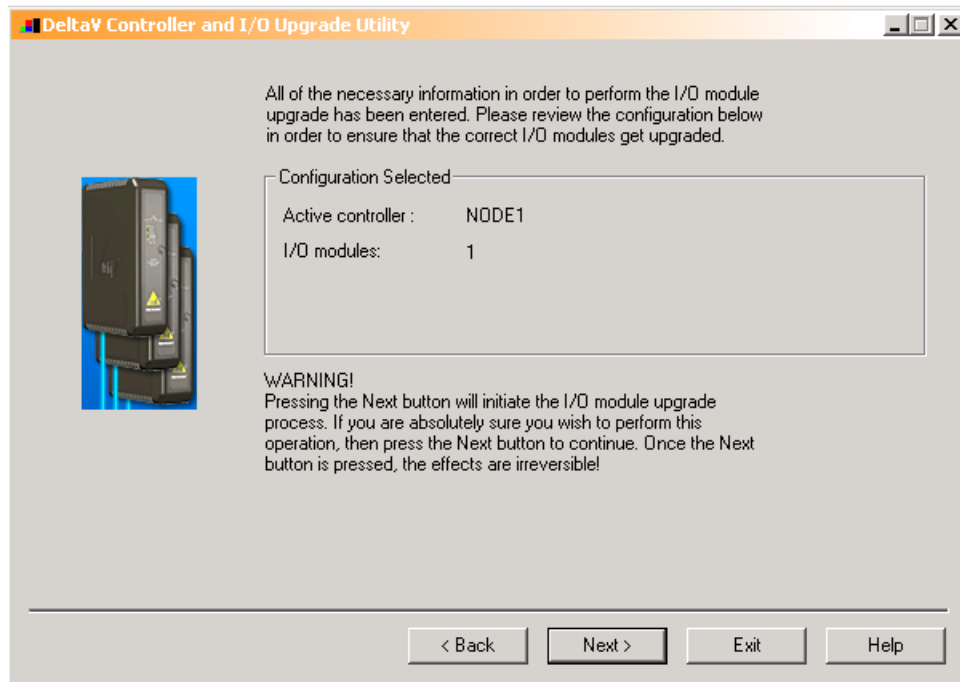

10. Click Next and the I/O Module upgrade process will begin. After completion, you will receive the following dialog, indicating success.

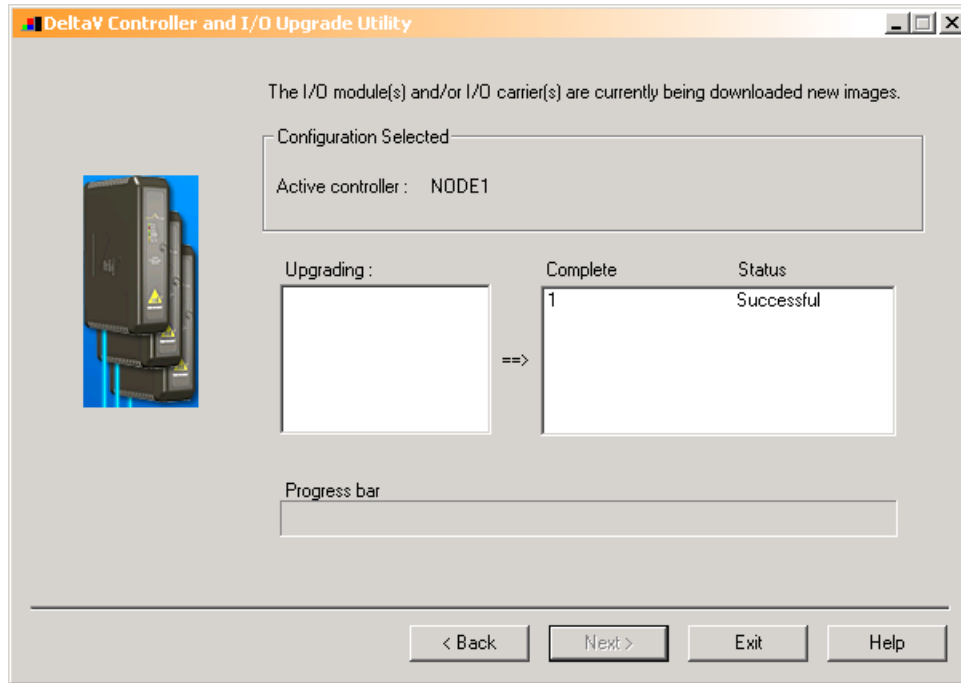

11. This completes the I/O Module upgrade process.



4 CONFIGURATION INFORMATION

For this application, a fixed configuration format is proposed. The DeltaV Explorer view of a configuration containing a Serial Card will be as follows, where C1 has a card type of Serial Card, P01 and P02 are the ports on the card, DEVXX are pseudo devices attached to the ports, and DSXX are configured Datasets for each device:

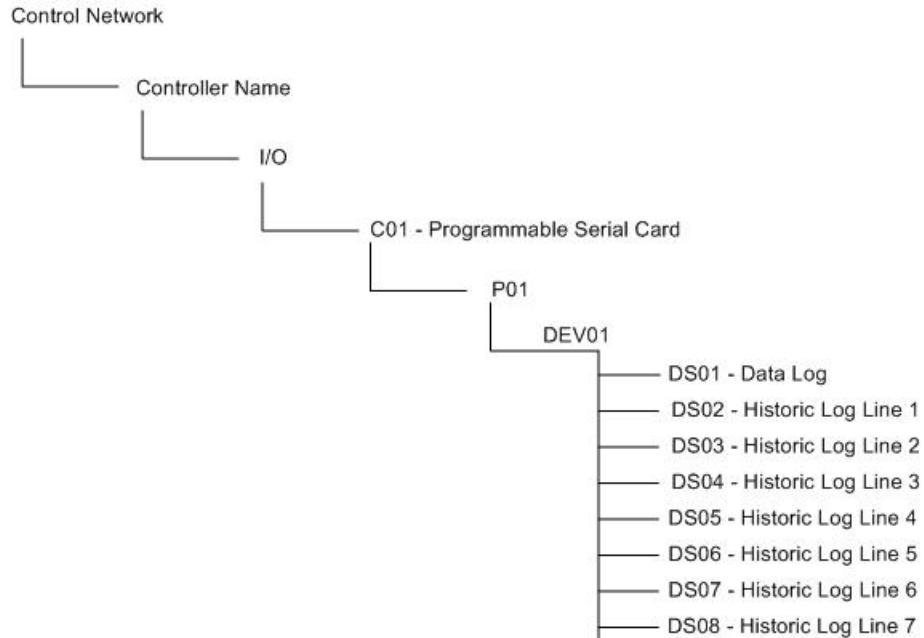



Specifically, each port PXX will be configured with up to 1 device, e.g., DEV01. Each device will be configured with 8 datasets, DS01 – DS08 as shown below.

Table 3

Port	Devices	Dataset	Mode	Type and Number of Values	Description
P01					
	DEV01				
		DS01	Input	16-bit integer 14	Data Log
		DS02	Input	16-bit integer 14	Historic Log 1
		DS03	Input	16-bit integer 14	Historic Log 2
		DS04	Input	16-bit integer 14	Historic Log 3
		DS05	Input	16-bit integer 14	Historic Log 4
		DS06	Input	16-bit integer 14	Historic Log 5
		DS07	Input	16-bit integer 14	Historic Log 6
		DS08	Input	16-bit integer 14	Historic Log 7

*See section 4.3.3



Registers of the data log dataset will be configured and used as follows:

Table 4

Register	Channel	Description
R1		
R2	Channel 1	
R3	Channel 2	
R4	Channel 3	
R5	Channel 4	
R6	Channel 5	.
R7	Channel 6	
R8	Channel 7	
R9	Channel 8	
R10		Mean PT Exit Temp
R11		Exhaust Tem
R12		Gas Generator Speed %
R13		Power Turbine Speed %
R14		Fuel Valve Demand (deg)



4.1 Port Configuration

First, enable the port. Then click on the Advanced Tab and Slave mode. Master is not support. Specify the retry count, message timeout value in milliseconds, and message delay time. In most cases, you can leave these at their default values. Next, click on the Communications Tab and specify the Port type. The Port type will be RS-232. In general, RS-232 will be used for most printer/logging devices. Lastly, select the Baud rate, Parity, Data bits and Stop bits parameters; these must match the external device settings.

4.2 Device Configuration

Specify devices, as shown above. There will be one device under each port.

4.3 Dataset Configuration

Datasets contain the actual string data being printed.

4.3.1 Data Direction:

The Data Direction for dataset should always be defined as Input.

4.3.2 Output Mode:

Output mode and Readback items are not used. These should be left as default.

4.3.3 DeltaV Data Type:

All datasets will be configured as type 16 bit integer with status.

4.3.4 DeviceDataType

All Device Data Type values will be configured as 0.

4.3.5 Data Start Address and Number of Values

The Start Address for each dataset should be configured as shown below:

Table 6

Port	Dataset #	Start Address	Number Of Values	Type
1	1	0	14	16-bit Integer
1	2	100	14	16-bit Integer
1	3	200	14	16-bit Integer
1	4	300	14	16-bit Integer
1	5	400	14	16-bit Integer
1	6	500	14	16-bit Integer
1	7	600	14	16-bit Integer
1	8	700	14	16-bit Integer



5 Operational Check

5.1 Scope

The following sections provide some assistance to ensure the interface is working properly.

5.2 Verify Hardware and Software Version Number

The user can verify that the ASCII compressor driver has been installed using the DeltaV Diagnostics tool. The Diagnostics tool will show the Hardware Revision No. (HwRev) and the Software Revision No. (SwRev).

To begin the DeltaV Diagnostic tool select Start-> DeltaV-> Operator-> Diagnostics. In the Diagnostics tool expand the Controller, I/O and then double click on the Programmable Serial Interface Card that has the driver installed.

The following information will be displayed:

:	:	:
HwRev	Hardware Revision	1.11 (or later)
SwRev	Software Revision	2.3 (or later)

5.3 Verify Configuration

- Verify port configuration: The serial port must be enabled. User needs to make sure communication settings such as baud rate, parity, and number of data bits match the field device settings.
- Verify dataset configuration: The datasets configured must be as shown above.

5.4 Verify I/O Communication With Control Studio

User can create I/O modules in the control studio to verify correct values are being written out. An example module is shipped with the distribution. This module shows methods for writing text to the datasets and also how to handle time.

5.5 Using Diagnostics

- Verify PSIC communication: Select the PSIC on Diagnostics and press the right mouse button. Select Display Real -Time Statistics from the drop down menu. If the Programmable Serial Interface Card is functioning then the user will see the Valid Responses counter and the Async and/or Sync Transactions counters incrementing. There will not be any error counting up.



- Verify port statistics: Select the Port on the Programmable Serial Interface Card and press the right mouse button. Then select Display Port Statistics form the drop down menu. Verify that the port communications statistics are being displayed properly and are counting as expected for the protocol's functionality.
- Verify dataset values: Select a dataset and press the right mouse button. Select View Dataset Registers from the Drop down window. Verify that the dataset values are displayed as expected.

5.6 LED Indication

The Yellow LED for the port should be on solid when all communications on that port are valid. The Yellow LED should be blinking if there is some valid communications and some communications with errors on that port. The Yellow LED should be OFF if there are no valid communications on that port.



6 DeltaV–Field Device Electrical Interface

The electrical interface between DeltaV and field devices conforms to the RS-232 and RS-422/485 standards.

Each PSIC has 2 ports, which function independently. The distance between the serial card and the field device can be as much as 5000 feet, per the RS-422/485 standard. When using RS-232, the distance is limited to 50 feet. Section 6.1 shows the pin assignments for the PSIC serial terminal block.

6.1 Pin Assignments for DeltaV PSIC

RS-232 Standard

Terminal Number	Signal Description
1	Port 1 - Isolated Ground (GND)
2	Unused
3	Port 1 – Transmit Data (TxD)
4	Unused
5	Port 1 – Receive Data (RxD)
6	Unused
7	Port 1 – Data Terminal Ready (DTR)
8	Port 1 – Data Set Ready (DSR)
9	Port 2 - Isolated Ground (GND)
10	Unused
11	Port 2 – Transmit Data (TxD)
12	Unused
13	Port 2 – Receive Data (RxD)
14	Unused
15	Port 2 – Data Terminal Ready (DTR)
16	Port 1 – Data Set Ready (DSR)



RS-422/485 Half Duplex Standard

Terminal Number	Signal Description
1	Port 1 - Isolated Ground (GND)
2	Port 1 - Data +
3	Unused
4	Port 1 - Data -
5	Unused
6	Unused
7	Unused
8	Unused
9	Port 2 - Isolated Ground (GND)
10	Port 2 - Data +
11	Unused
12	Port 2 - Data -
13	Unused
14	Unused
15	Unused
16	Unused

RS-422/485 Full Duplex Standard

Terminal Number	Signal Description
1	Port 1 - Isolated Ground (GND)
2	Port 1 - TxD +
3	Unused
4	Port 1 - TxD -
5	Unused
6	Port 1 - RxD +
7	Unused
8	Port 1 - RxD -
9	Port 2 - Isolated Ground (GND)
10	Port 2 - TxD +
11	Unused
12	Port 2 - TxD -
13	Unused
14	Port 2 - RxD +
15	Unused
16	Port 2 - RxD -



6.2 Wiring Connections

In general, the figure below shows the connections between the Field Device and the PSIC termination block. In some cases, RxD and TxD signals need to be swapped to create a NULL cable. This can be done easily at the PSIC termination block.

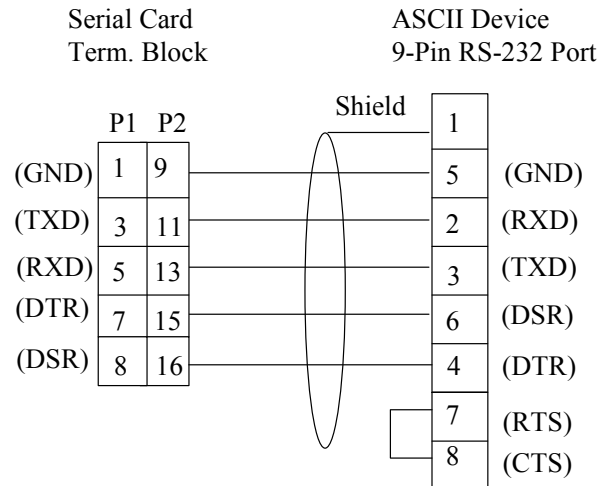
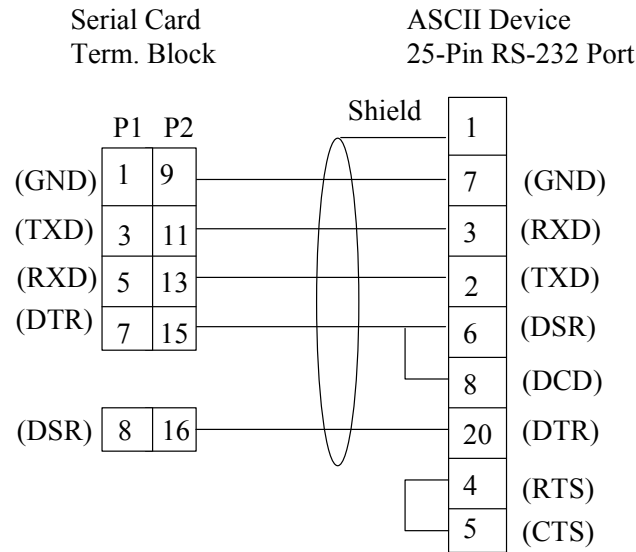



Serial Card
Term. Block

ASCII Device
RS-422/485 Full Duplex

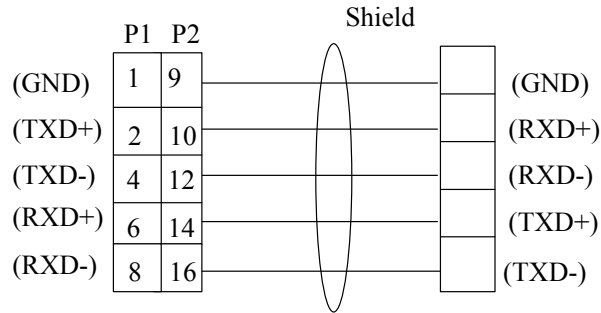

Serial Card
Term. Block

ASCII Device
RS-422/485 Half Duplex

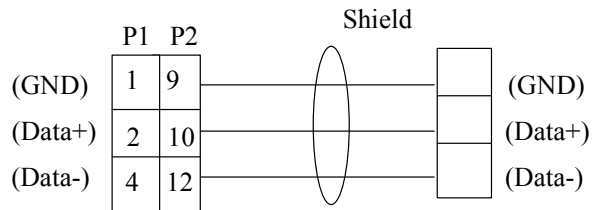



M Y N A H™

POWERFUL SOLUTIONS FOR DIGITAL PLANTS

7 Technical Support

For technical support or to report a defect, please give Mynah Technologies a call at (636) 681-1555. If a defect is discovered, please document it in as much detail as possible and then fax your report to us at (636) 681-1660.

For Product functionality questions, ask for the people in the following order:

1. David Story
2. Tony Kerr

For Commercial issues, ask for people in the following order:

1. Martin Berutti
2. Jane Wagner

You can also send us your questions via e-mail. Our address is:

support@mynah.com

Thank you for using DeltaV.