



**M Y N A H<sup>SM</sup>**

**AccuSort MiniX Driver for DeltaV  
Programmable Serial Interface Card  
Series 2**

**USER MANUAL**

**Rev. P1.12**

**November 3, 2005**

DeltaV is a trademark of Emerson Process Management © Emerson Process Management 1998, 1999. All rights reserved.

Printed in the U.S.A.

While this information is presented in good faith and believed to be accurate, MYNAH Technologies does not guarantee satisfactory results from reliance upon such information. *Nothing contained herein is to be construed as a warranty or guarantee, express or implied, regarding the performance, merchantability, fitness or any other matter with respect to the products*, nor as a recommendation to use any product or process in conflict with any patent. MYNAH Technologies reserves the right, without notice, to alter or improve the designs or specifications of the products described herein.



# 1 INTRODUCTION

## 1.1 Scope

This document is the User Manual for an AccuSort MiniX serial communication driver firmware for the Emerson DeltaV Control System; it provides information required to install, configure, and maintain the driver firmware on the DeltaV Series 2 Programmable Serial Interface Card (PSIC). The reader should be familiar with Emerson’s DeltaV controller system and the scanner equipment.

The section *Document Format* briefly describes the contents of each section of this manual. *System Specifications* outlines hardware and software requirements for the Driver (P1.12) firmware. *Related Documents* lists other documents used to prepare this manual.

## 1.2 Document Format

This document is organized as follows:

<b>Introduction</b>	Describes the scope and purpose of this document.
<b>Theory of Operation</b>	Provides a general functional overview of the Driver.
<b>Downloading Firmware</b>	Describes downloading procedures for the driver firmware on to the DeltaV PSIC.
<b>PSIC Configuration</b>	Describes procedures and guidelines for configuring the DeltaV PSIC.
<b>Driver Communications</b>	Describes how DeltaV PSIC dataset registers are used for bar code data.
<b>Operational Check</b>	Provides tips and assistance to ensure PSIC is properly setup and configured.
<b>Electrical Interface</b>	Describes the electrical interface between DeltaV and the bar code devices. Also describes the pin assignments for RS-232 communications.
<b>Technical Support</b>	Describes who to call if you need assistance.



### 1.3 System Specifications

The following table lists the minimum hardware requirements for the Driver:

**Table 1: System Specifications**

<b>Firmware</b>	Driver Firmware (P1.12)
<b>Protocol Compatibility</b>	Scanner data as ASCII text.
<b>Software Requirements</b>	DeltaV System Software (Release 4.2 or later) installed on a hardware-appropriate Windows NT workstation configured as a ProPlus for DeltaV Serial Interface Port License (VE4102)
<b>Minimum Hardware Requirements</b>	FRSI DeltaV PSIC Hardware PN: 12P2506X022 FRSI DeltaV M3, M5, MD or Series 2 MD Controller, Power Supply and 2 wide controller carrier FRSI 8 wide I/O card carrier Scanner or other ASCII devices



## 2 THEORY OF OPERATION

As part of the serial interface port license, a standard Modbus protocol is installed on the DeltaV PSIC prior to customization. The PSIC needs to be flash upgraded from the Modbus protocol to the ASCII Reader firmware before operation.

The RS-232 communication settings must be configured properly to ensure accurate communication between the PSIC and external devices. RS-422/485 may be used directly, or through a RS-422/485 to RS-232 converter.

This driver functions as a slave only. In slave mode, the PSIC waits for data to be received on its ports. The received data are reported to DeltaV via dataset registers.

A fixed architecture with a maximum of one (1) device under each PSIC port will be allowed. Each device will support a single dataset, where the received bar code information will be reported.

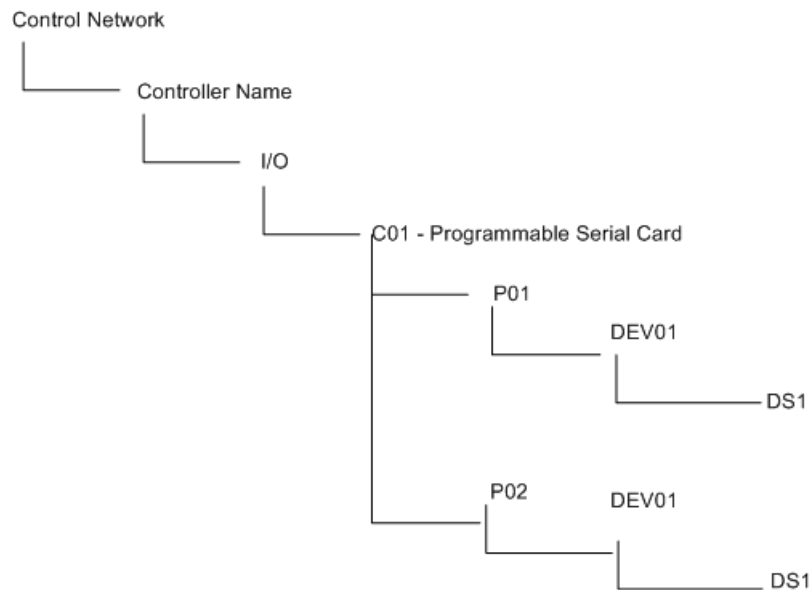

## 3 Downloading the firmware

The driver software is distributed on a CD. These files must be copied to the DeltaV directory (you must create the directory first) on your ProPlus Workstation. The path is:

**\\DeltaV\ctl\ProgSerial\AccuSort MiniX**

The following shows a completed copy operation:

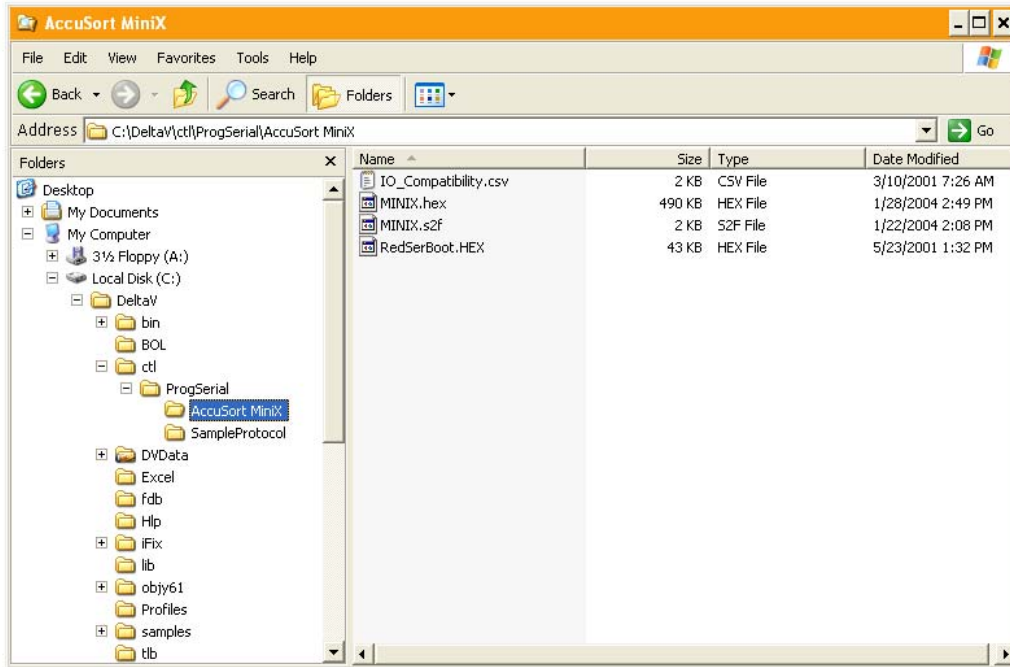

After copy completion, you are ready to program (or upgrade) the Programmable Serial Card with the supplied custom driver software. The steps are as follows:



1. Click on the Start button and select DeltaV, Installation, Controller Upgrade Utility as shown below.

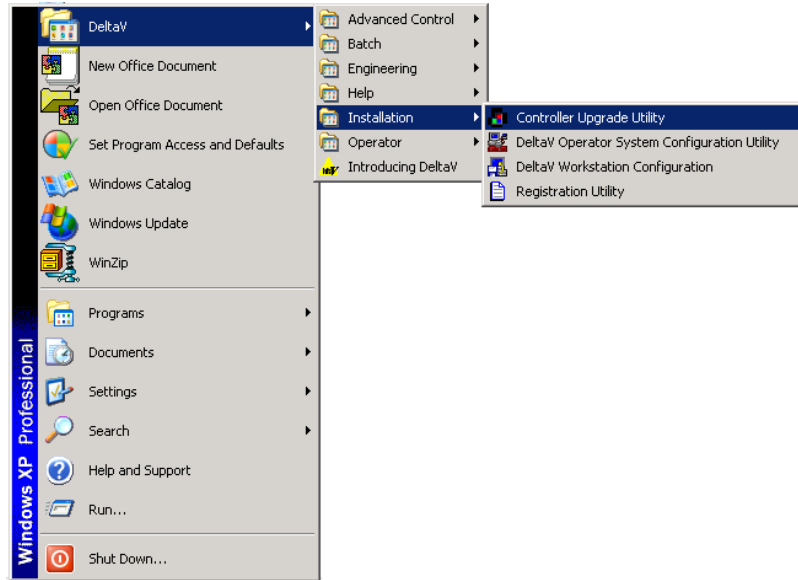

The following dialog will appear:

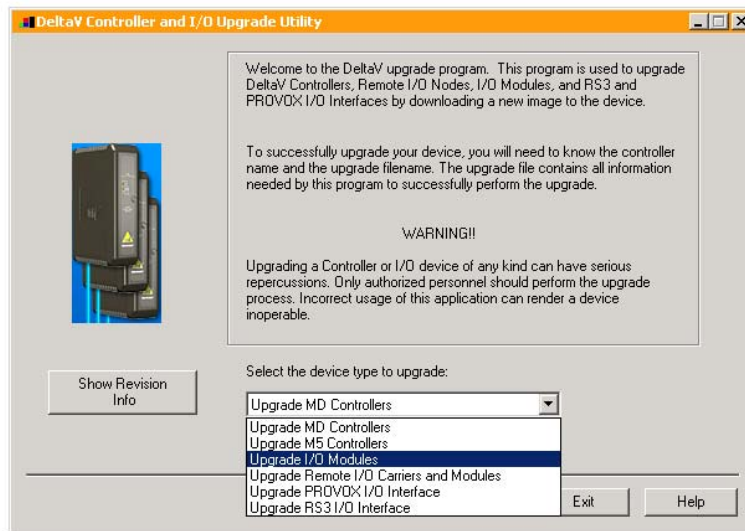

Click on the Upgrade I/O Modules radio button as shown, and then click Next.

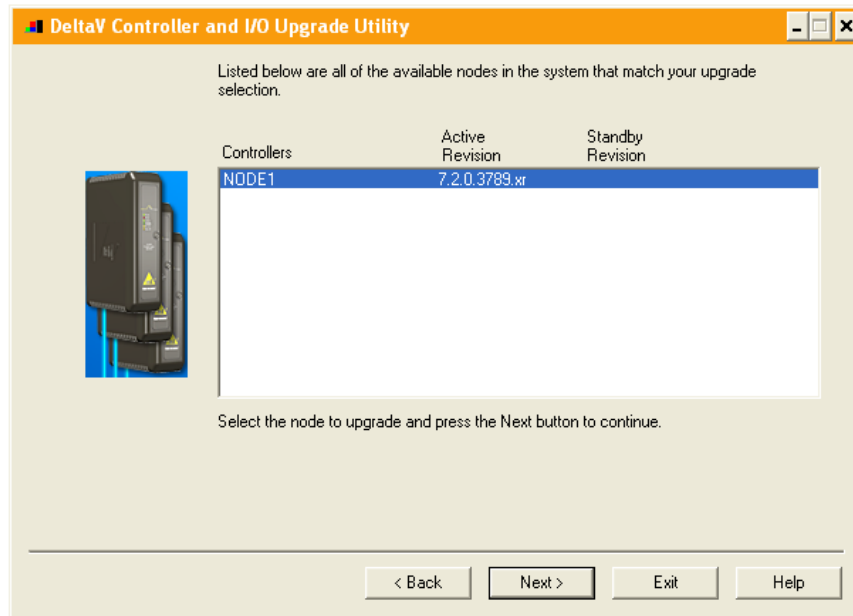

The above dialog will appear, listing all the available Controllers in your network. From this dialog, select the appropriate Controller and then Click Next

After you Click Next, the following dialog will appear, listing all the I/O modules in your selected Controller. The shown list of I/O modules is an example only. Your list will be different.

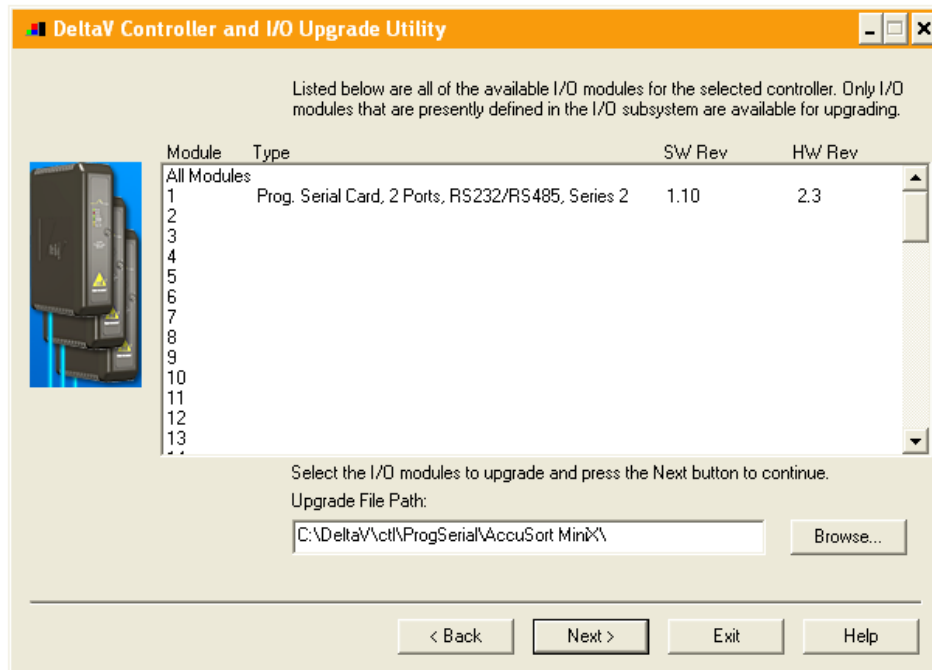

From this dialog, select the Programmable Serial Card I/O Module in the list. For example, we will select I/O Module 1. This will give you the following dialog, from



which you will select the file path to where the driver software is located. This will be:

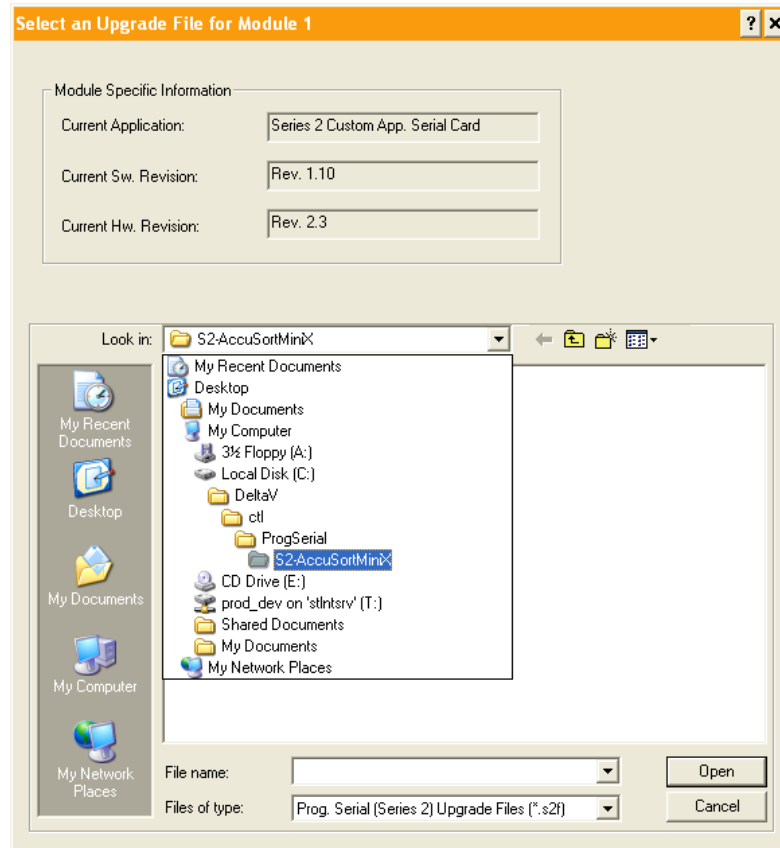

**\\DeltaVctl\ProgSerial\AccuSort MiniX**

Once you are in the specified directory, you will need to select the following file:

**MiniX.S2F**

After selecting the .S2Ffile, Click on Open. This dialog will close and you will be back to the following:

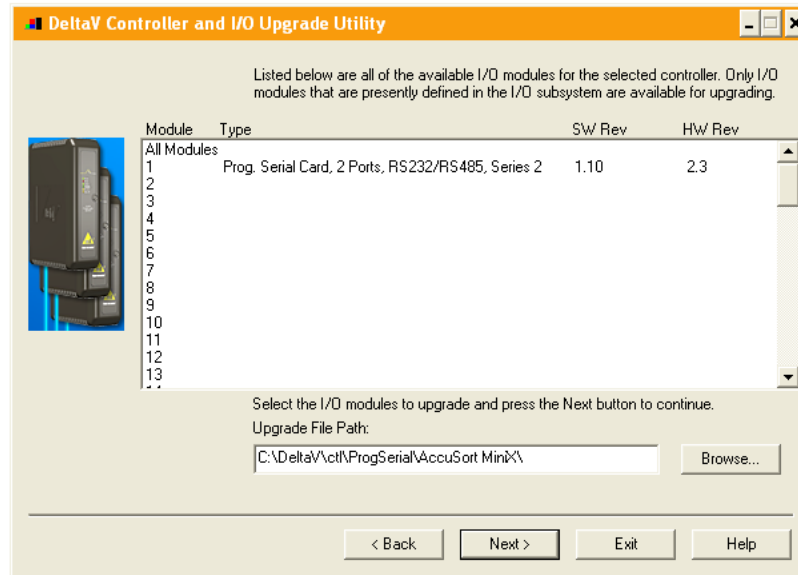

In this dialog, Click Next again. You will get the following dialog, confirming the Controller and I/O Module to program.

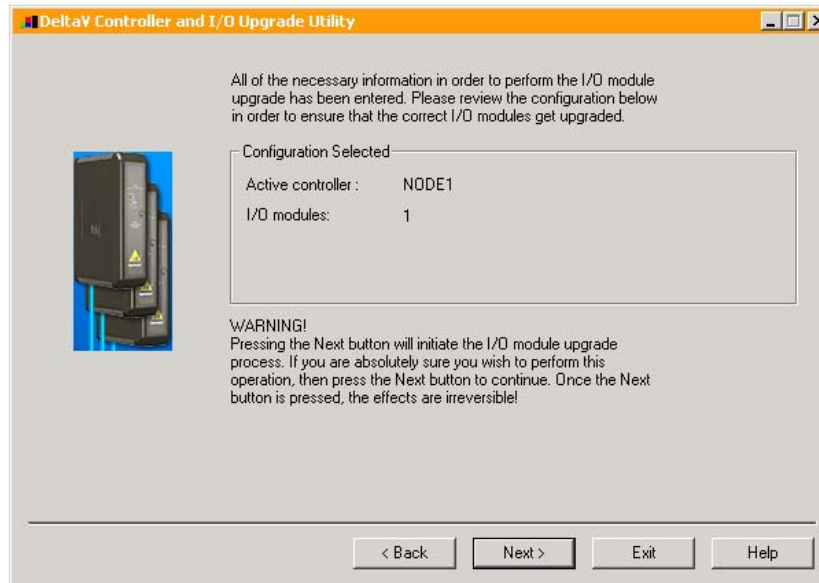

Click Next and the I/O Module upgrade process will begin. After completion, you will receive the following dialog, indicating success.

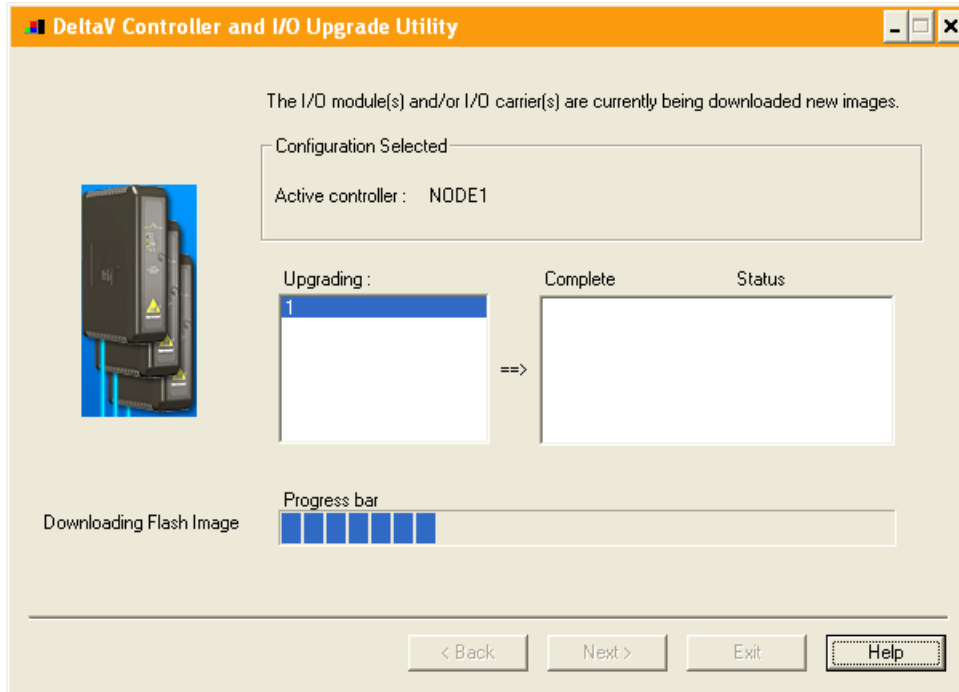

This completes the I/O Module upgrade process.



## 4 CONFIGURATION INFORMATION

This section describes the steps necessary to configure the DeltaV PSIC and the external device to obtain proper communication.

### 4.1 Device And Dataset Configuration

The following paragraphs discuss some attributes in the device and dataset configuration:

#### 4.1.1 Device Address:

You can configure a maximum of one (1) devices under each PSIC port. The driver does not use the device addresses, consequently these can be left at their default value.

#### 4.1.2 Output Mode:

All datasets will be of type Input.

#### 4.1.3 DeltaV Data Type:

The DeltaV Data Type can be configured as String, 8-Bit Int, 8-Bit Uint, 16-Bit Int, or 16-Bit Uint. Any other data types are not supported.

UPC codes read can be 9 or more characters long, with the default length of 9 characters. Users can change the expected UPC code length by specifying it in Special Data1. For example, to receive a 12 character UPC, configure a 12 in Special Data1.

By default, the data is expected to be numeric represented as ASCII bytes. The driver converts the ASCII bytes to numeric and then stores the data in the dataset registers. For example, for barcode data=000001088, the received data stream will be 0x30, 0x30, 0x30, 0x30, 0x30, 0x31, 0x30, 0x38, 0x38.

Non-numeric ASCII data bytes are also accepted. User can bypass the ASCII to numeric conversion of data bytes by setting Special Data2 to 1. For example, for barcode data=01234ABCD, the received data stream will be 0x30, 0x31, 0x32, 0x33, 0x34, 0x41, 0x42, 0x43, 0x44. With Special Data2 equal to 1, the data bytes are stored as received.

When using String type, the barcode data is stored in register 1 as a character string without any conversion. For example, for barcode = 000001088, the resulting data in DS1 will be R1 = 000001088.

When using 8-Bit, or 16-Bit datasets, each character of the barcode is stored in individual registers. For example, for barcode=000001088, the resulting data in DS1 will be as follows:

R1 = 0, R2 = 0, R3 = 0, R4 = 0, R5 = 0, R6 = 1, R7 = 0  
R8 = 8, R9 = 8



#### **4.1.4 DeviceDataType**

The driver does not use this value. Leave this value at its default setting of 0.

#### **4.1.4 Starting Address and Number of Values**

The starting address of the dataset should be configured as 0, and the number of values is the total length of the expected UPC code.

#### **4.1.5 Special Data**

Special Data1 and Special Data 2 registers are used as follows:

Special Data1 is the length of the expected UPC code. This value can be in the range  $> 9$  and  $\leq 100$ .

Special Data2 is a flag. When set to 1, the driver will bypass conversion of received ASCII data to numeric.



## **5 Operational Check**

### **5.1 Scope**

The following sections provide some assistance to ensure the interface is working properly.

### **5.2 Verify Hardware and Software Version Number**

The user can verify that the driver has been installed using the DeltaV Diagnostics tool. The Diagnostics tool will show the Hardware Revision No. (HwRev) and the Software Revision No. (SwRev).

To begin the DeltaV Diagnostic tool select Start-> DeltaV-> Operator-> Diagnostics. In the Diagnostics tool expand the Controller, I/O and then double click on the Programmable Serial Interface Card that has the driver installed.

The following information will be displayed:

:	:	:
HwRev	Hardware Revision	1.1 (or later)
SwRev	Software Revision	P1.0 (or later)

### **5.3 Verify Configuration**

- Verify port configuration: The serial port must be enabled. User needs to make sure communication settings such as baud rate, parity, and number of data bits match the external device settings.
- Verify dataset configuration: The datasets configured must be as shown above.

### **5.4 Verify I/O Communication With Control Studio**

User can create I/O modules in the control studio to verify correct values are read from the external device and the PSIC. For input data, the values should be changed in the external device and verified that the new data are correctly reported.

### **5.5 Using Diagnostics**

- Verify PSIC communication: Select the PSIC on Diagnostics and press the right mouse button. Select Display Real -Time Statistics from the drop down menu. If the Programmable Serial Interface Card is functioning then the user will see the Valid Responses counter and the Async and/or Sync Transactions counters incrementing. There will not be any error counting up.



- Verify port statistics: Select the Port on the Programmable Serial Interface Card and press the right mouse button. Then select Display Port Statistics from the drop down menu. Verify that the port communications statistics are being displayed properly and are counting as expected for the protocol's functionality.
- Verify dataset values: Select a dataset and press the right mouse button. Select View Dataset Registers from the Drop down window. Verify that the dataset values are displayed as expected.

## **5.6 LED Indication**

The Yellow LED for the port should be on solid when all communications on that port are valid. The Yellow LED should be blinking if there is some valid communications and some communications with errors on that port. The Yellow LED should be OFF if there are no valid communications on that port.



## 6 Electrical Interface

The electrical interface between DeltaV and external devices conforms to the RS-232, or RS-422/RS-485 protocol. The RS-232 cable connecting DeltaV PSIC and external devices should not exceed 50 feet as specified by the EIA standard for RS-232 protocol. Section 6.1 shows the pin assignments for the PSIC serial terminal block for RS-232 protocol. If using RS-422/RS-485, the distance is 4000 feet.

### 6.1 RS-232 Pin Assignments for DeltaV PSIC

Terminal Number	Signal Description
1	Port 1 - Isolated Ground (GND)
2	Unused
3	Port 1 - Transmit Data (TXD)
4	Unused
5	Port 1 - Receive Data (RXD)
6	Unused
7	Port 1 - Data Terminal Ready (DTR)
8	Port 1 - Dataset Ready (DSR)
9	Port 2 - Isolated Ground (GND)
10	Unused
11	Port 2 - Transmit Data (TXD)
12	Unused
13	Port 2 - Receive Data (RXD)
14	Unused
15	Port 2 - Data Terminal Ready (DTR)
16	Port 2 - Dataset Ready (DSR)

### 6.2 Wiring Connections for RS-232 Communications

Five terminals need to be connected between the PSIC and the external device port. Pins 3 (TXD) and 5 (RXD) need to be crossed so that the external device TXD is connected to PSIC RXD, and the external device RXD is connected to PSIC TXD. Pins 7 (DTR) and 8 (DSR) also need to be crossed in the same manner between the PSIC and the external device. Alternatively, you can jumper DTR and DSR on the PSIC terminal block. In all cases, the GND signal goes through, i.e., connect terminal block screw 1 to GND on the external device. If the external device port is 9-pin D-shell, then GND is pin 5. If the port is 25-pin D-Shell, then the GND is pin 7.



**M Y N A H™**

Powerful Solutions for Digital Plants

## **7 Technical Support**

For technical support or to report a defect, please give MYNAH Technologies a call at (636) 681-1555. If a defect is discovered, please document it in as much detail as possible and then fax your report to us at (636) 681-1660.

You can also send us your questions via e-mail. Our address is:

[support@mynah.com](mailto:support@mynah.com)

Thank you for using DeltaV.