



M Y N A HSM

**GE 90-70 PLC
Programmable Serial Interface Card
Series 2**

USER MANUAL

Rev. P1.10

May 15, 2004

DeltaV is a trademark of Emerson Process Management, Inc © Emerson Process Management, Inc. 1998, 1999.
All rights reserved.

Printed in the U.S.A.

While this information is presented in good faith and believed to be accurate, MYNAH Technologies does not guarantee satisfactory results from reliance upon such information. *Nothing contained herein is to be construed as a warranty or guarantee, express or implied, regarding the performance, merchantability, fitness or any other matter with respect to the products*, nor as a recommendation to use any product or process in conflict with any patent. MYNAH Technologies reserves the right, without notice, to alter or improve the designs or specifications of the products described herein.



1 INTRODUCTION

1.1 Scope

This document is the User Manual for the GE 90-70 PLC driver firmware for the Emerson Process Management (EPM) DeltaV Control System; it provides information required to install, configure, and maintain the driver firmware on the DeltaV Series 2 Programmable Serial Interface Card (PSIC). The reader should be familiar with EPM’s DeltaV PSIC and connected GE 90-70 PLC devices.

The section *Document Format* briefly describes the contents of each section of this manual. *System Specifications* outlines hardware and software requirements for the GE 90-70 PLC Driver (P1.10) firmware. This driver is not available for Series 1 serial cards.

1.2 Document Format

This document is organized as follows:

Table 1

Introduction	Describes the scope and purpose of this document.
Theory of Operation	Provides a general functional overview of the GE 90-70 PLC Driver.
Downloading Firmware	Describes downloading procedures for the GE 90-70 PLC Driver firmware on to the DeltaV PSIC.
Configuration Information	Describes procedures and guidelines for configuring the DeltaV PSIC.
Operational Check	Provides tips and assistance to ensure PSIC is properly setup and configured.
DeltaV–Field Device Electrical Interface	Describes the electrical interface between DeltaV and the GE 90-70 PLC device. Also describes the cable pin assignments for RS-232 and RS-422/485 communications.
Technical Support	Describes who to call if you need assistance.
Example	Describes how to configure a device with input and output datasets.



1.3 System Specifications

The following table lists the minimum system requirements for the GE 90-70 PLC Driver:

Table 2

Firmware	GE 90-70 PLC Driver Firmware (P1.10)
Protocol Compatibility	Series 90 - PLC Serial Communications Users Manual (gfk0582d)
Software Requirements	DeltaV System Software (Release 6.3.2 or later) installed on a hardware-appropriate Windows NT or later workstation configured as a ProfessionalPlus for DeltaV Serial Interface Port License (VE4102)
Minimum DeltaV Hardware Requirements	FRSI DeltaV Serial Interface Series 2, Hardware PN: 12P2506X022 FRSI DeltaV M3, M5, MD or Series 2 MD Controller, Power Supply and 2 wide controller carrier FRSI 8 wide I/O card carrier

2 THEORY OF OPERATION

The Programmable Serial Interface Card (PSIC) has 2 ports which can be configured for RS-232, RS-422/RS-485 Half Duplex or RS-422/RS-485 Full Duplex communications with external devices. For communications with the GE 90-70 PLC devices, any mode may be used.

The DeltaV Serial Card Driver functionality will be as follows.

1. The driver will be flashed into the PSIC.
2. The driver will run in Master mode only and be responsible for sending commands to the GE90-70 units.

The following shows PSIC Simplex and Redundant connectivity options with GE 90-70 PLC devices:

Option 1: Simplex

Simplex Scenario

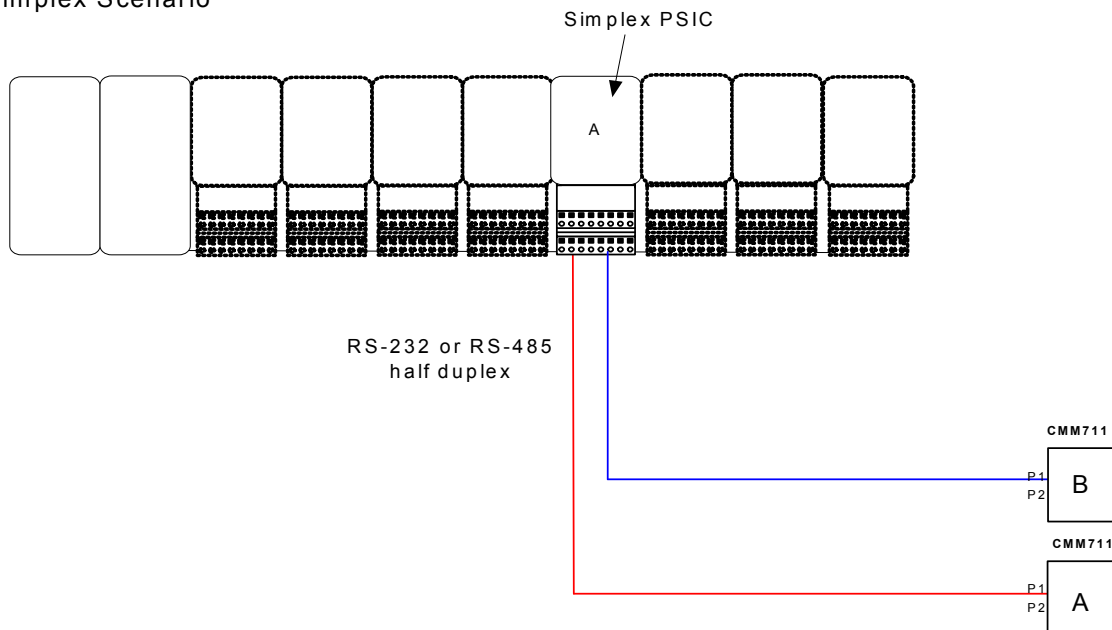

Notes:

1. PSIC Port 1 (Red) communicates with Port 1 of the CMM A.
2. PSIC Port 2 (Blue) communicates with Port 1 of the CMM B.

Option 2: Redundant Scenario 1

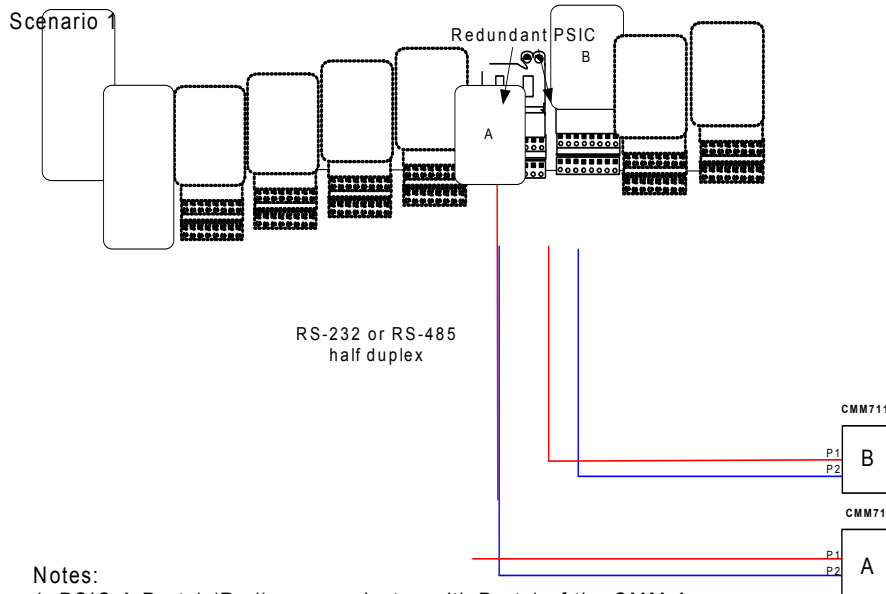

Notes:

1. PSIC A Port 1 (Red) communicates with Port 1 of the CMM A.
2. PSIC A Port 2 (Blue) communicates with Port 2 of the CMM A.
3. PSIC B Port 1 (Red) communicates with Port 1 of CMM B. This communication is only a Ping to keep the connection hot.
4. PSIC B Port 2 (Blue) communicates with Port 2 of CMM B. This communication is only a Ping to keep the connection hot.
5. If there is a communication failure on PSIC A (either port), then communications automatically switch to PSIC B, or vice versa.
6. With this mechanism, if there is any wiring problem with a secondary PSIC, it will be known by DeltaV.

Option 3: Redundant Scenario 2

Scenario 2

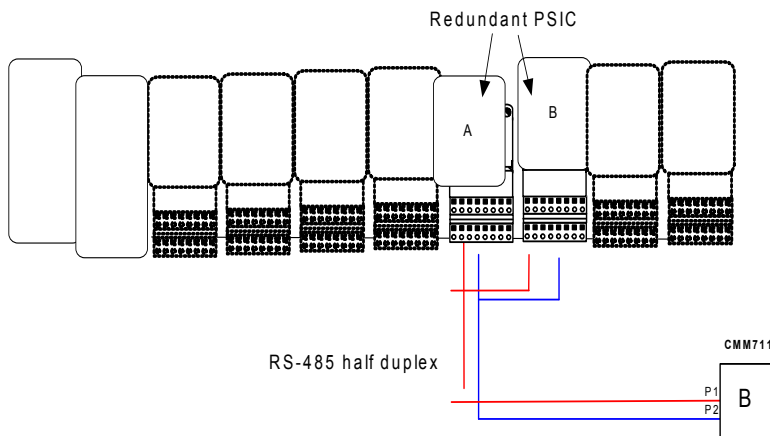
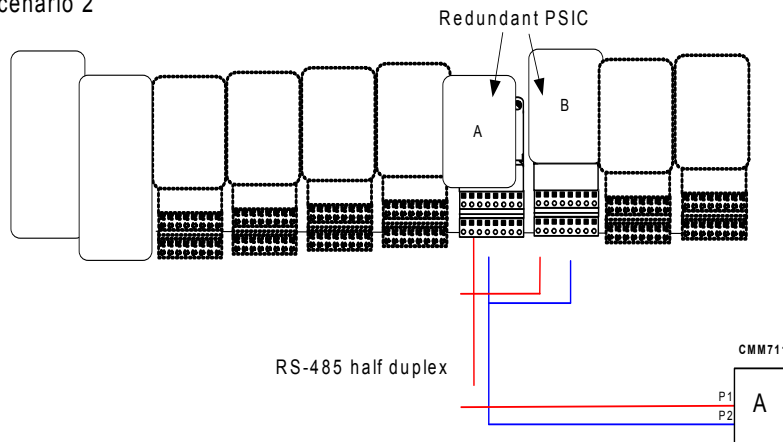

Notes:

1. Controller 1 PSIC A Port 1 and PSIC B Port 1 (Red) communicate with Port 1 of CMM A.
2. Controller 1 PSIC A Port 2 and PSIC B Port 2 (Blue) communicate with Port 2 of CMM A.
3. Controller 2 PSIC A Port 1 and PSIC B Port 1 (Red) communicate with Port 1 of CMM B.
4. Controller 2 PSIC A Port 2 and PSIC B Port 2 (Blue) communicate with Port 2 of CMM B.
5. As secondary, PSIC Port 1 (Red) Pings the port internal to the PSIC only.
6. As secondary, PSIC Port 2 (Blue) Pings the port internal to the PSIC only.
7. If there is a communication failure on PSIC A (either port), then communications automatically switch to PSIC B, or vice versa.
8. In this mechanism there is only one twisted pair of wires per port. If this wire is cut, all communications from the PSIC to the PLC are lost.



Option 4: Redundant Scenario 3

Scenario 3

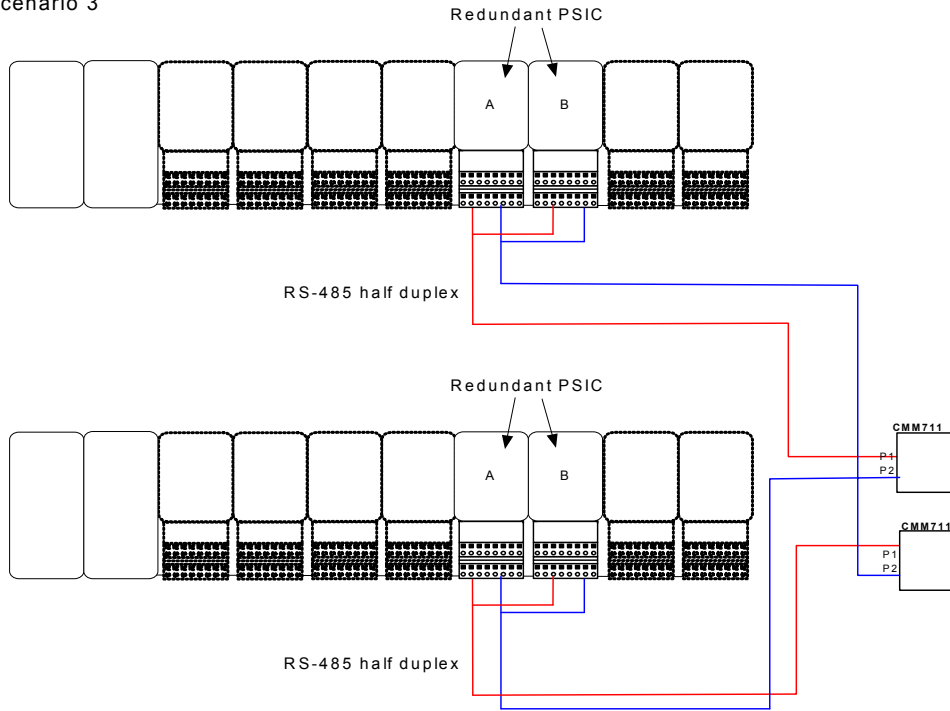

Notes:

1. PSIC A Port 1 and PSIC B Port 1 (Red) communicate with Port 1 of the CMM.
2. PSIC A Port 2 and PSIC B Port 2 (Blue) communicate with Port 2 of the CMM.
3. As secondary, PSIC Port 1 (Red) Pings the port internal to the PSIC only.
4. As secondary, PSIC Port 2 (Blue) Pings the port internal to the PSIC only.
5. If there is a communication failure on PSIC A (either port), then communications automatically switch to PSIC B, or vice versa.
6. In this mechanism there is only one twisted pair of wires per port. If this wire is cut, all communications from the PSIC to the PLC are lost.



3 Downloading the firmware

The driver software distribution comprises 15 files, distributed on a CD. These files must be copied to the DeltaV directory on your ProPlus Workstation. The path is:

\\DeltaV\ctl\ProgSerial\GE90-70

Note that you will have to create the \GE90-70 subdirectory. The following files will be copied:

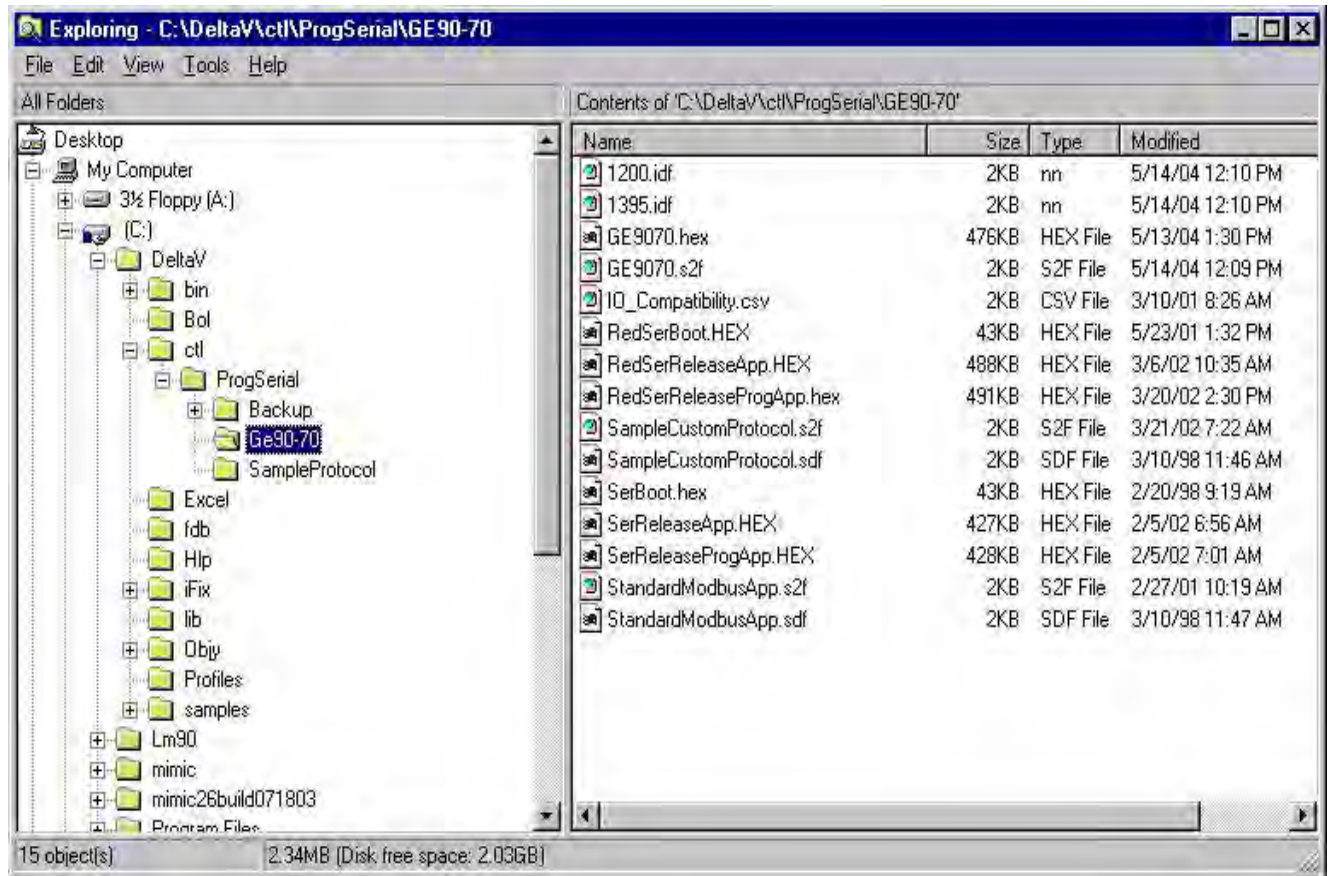



After copy completion, you are ready to program (or upgrade) the Programmable Serial Card with the supplied custom driver software. The steps are as follows:

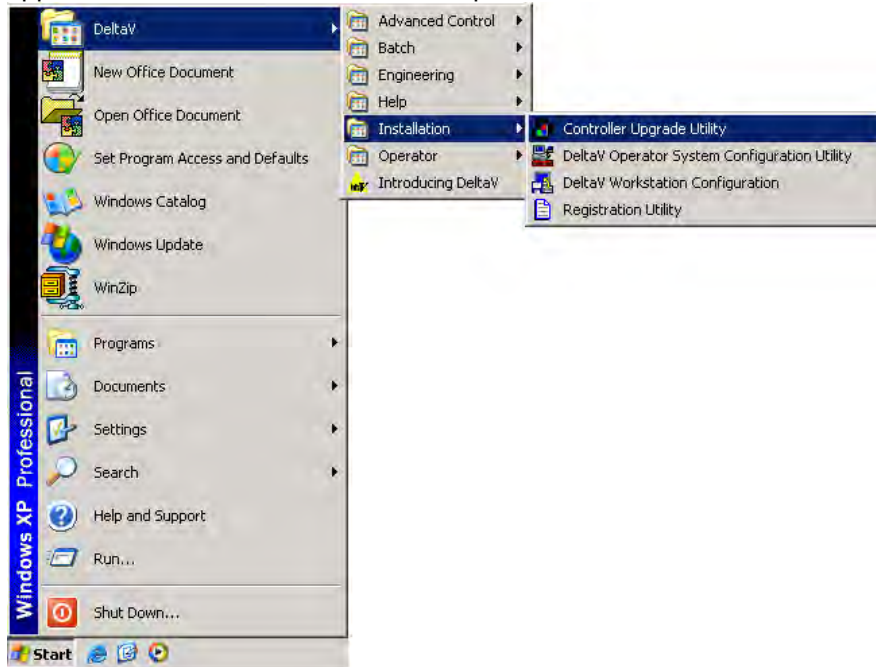

1. Click on the Start button and select DeltaV-> Installation-> Controller Upgrade Utility as shown below, and the following dialog will appear:

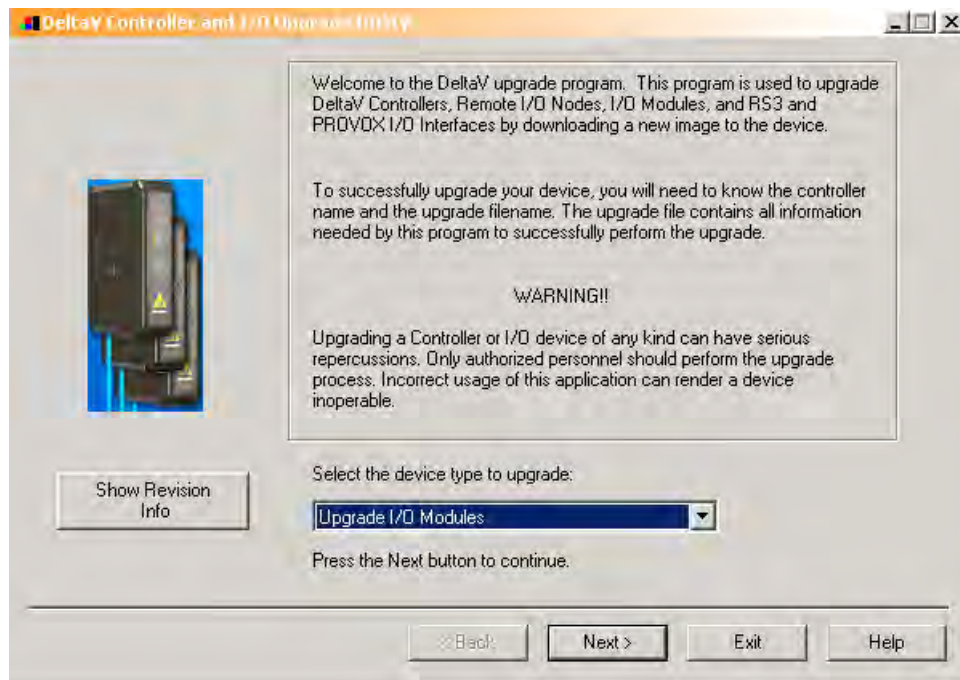

2. Choose Upgrade I/O Modules from the drop down menu and click Next.

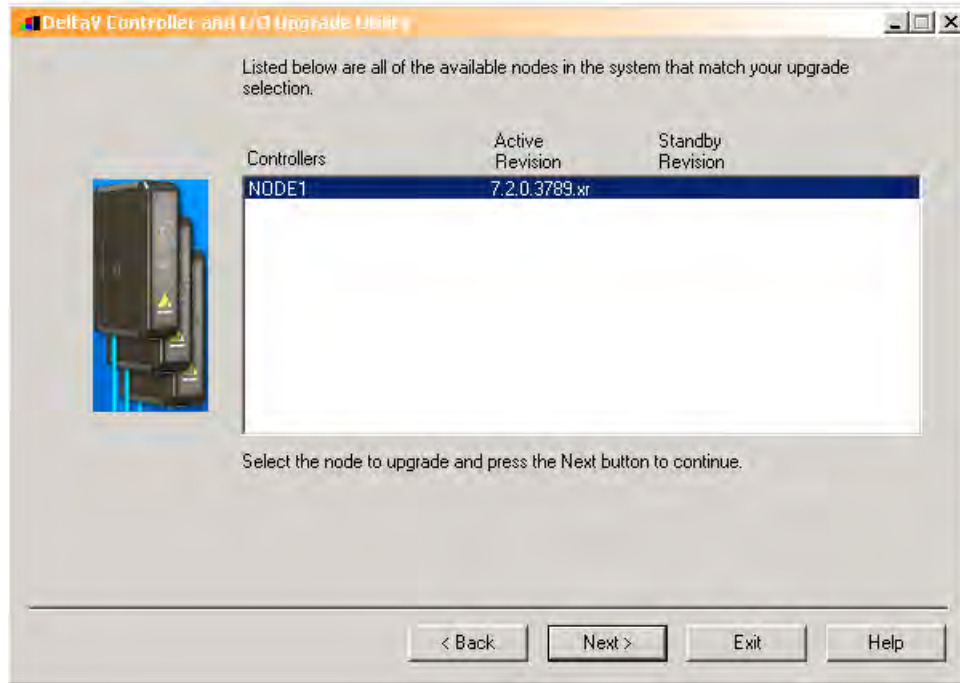

3. The above dialog will appear, listing all the available Controllers in your network. From this dialog, select the appropriate Controller and then Click Next.

4. The following dialog will appear, listing all the I/O modules in your selected Controller. The shown list of I/O modules is an example only. Your list will be different.

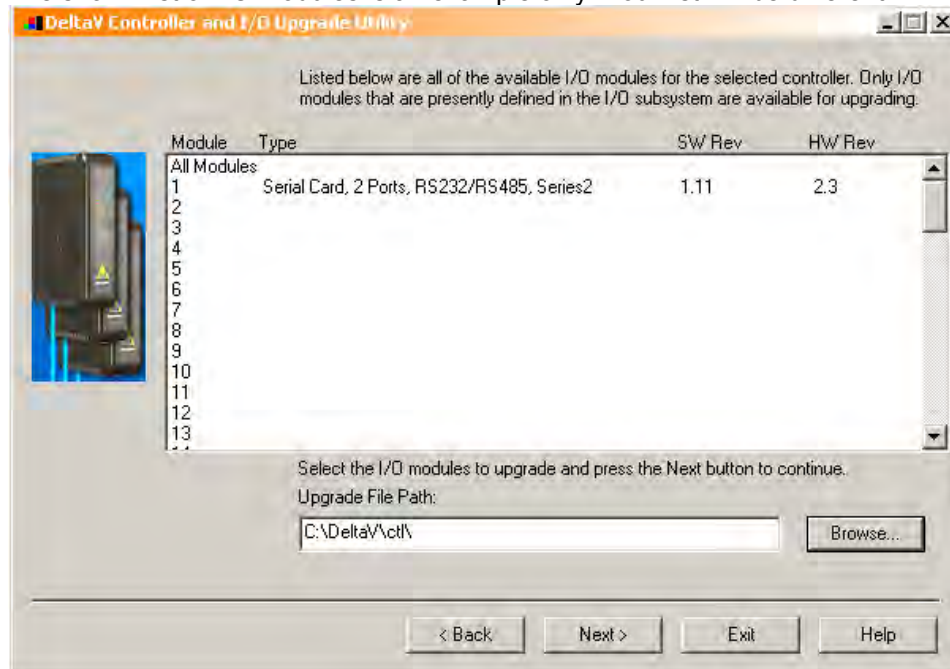

Note: The first time a standard Serial card is upgraded to the GE 90-70 PLC Driver, the dialog will be as shown below. When upgrading an existing Programmable Serial Card, skip Steps 4, 5 and 6, and go to Step 7.

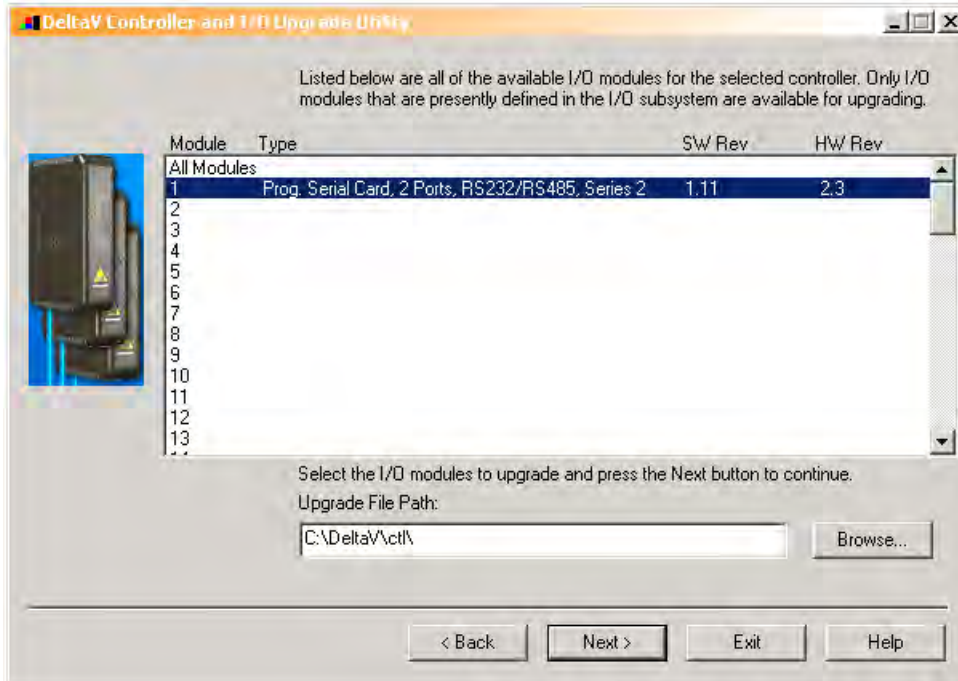

5. Click the Browse button and select the DeltaV path as shown below, and then click Ok. Note that the disk drive could be C or D.

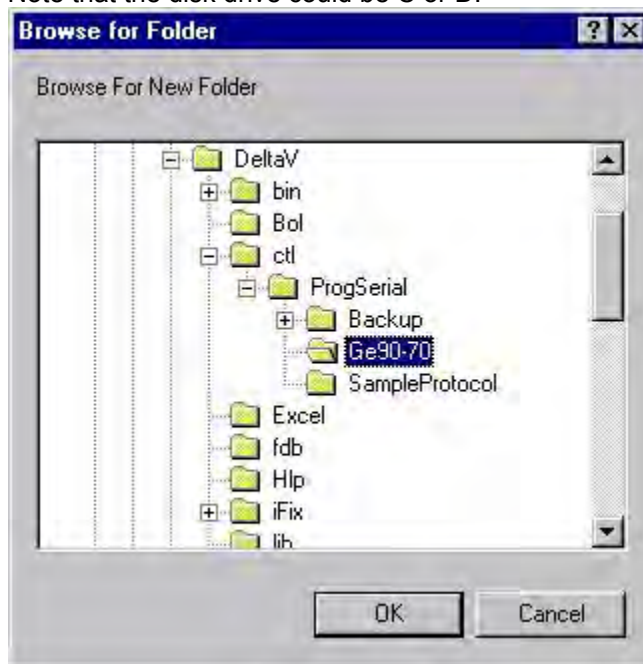



6. Select the I/O module again as shown below and then click Next. Go to Step 9.

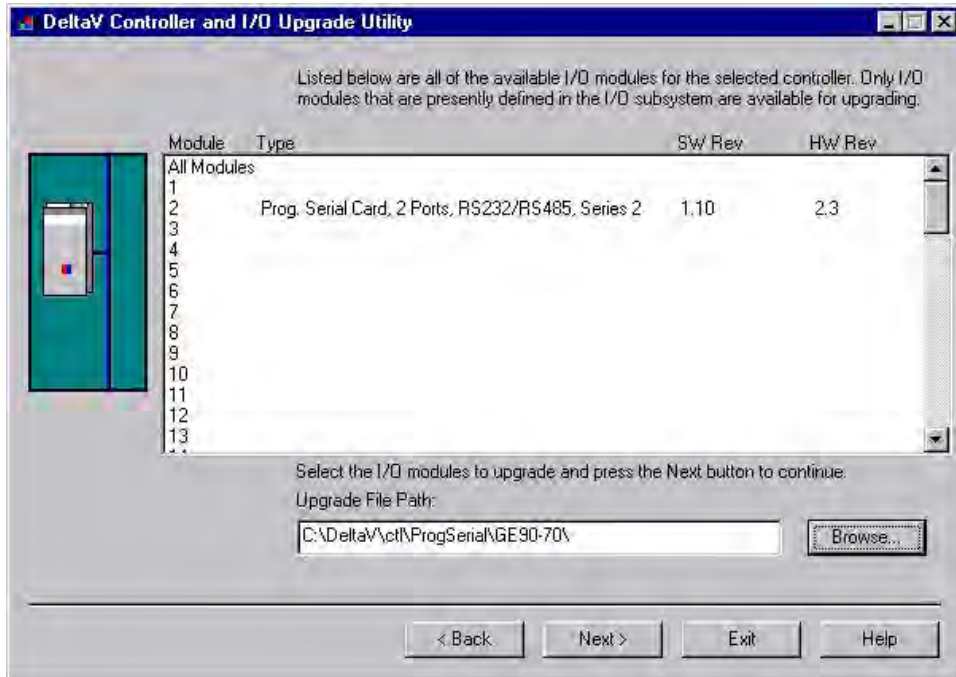

7. If you are upgrading an existing Programmable Serial Card, the dialog will be as shown below. From this dialog, select the Programmable Serial Card I/O Module in the list.

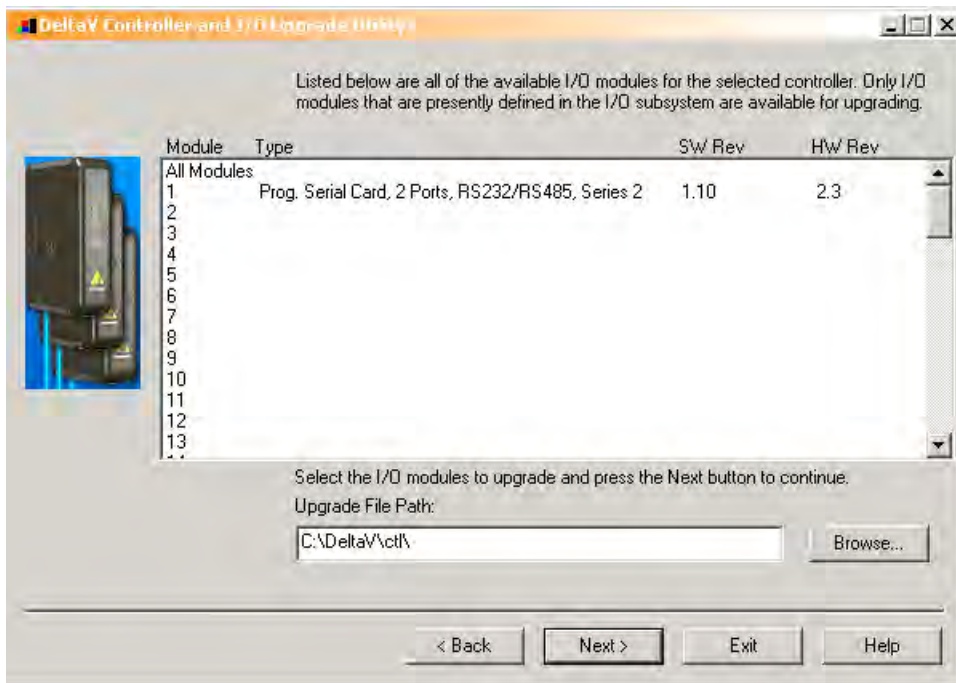

For example, we will select I/O Module 1. This will give you a dialog, from which you will select the file path to where the driver software is located. This path will be:



\\Delta\Vct\ProgSerial \GE90-70\Series 2

Once you are in the specified directory, you will need to select the following file:

GE9070.S2F

This is shown in the following dialog.

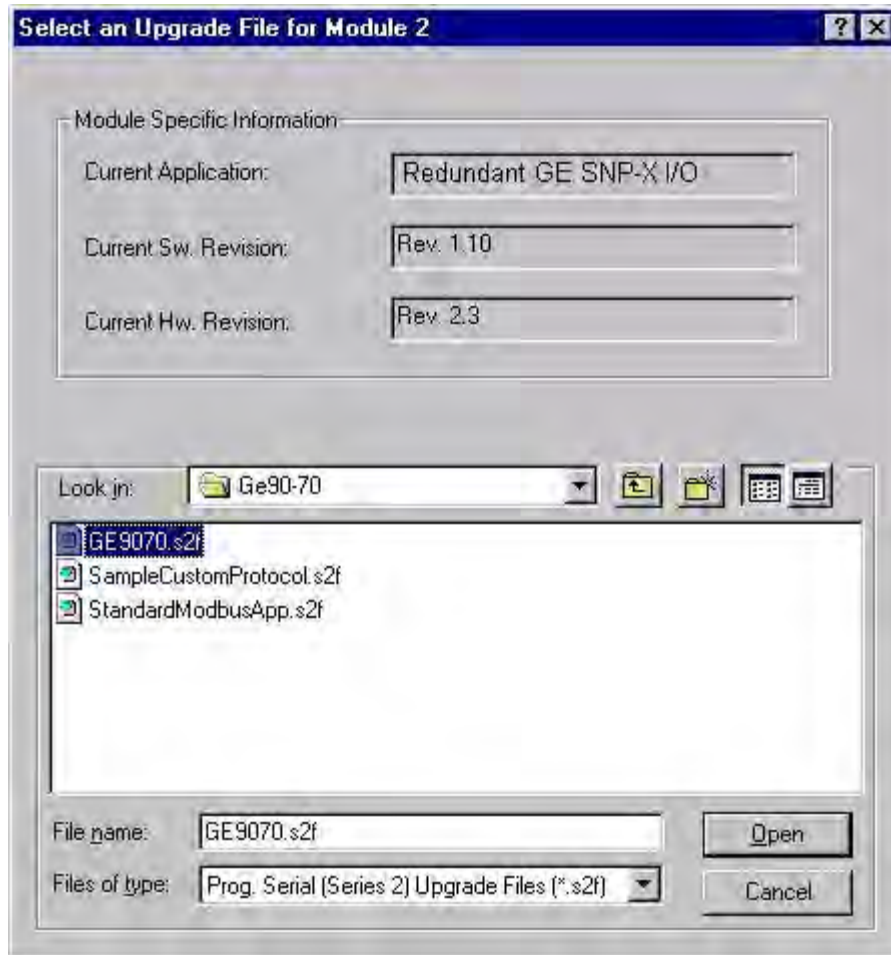

8. After selecting the .S2F file, Click on Open. This dialog will close and you will be back to the following:

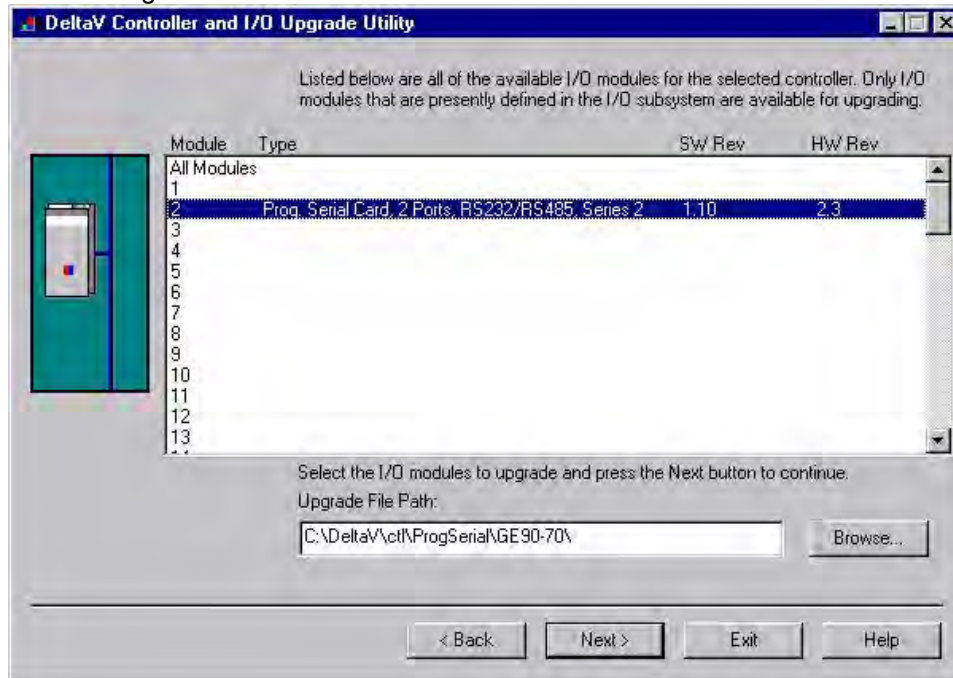

9. In this dialog, Click Next again. You will get the following dialog, confirming the Controller and I/O Module to program.

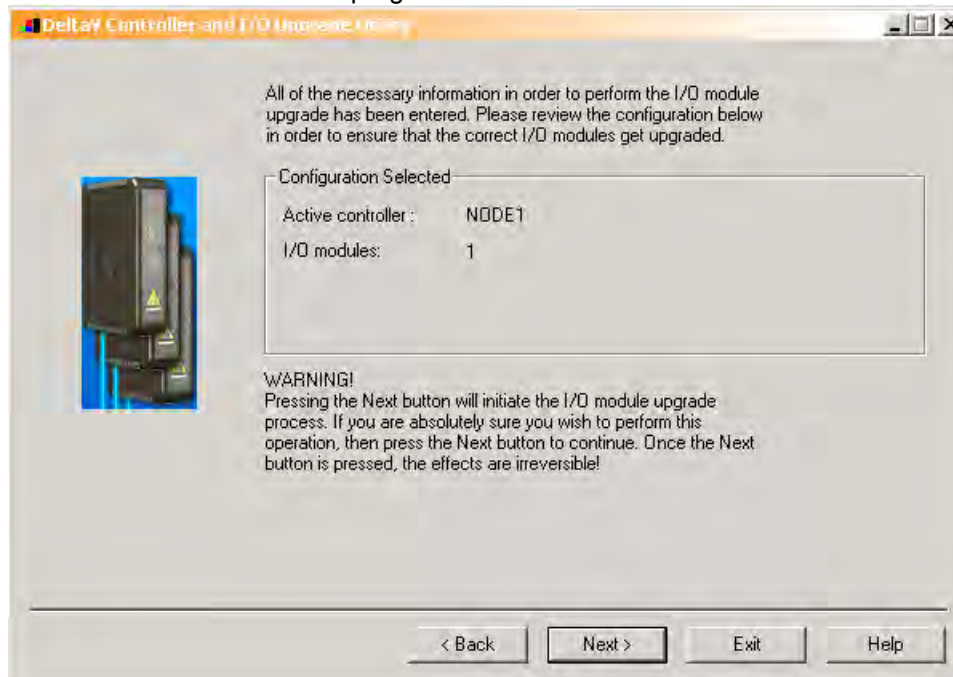

10. Click Next and the I/O Module upgrade process will begin. After completion, you will receive the following dialog, indicating success.

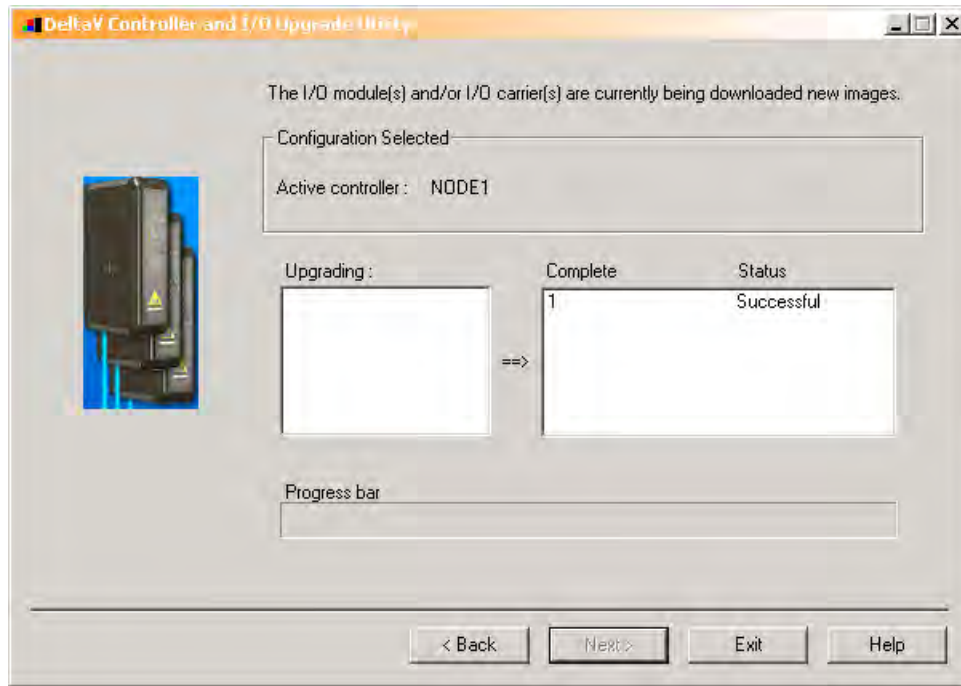

11. This completes the I/O Module upgrade process.



4 CONFIGURATION INFORMATION

The DeltaV Explorer view of a configuration containing a Programmable Serial Card will be as follows, where C1 has a card type of Programmable Serial Card, P01 and P02 are the ports on the card, DEVXX are pseudo devices attached to the ports, and DSXX are configured Datasets for each device.

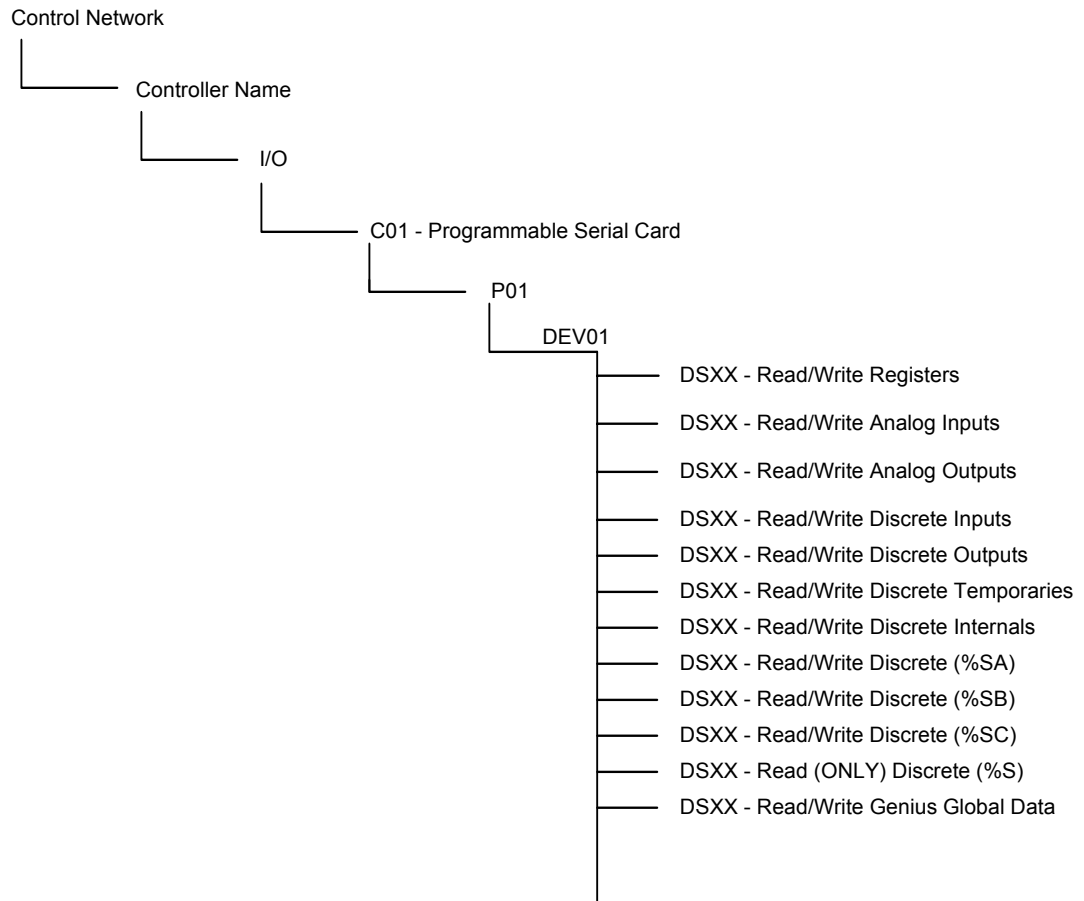



Specifically, each port PXX will be configured with up to 1 device, e.g., DEV01. Each device will be configured with up to 16 datasets, DS01 – DS16 as shown below (in no particular order):

**Dataset Configuration
Table 3**

Port	Devices	Dataset	Mode	Type and Number of Values	Description
P01					
	DEV01				
		DS01	Input/Output	16 Bit, Up To 100 Values	Registers(%R)
		DS02	Input/Output	16 Bit, Up To 100 Values	Analog Inputs(%AI)
		DS03	Input/Output	16 Bit, Up To 100 Values	Analog Outputs(%AQ)
		DS04	Input/Output	Boolean or 8 Bit, Up to 100 Values	Discrete Inputs(%I)
		DS05	Input/Output	Boolean or 8 Bit, Up to 100 Values	Discrete Outputs(%Q)
		DS06	Input/Output	Boolean or 8 Bit, Up to 100 Values	Discrete Temporaries (%T)
		DS07	Input/Output	Boolean or 8 Bit, Up to 100 Values	Discrete Internals(%M)
		DS08	Input/Output	Boolean or 8 Bit, Up to 100 Values	Discrete (%SA)
		DS09	Input/Output	Boolean or 8 Bit, Up to 100 Values	Discrete (%SB)
		DS10	Input/Output	Boolean or 8 Bit, Up to 100 Values	Discrete (%SC)
		DS11	Input	Boolean or 8 Bit, Up to 100 Values	Discrete (%S)
		DS12	Input/Output	Boolean or 8 Bit, Up to 100 Values	Genius Global Data(%G)



4.1 Port Configuration

First, enable the port. Then click on the Advanced Tab and Master mode. Slave is not supported. Specify the retry count, message timeout value in milliseconds, and message delay time. In most cases, you can leave these at their default values. Next, click on the Communications Tab and specify the Port type. The Port type will be RS-232. In general, RS-232 will be used for GE90-70 communications, unless there are distance limitations. If the GE90-70 is more than 50 feet from the PSIC, RS-485 should be used. Lastly, select the Baud rate, Parity, Data bits and Stop bits parameters; these must match the GE90-70 settings.

4.2 Device Configuration

Specify devices, as shown above. There will be one device under each port.

4.3 Dataset Configuration

Datasets contain the GE90-70 information, and must be configured as described in Table 3.

4.3.1 Data Direction:

The Data Direction for should be defined as Input or Output. Output mode can be used for all types except Discrete (%S).

4.3.2 Output Mode:

Output mode should be 0 for Write Block Mode and 1 for Write Single Values Mode.

- Write Block Mode
 - Writes the entire dataset to the GE90-70 when any value in the dataset has changed.
- Write Single Values Mode
 - Write only the value changed in a dataset to the GE90-70.

4.3.3 DeltaV Data Type:

For Registers, Analog Outputs, and Analog Inputs the DeltaV Data Type should be 16-Bit Signed or Unsigned. All other types can either be Boolean or 8-Bit Signed or Unsigned.



4.3.4 DeviceDataType

The following device data types are available.

Table 13

DeviceDataType	Description
1	Registers (%R)
2	Analog Inputs (%AI)
3	Analog Outputs (%AQ)
4	Discrete Inputs (%I)
5	Discrete Outputs (%Q)
6	Discrete Temporaries (%T)
7	Discrete Internals (%M)
8	Discrete (%SA)
9	Discrete (%SB)
10	Discrete (%SC)
11	Discrete (%S)
12	Genius Global Data (%G)

4.3.5 Data Start Address and Number of Values

Data Start Address should be the offset for where reading or writing should begin for a particular type. The number of values should be set to the number of values you would like to read or write on the GE90-70.

4.3.6 Special Data

Special Data will not be used.



5 Operational Check

5.1 Scope

The following sections provide some assistance to ensure the interface is working properly.

5.2 Verify Hardware and Software Version Number

The user can verify that the GE90-70 driver has been installed using the DeltaV Diagnostics tool. The Diagnostics tool will show the Hardware Revision No. (HwRev) and the Software Revision No. (SwRev).

To begin the DeltaV Diagnostic tool select Start-> DeltaV-> Operator-> Diagnostics. In the Diagnostics tool expand the Controller, I/O and then double click on the Programmable Serial Interface Card that has the driver installed.

The following information will be displayed:

:	:	:
HwRev	Hardware Revision	1.10 (or later)
SwRev	Software Revision	2.3 (or later)

5.3 Verify Configuration

- Verify port configuration: The serial port must be enabled. User needs to make sure communication settings such as baud rate, parity, and number of data bits match the field device settings.
- Verify dataset configuration: The datasets configured must be as shown above.

5.4 Verify I/O Communication With Control Studio

User can create I/O modules in the control studio to verify correct values are being written out. An example module is shipped with the distribution. This module shows methods for writing text to the datasets and also how to handle time.

5.5 Using Diagnostics

- Verify PSIC communication: Select the PSIC on Diagnostics and press the right mouse button. Select Display Real -Time Statistics from the drop down menu. If the Programmable Serial Interface Card is functioning then the user will see the Valid Responses counter and the Async and/or Sync Transactions counters incrementing. There will not be any error counting up.



- Verify port statistics: Select the Port on the Programmable Serial Interface Card and press the right mouse button. Then select Display Port Statistics from the drop down menu. Verify that the port communications statistics are being displayed properly and are counting as expected for the protocol's functionality.
- Verify dataset values: Select a dataset and press the right mouse button. Select View Dataset Registers from the Drop down window. Verify that the dataset values are displayed as expected.

5.6 LED Indication

The Yellow LED for the port should be on solid when all communications on that port are valid. The Yellow LED should be blinking if there is some valid communications and some communications with errors on that port. The Yellow LED should be OFF if there are no valid communications on that port.



6 DeltaV–Field Device Electrical Interface

The electrical interface between DeltaV and field devices conforms to the RS-232 and RS-422/485 standards.

Each PSIC has 2 ports, which function independently. The distance between the serial card and the field device can be as much as 5000 feet, per the RS-422/485 standard. When using RS-232, the distance is limited to 50 feet. Section 6.1 shows the pin assignments for the PSIC serial terminal block.

6.1 Pin Assignments for DeltaV PSIC

RS-232 Standard

Terminal Number	Signal Description
1	Port 1 - Isolated Ground (GND)
2	Unused
3	Port 1 – Transmit Data (TxD)
4	Unused
5	Port 1 – Receive Data (RxD)
6	Unused
7	Port 1 – Data Terminal Ready (DTR)
8	Port 1 – Data Set Ready (DSR)
9	Port 2 - Isolated Ground (GND)
10	Unused
11	Port 2 – Transmit Data (TxD)
12	Unused
13	Port 2 – Receive Data (RxD)
14	Unused
15	Port 2 – Data Terminal Ready (DTR)
16	Port 1 – Data Set Ready (DSR)



RS-422/485 Half Duplex Standard

Terminal Number	Signal Description
1	Port 1 – Isolated Ground (GND)
2	Port 1 - Data +
3	Unused
4	Port 1 - Data -
5	Unused
6	Unused
7	Unused
8	Unused
9	Port 2 – Isolated Ground (GND)
10	Port 2 – Data +
11	Unused
12	Port 2 - Data -
13	Unused
14	Unused
15	Unused
16	Unused

RS-422/485 Full Duplex Standard

Terminal Number	Signal Description
1	Port 1 – Isolated Ground (GND)
2	Port 1 – TxD +
3	Unused
4	Port 1 – TxD -
5	Unused
6	Port 1 – RxD +
7	Unused
8	Port 1 – RxD -
9	Port 2 – Isolated Ground (GND)
10	Port 2 – TxD +
11	Unused
12	Port 2 – TxD -
13	Unused
14	Port 2 – RxD +
15	Unused
16	Port 2 – RxD -



M Y N A H™

POWERFUL SOLUTIONS FOR DIGITAL PLANTS

6.2 Wiring Connections

IFor additional DeltaV cabling information, please refer to the DeltaV Books Online documentation. For GE90-70 cabling/jumper information, refer to Series 90 - PLC Serial Communications Users Manual (gfk0582d), Chapter 8.



M Y N A H™

POWERFUL SOLUTIONS FOR DIGITAL PLANTS

7 Technical Support

For technical support or to report a defect, please give Mynah Technologies a call at (636) 681-1555. If a defect is discovered, please document it in as much detail as possible and then fax your report to us at (636) 681-1660.

For Product functionality questions, ask for the people in the following order:

1. David Story
2. Tony Kerr

For Commercial issues, ask for people in the following order:

1. Martin Berutti
2. Jane Wagner

You can also send us your questions via e-mail. Our address is:

support@mynah.com

Thank you for using DeltaV.