



M Y N A HSM

**Lauda Proline Thermostat Driver
Programmable Serial Interface Card
Series 2**

USER MANUAL

Rev. P1.12

March 10, 2005

DeltaV is a trademark of Emerson Process Management, Inc © Emerson Process Management, Inc. 1998, 1999.
All rights reserved.

Printed in the U.S.A.

While this information is presented in good faith and believed to be accurate, MYNAH Technologies does not guarantee satisfactory results from reliance upon such information. *Nothing contained herein is to be construed as a warranty or guarantee, express or implied, regarding the performance, merchantability, fitness or any other matter with respect to the products*, nor as a recommendation to use any product or process in conflict with any patent. MYNAH Technologies reserves the right, without notice, to alter or improve the designs or specifications of the products described herein.



1 INTRODUCTION

1.1 Scope

This document is the User Manual for the Lauda Thermostat driver firmware for the Emerson Process Management (EPM) DeltaV Control System; it provides information required to install, configure, and maintain the driver firmware on the DeltaV Series 2 Programmable Serial Interface Card (PSIC). The reader should be familiar with EPM's DeltaV PSIC and connected Lauda Thermostat devices.

The section *Document Format* briefly describes the contents of each section of this manual. *System Specifications* outlines hardware and software requirements for the Lauda Thermostat Driver (P1.12) firmware. This driver is not available for Series 1 serial cards.

1.2 Document Format

This document is organized as follows:

Table 1

Introduction	Describes the scope and purpose of this document.
Theory of Operation	Provides a general functional overview of the Lauda Thermostat Driver.
Downloading Firmware	Describes downloading procedures for the Lauda Thermostat Driver firmware on to the DeltaV PSIC.
Configuration Information	Describes procedures and guidelines for configuring the DeltaV PSIC.
Operational Check	Provides tips and assistance to ensure PSIC is properly setup and configured.
DeltaV–Field Device Electrical Interface	Describes the electrical interface between DeltaV and the Lauda Thermostat device. Also describes the cable pin assignments for RS-232 and RS-422/485 communications.
Technical Support	Describes who to call if you need assistance.
Example	Describes how to configure a device with input and output datasets.



1.3 System Specifications

The following table lists the minimum system requirements for the Lauda Thermostat Driver:

Table 2

Firmware	Lauda Thermostat Driver Firmware (P1.12)
Protocol Compatibility	Lauda Proline Thermostat Operators Handbook. YACE0072/21.04.04 (RS232/RS485 Interface)
Software Requirements	DeltaV System Software (Release 6.3.2 or later) installed on a hardware-appropriate Windows NT or later workstation configured as a ProfessionalPlus for DeltaV Serial Interface Port License (VE4102)
Minimum DeltaV Hardware Requirements	FRSI DeltaV Serial Interface Series 2, Hardware PN: 12P2506X022 FRSI DeltaV M3, M5, MD or Series 2 MD Controller, Power Supply and 2 wide controller carrier FRSI 8 wide I/O card carrier



2 THEORY OF OPERATION

The Programmable Serial Interface Card (PSIC) has 2 ports which can be configured for RS-232, RS-422/RS-485 Half Duplex or RS-422/RS-485 Full Duplex communications with external devices. For communications with the Lauda Thermostat devices, any mode may be used.

The DeltaV Serial Card Driver functionality will be as follows.

1. The driver will be flashed into the PSIC.
2. The driver will run in Master mode only and be responsible for sending commands to the Thermostat units. The Thermostat will respond with information, which will be reported to DeltaV in dataset registers.
3. The two ports of the PSIC work independently, each connected to a Lauda unit. The Lauda Thermostat devices may be multidropped in RS485 mode.

The following 2 diagrams show PSIC connectivity with Lauda Thermostat devices.

RS232/RS485 Setup

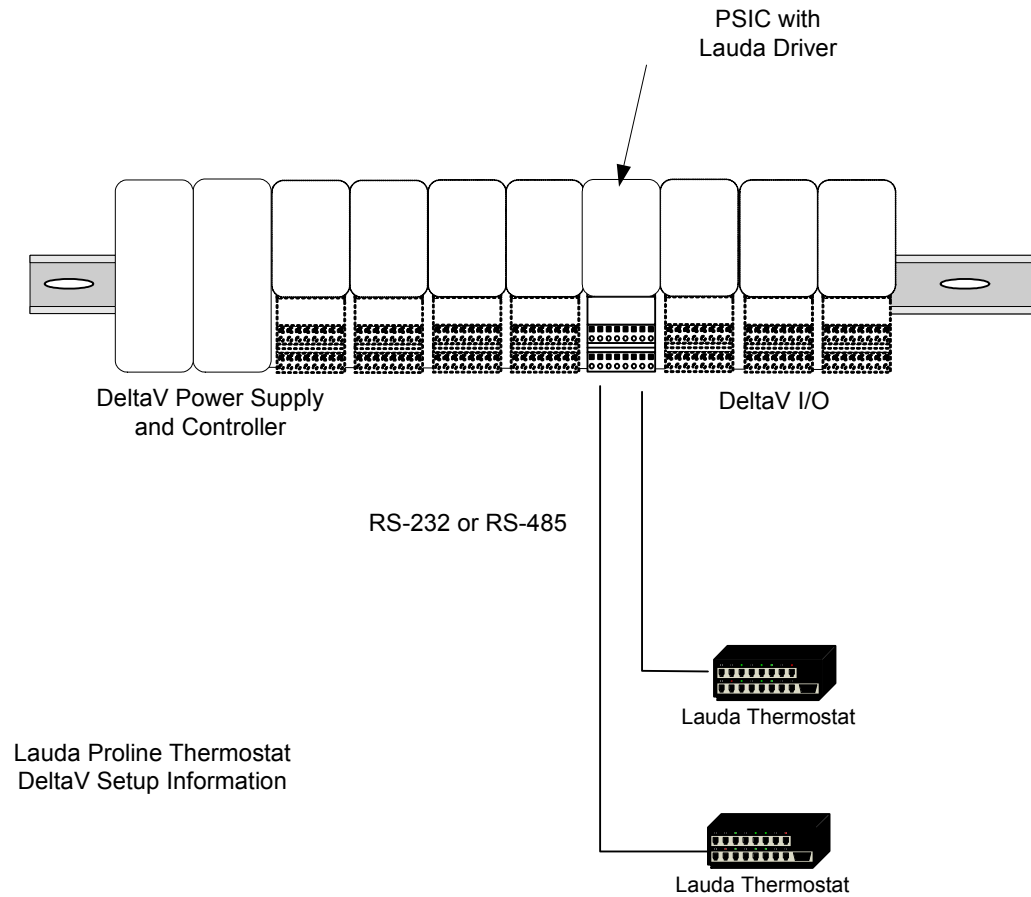

RS485 Multidrop Setup

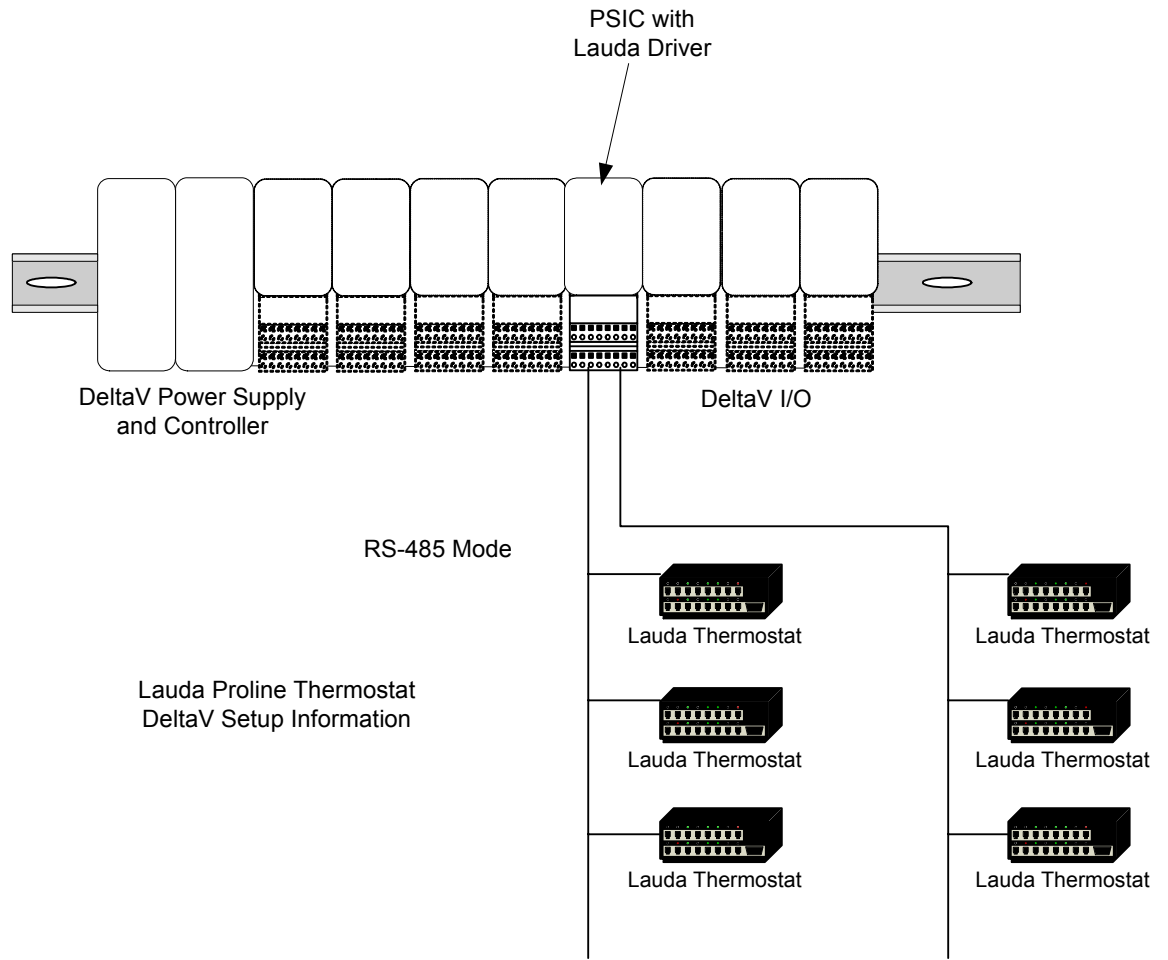



3 Downloading the firmware

The driver software distribution comprises 15 files, distributed on a CD. These files must be copied to the DeltaV directory on your ProPlus Workstation. The path is:

\DeltaV\ctl\ProgSerial\S2LaudaThermostat

Note that you will have to create the \S2LaudaThermostat subdirectory. The following files will be copied:

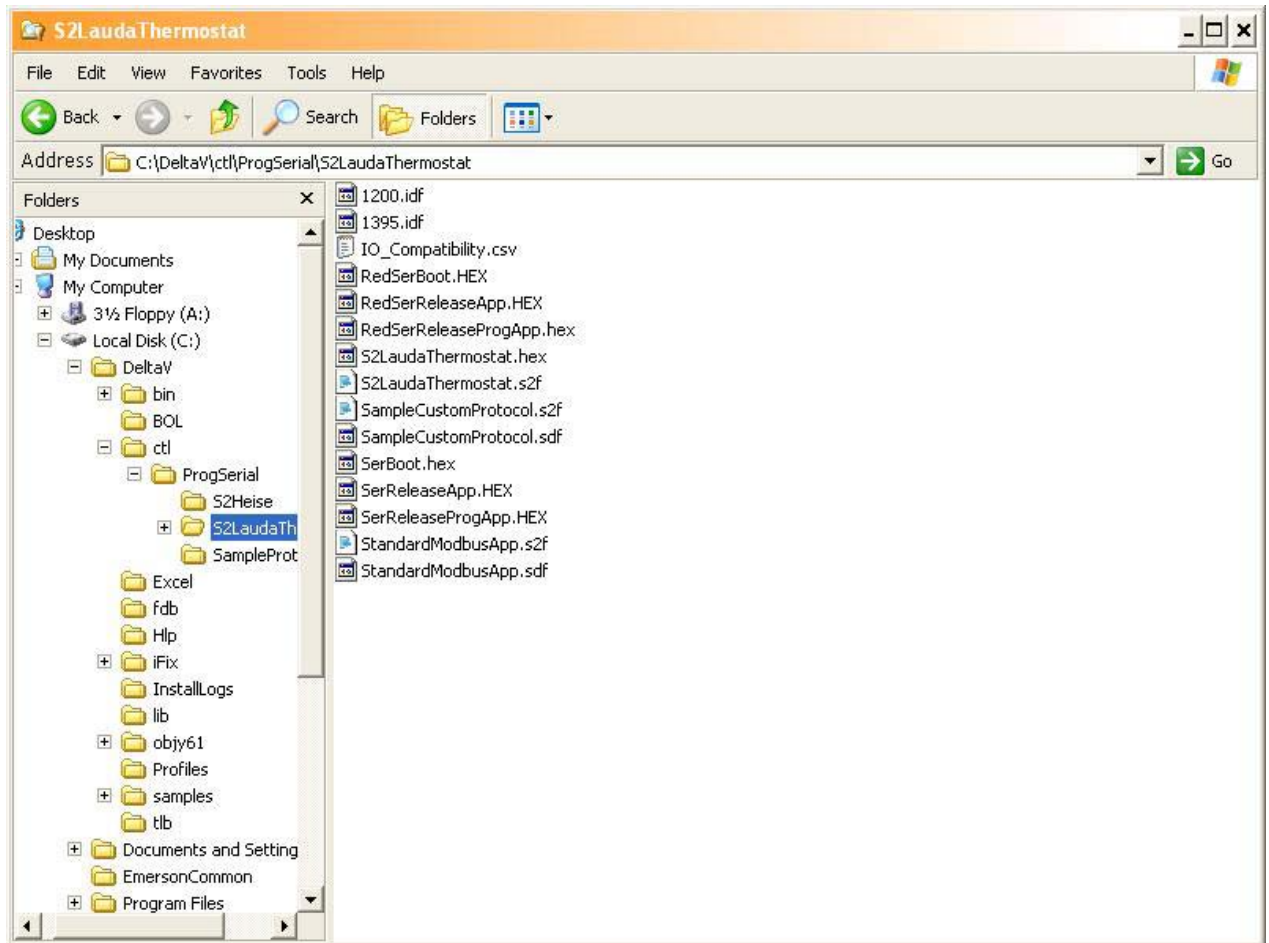



After copy completion, you are ready to program (or upgrade) the Programmable Serial Card with the supplied custom driver software. The steps are as follows:

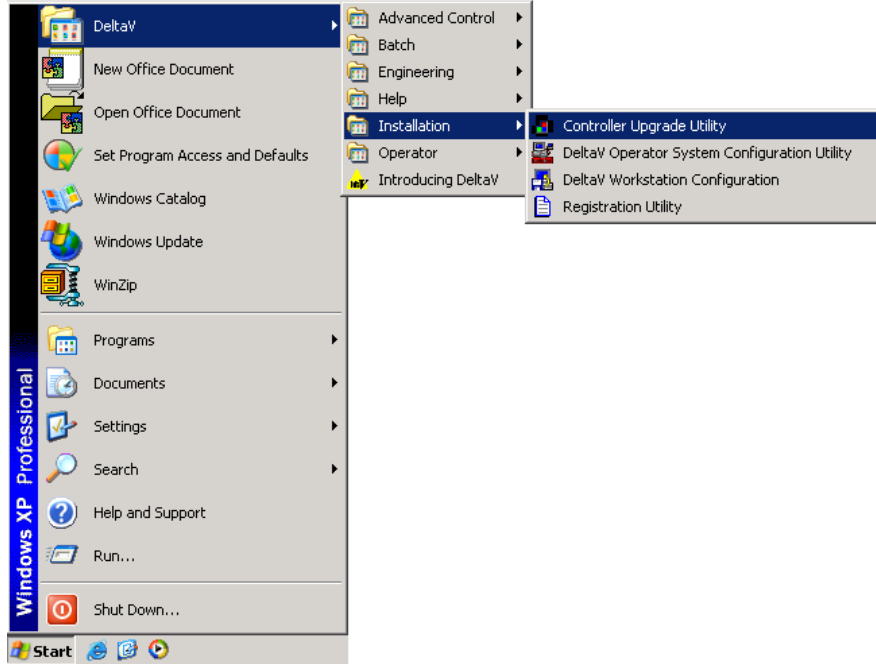

1. Click on the Start button and select DeltaV-> Installation-> Controller Upgrade Utility as shown below, and the following dialog will appear:

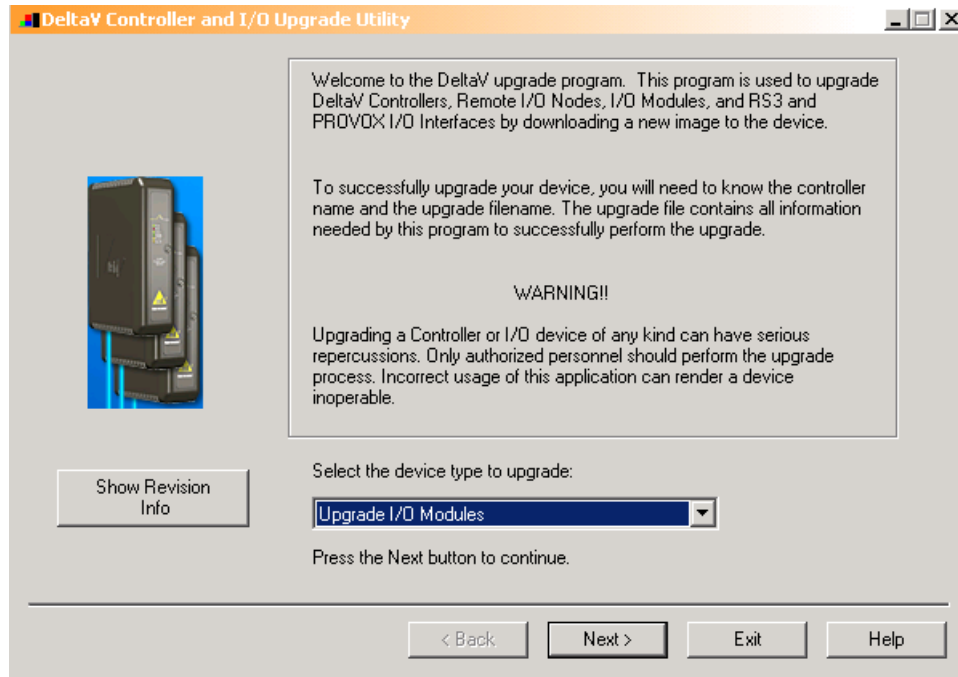

2. Choose Upgrade I/O Modules from the drop down menu and click Next.

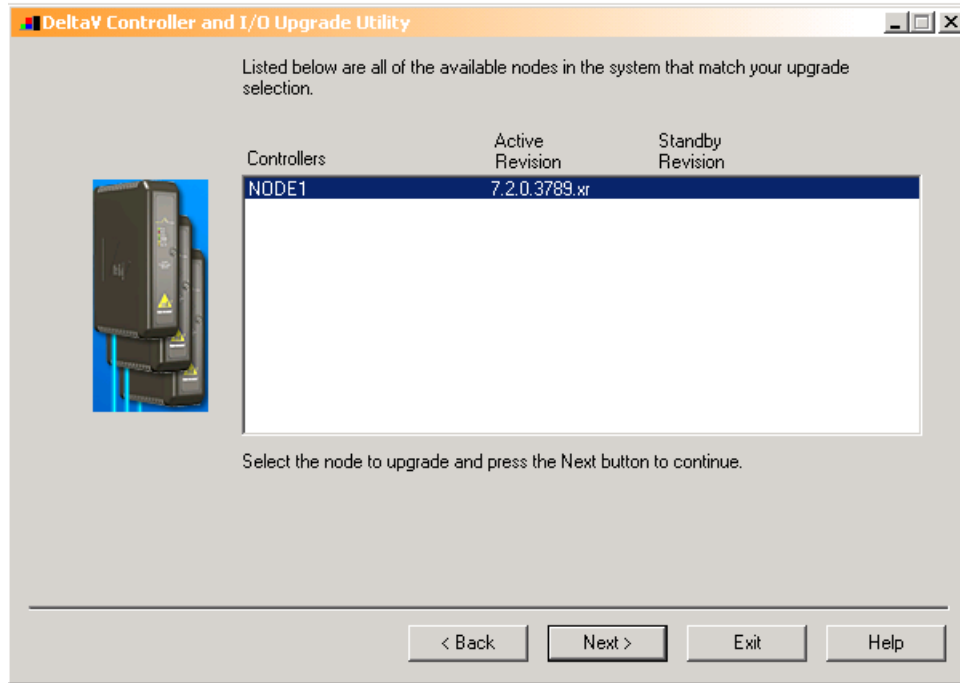

3. The above dialog will appear, listing all the available Controllers in your network. From this dialog, select the appropriate Controller and then Click Next.

4. The following dialog will appear, listing all the I/O modules in your selected Controller. The shown list of I/O modules is an example only. Your list will be different.

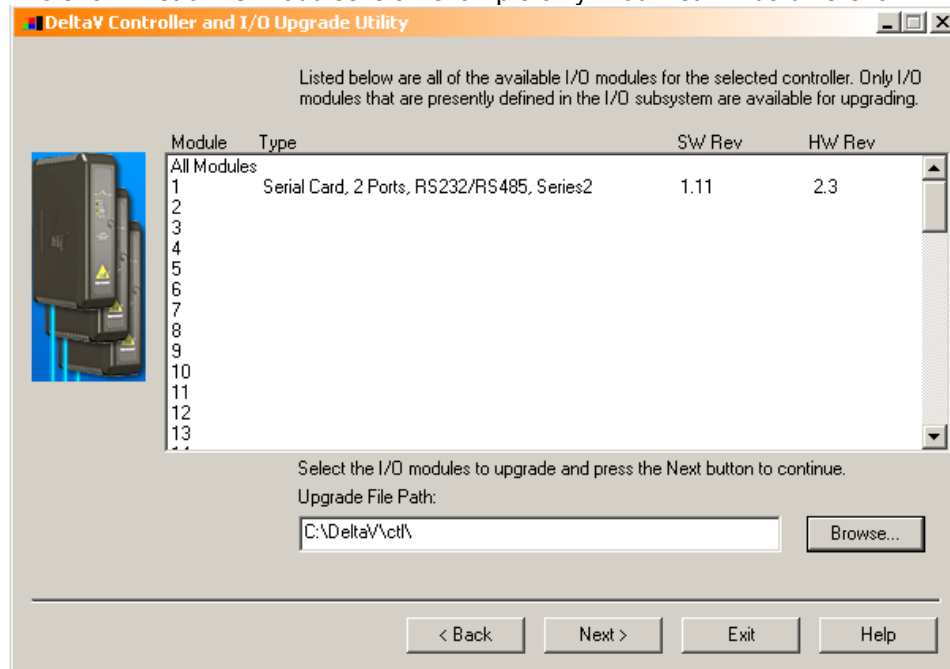

Note: The first time a standard Serial card is upgraded to the Lauda Thermostat Driver, the dialog will be as shown below. When upgrading an existing Programmable Serial Card, skip Steps 4, 5 and 6, and go to Step 7.

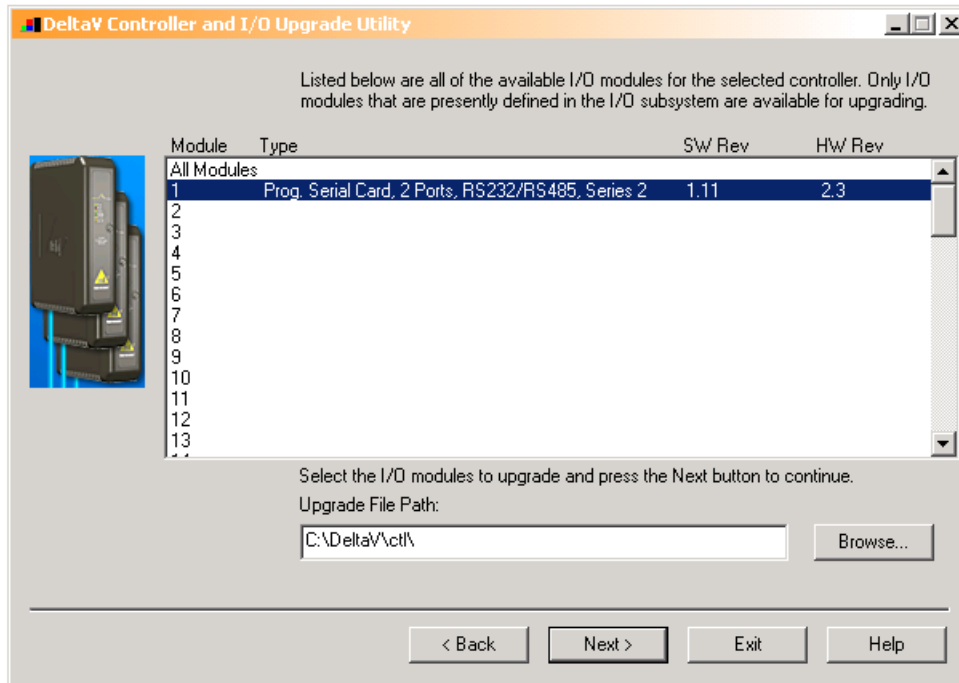

5. Click the Browse button and select the DeltaV path as shown below, and then click Ok. Note that the disk drive could be C or D.

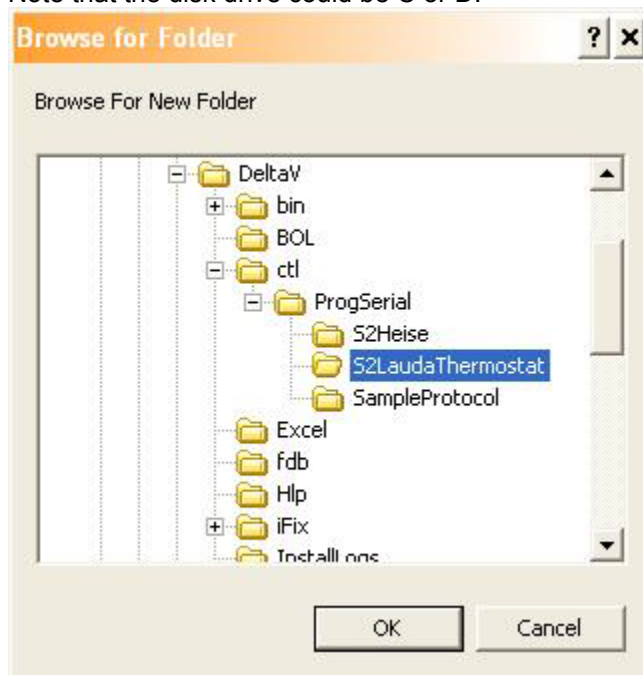



6. Select the I/O module again as shown below and then click Next. Go to Step 9.

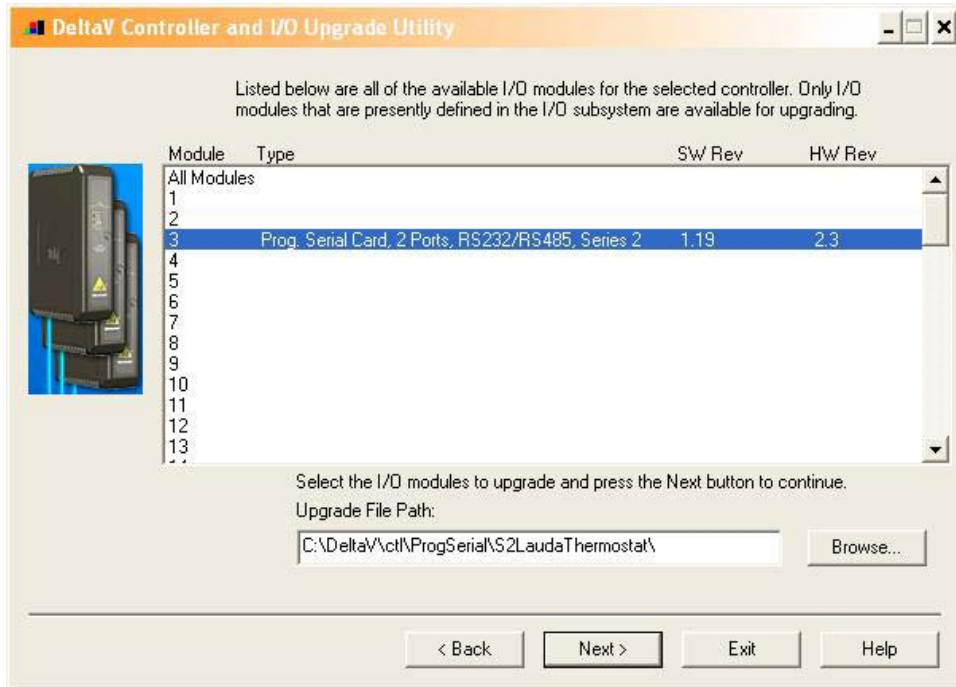

7. If you are upgrading an existing Programmable Serial Card, the dialog will be as shown below. From this dialog, select the Programmable Serial Card I/O Module in the list.

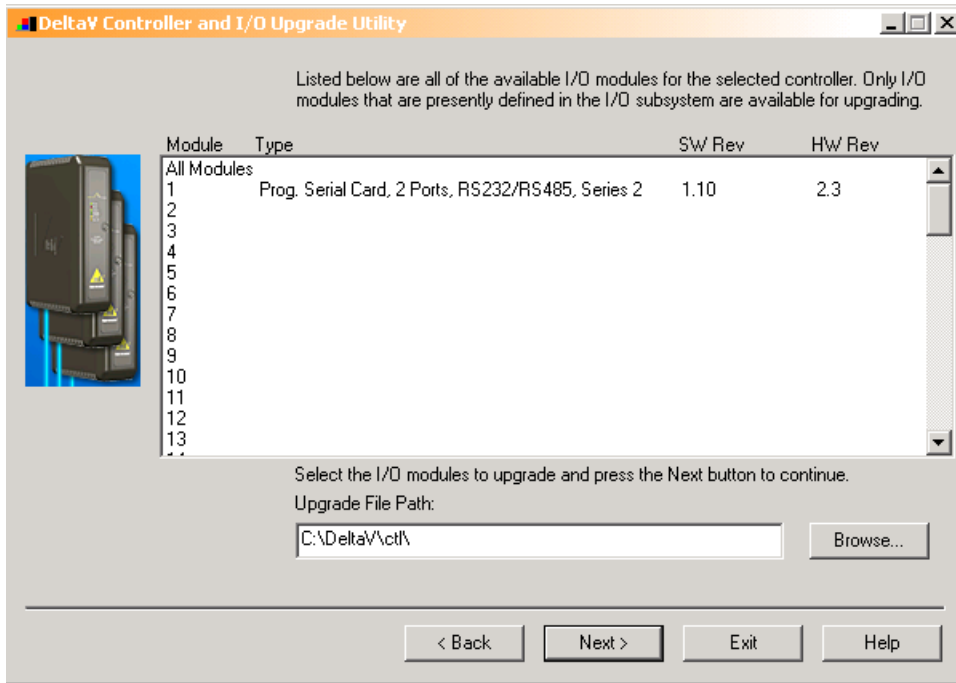

For example, we will select I/O Module 1. This will give you a dialog, from which you will select the file path to where the driver software is located. This path will be:



`\\Delta\ctrl\ProgSerial \S2LaudaThermostat\`

Once you are in the specified directory, you will need to select the following file:

S2LaudaThermostat.S2F

This is shown in the following dialog.

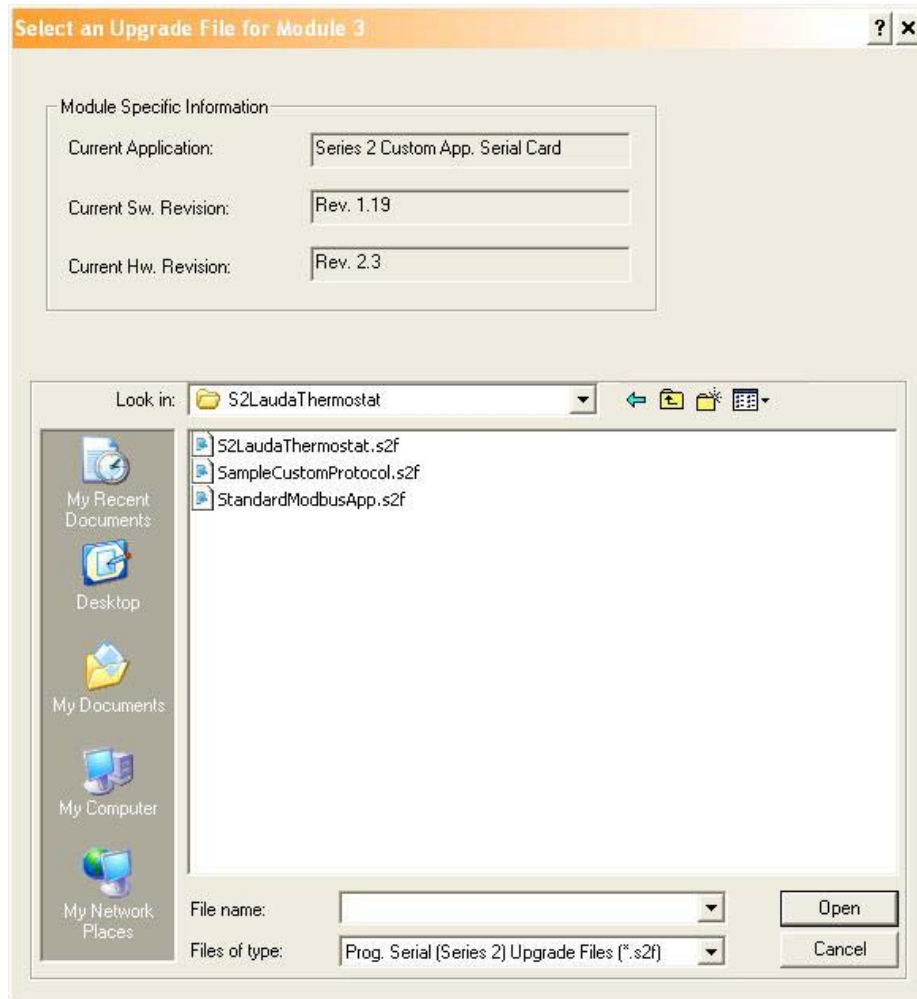



8. After selecting the .S2F file, Click on Open. This dialog will close and you will be back to the following:

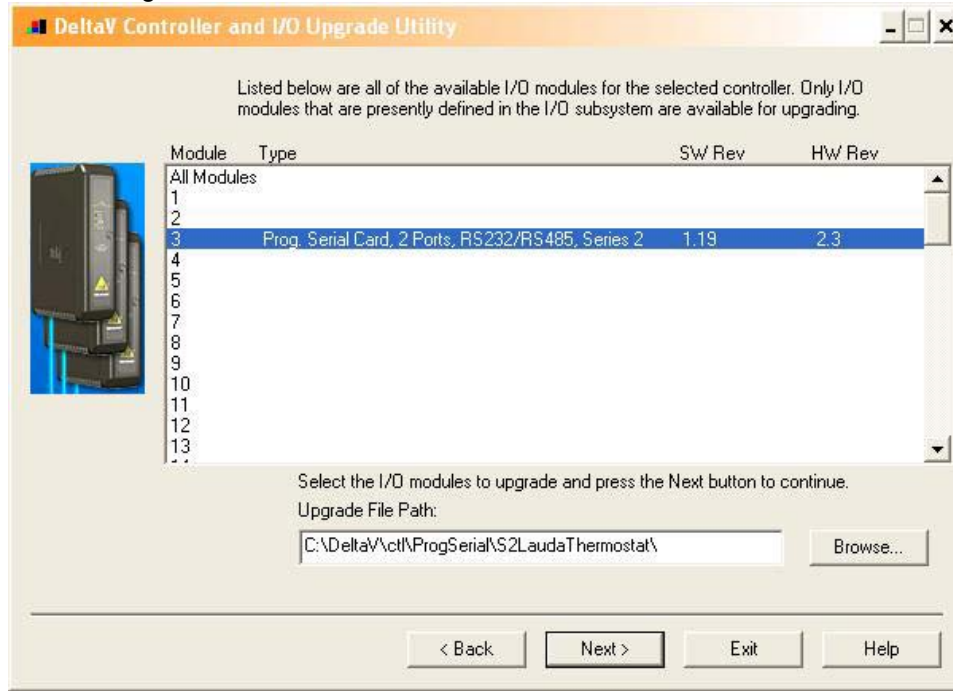

9. In this dialog, Click Next again. You will get the following dialog, confirming the Controller and I/O Module to program.

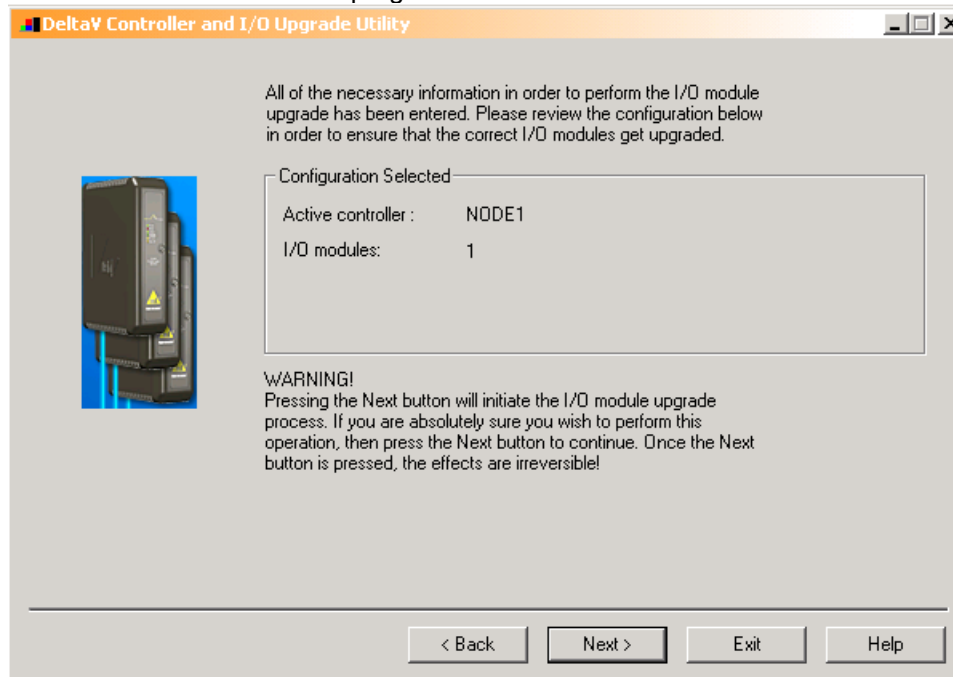

10. Click Next and the I/O Module upgrade process will begin. After completion, you will receive the following dialog, indicating success.

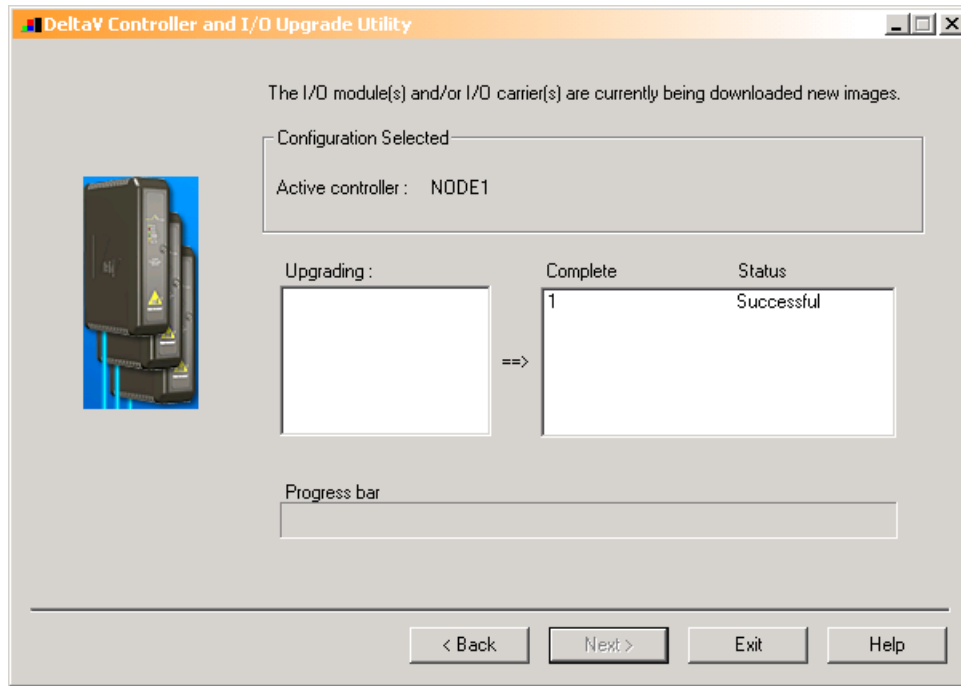

11. This completes the I/O Module upgrade process.



4 CONFIGURATION INFORMATION

The DeltaV Explorer view of a configuration containing a Programmable Serial Card will be as follows, where C01 has a card type of Programmable Serial Card, P01 and P02 are the ports on the card, DEVXX are pseudo devices attached to the ports, and DSXX are configured Datasets for each device.

The following is the default configuration for use with this driver. Up to 7 datasets can be defined per device in order to retrieve all supported data. Not all 7 need to be defined, if all your interested in is PV values then only the Read PV dataset needs to be defined. You will learn more about the device data types later in this document.

**Dataset Configuration
Table 3**

Port	Devices	Dataset	Mode	Type and Number of Values	Description
P01					
	DEV01				
		DS1	Input	Floating Point, 6 Values	Reads the PV Values
		DS2	Input/Output	Floating Point, 5 Values	Reads/Write SP Values
		DS3	Input/Output	Floating Point, 14 Values	Read/Write PAR Values
		DS4	Input	Floating Point, 6 Values	Read DI and DO Values
		DS5	Input/Output	Floating Point, 5 Values	Read/Write Mode Values
		DS6	Input	Floating Point, 10 Values	Read Type, Version, and Status Values
		DS7	Input	Floating Point, 5 Values	Read RMP Values

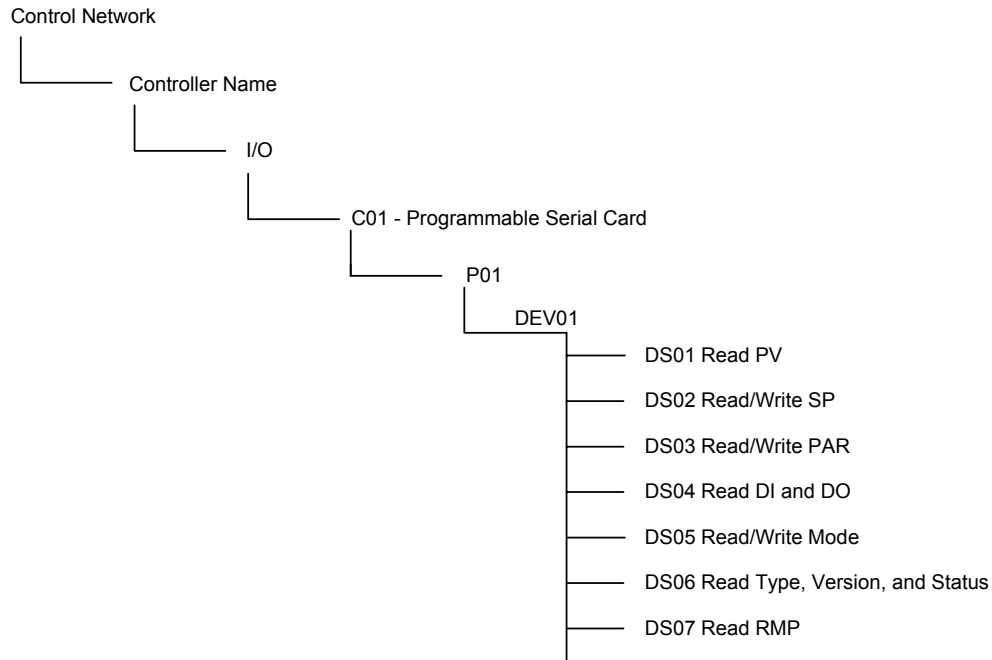

4.1 Port Configuration

First, enable the port. Then click on the Advanced Tab and Master mode. Slave is not supported. Specify the retry count, message timeout value in milliseconds, and message delay time. In most cases, you can leave these at their default values. Next, click on the Communications Tab and specify the Port type. The Port type will be RS-232 or RS485. In general, RS-232 will be used for 1 device per port communications, unless there are distance limitations. If the Lauda is more than 50 feet from the PSIC, RS-485 should be used. Lastly, select the Baud rate, Parity, Data bits and Stop bits parameters; these must match the Lauda Thermostat settings.

4.2 Device Configuration

Specify devices, as shown above. There will be one device under each port.

4.3 Dataset Configuration

Datasets contain the Lauda information, and must be configured as described in Table 3.

4.3.1 Data Direction:

All device data types support Input mode however only SP, PAR, and MODE support output mode. When output mode is used a check should be placed next to readback in order to verify all writes. Be careful when using output mode as some registers may not support Writing, see register mapping in section 4.3.7 for more information.

4.3.2 Output Mode:

Output mode is not used in this driver and should be left as default.



4.3.3 DeltaV Data Type:

All datasets will be configured as type Floating Point.

4.3.4 DeviceDataType

The following device data types are available.

Table 4

DeviceDataType	Description
0	Read PV Values
1	Read/Write SP Values
2	Read/Write PAR Values
3	Read DI and DO Values
4	Read Mode Values
5	Read Type, Version, and Status values
6	Read RMP Values

4.3.5 Data Start Address and Number of Values

The Start Address for each dataset is not used and can be left as default 0. The Number of values is dependant on the DeviceDataType used. See Table 3 for more information.

4.3.6 Special Data

The following table shows Special Data values used for this driver:

Table 5

Special Data	Description
Special Data 1	When set to 0 (default) the device address will be added to the command string. (A001_IN_PV_00) When set to 1 the device address will be omitted from the command string. (IN_PV_00). If you connected directly to a Lauda Thermostat via RS-232 then this value should be set to 1.
Special Data 2	When set to 0 (default), commands are terminated with a CR. When set to a 1, commands are terminated with a CRLF.
Special Data 3	Unused
Special Data 4	Unused
Special Data 5	Unused

4.3.7 Register Mapping



The following tables show what information each register will hold for a given DeviceDataType:

Table 6a PV Values (Read Only)

Register	Value
1	Bath Temperature
2	Regulated Temperature
3	External Temperature Pt100
4	External Temperature Analog Input
5	Bath Temperature in 0.001C
6	External Temperature Pt100 in 0.001C

Table 6b SP Values

Register	Value
1	Read/Write Temperature Setpoint
2	Read/Write Pump Power Stage
3	Read Current Overtemperature Switch-off Point (READ ONLY)
4	Read/Write Current Outflow Temperature Limit TiH
5	Read/Write Current Outflow Temperature Limit TiL

Table 6c PAR Values (All Values are Read/Write)

Register	Value
1	Current Xp
2	Current Tn (181 = OFF)
3	Current Tv
4	Current Td
5	Current KpE
6	Current TnE (999 = OFF)
7	Current TvE
8	Current TdE
9	Max Outflow Temperature Limit
10	Current XpF
11	Current TnF (181 = OFF)
12	Current TvF
13	Current TdF
14	Setpoint Offset

Table 6d DI/DO Values (READ-ONLY)

Register	Value
1	Status of Contact Input 1 (0=Open / 1=Closed)
2	Status of Contact Input 2 (0=Open / 1=Closed)
3	Status of Contact Input 3 (0=Open / 1=Closed)
4	State of Contact Output 1 (0=Make-Contact Open / 1=Make-Contact Closed)
5	State of Contact Output 2 (0=Make-Contact Open / 1=Make-Contact Closed)
6	State of Contact Output 3 (0=Make-Contact Open / 1=Make-Contact Closed)

Table 6e Mode Values



Register	Value
1	Read/Write Key Master (0=Free / 1=Inhibited)
2	Read/Write Control (0=Int / 1=Ext Pt100 / 2=Ext. Analog / 3=ext. Serial)
3	Read Standby (0=Unit On / 1=Unit Off) (READ ONLY)
4	Read/Write Keys Command (0=Free / 1=Inhibited)
5	Read/Write Setpoint Offset Source (0=Normal / 1=EXT.PT / 2=EXT.Analog / 3=EXT.Serial)

Table 6f Type Version and Status (READ ONLY)

Register	Value
1	Equipment Type
2	Type of Control System
3	Type of Protection System
4	Type of Command
5	Type of Cooling System
6	Type of Analog Module
7	Type of RS232/RS485 Module
8	Type of Digital Module
9	Equipment Status (0=OK / -1=Error)
10	Error Diagnosis Response

Table 6g RMP Values (READ ONLY)

Register	Value
1	Current Segment Number
2	Set Number of Program
3	Current Program
4	Program to which further instructions apply.
5	Which Program is running Now (0=None)



5 Operational Check

5.1 Scope

The following sections provide some assistance to ensure the interface is working properly.

5.2 Verify Hardware and Software Version Number

The user can verify that the Lauda driver has been installed using the DeltaV Diagnostics tool. The Diagnostics tool will show the Hardware Revision No. (HwRev) and the Software Revision No. (SwRev).

To begin the DeltaV Diagnostic tool select Start-> DeltaV-> Operator-> Diagnostics. In the Diagnostics tool expand the Controller, I/O and then double click on the Programmable Serial Interface Card that has the driver installed.

The following information will be displayed:

:	:	:
HwRev	Hardware Revision	1.10 (or later)
SwRev	Software Revision	2.3 (or later)

5.3 Verify Configuration

- Verify port configuration: The serial port must be enabled. User needs to make sure communication settings such as baud rate, parity, and the number of data bits match the field device settings.
- Verify dataset configuration: The datasets configured must be as shown above.

5.4 Verify I/O Communication With Control Studio

User can create I/O modules in the control studio to verify correct values are being written out. An example module is shipped with the distribution. This module shows methods for writing text to the datasets and also how to handle time.

5.5 Using Diagnostics

- Verify PSIC communication: Select the PSIC on Diagnostics and press the right mouse button. Select Display Real -Time Statistics from the drop down menu. If the Programmable Serial Interface Card is functioning then the user will see the Valid Responses counter and the Async and/or Sync Transactions counters incrementing. There will not be any error counting up.



M Y N A H™

POWERFUL SOLUTIONS FOR DIGITAL PLANTS

- Verify port statistics: Select the Port on the Programmable Serial Interface Card and press the right mouse button. Then select Display Port Statistics from the drop down menu. Verify that the port communications statistics are being displayed properly and are counting as expected for the protocol's functionality.
- Verify dataset values: Select a dataset and press the right mouse button. Select View Dataset Registers from the Drop down window. Verify that the dataset values are displayed as expected.

5.6 LED Indication

The Yellow LED for the port should be on solid when all communications on that port are valid. The Yellow LED should be blinking if there is some valid communications and some communications with errors on that port. The Yellow LED should be OFF if there are no valid communications on that port.



6 DeltaV–Field Device Electrical Interface

The electrical interface between DeltaV and field devices conforms to the RS-232 and RS-422/485 standards.

Each PSIC has 2 ports, which function independently. The distance between the serial card and the field device can be as much as 5000 feet, per the RS-422/485 standard. When using RS-232, the distance is limited to 50 feet. Section 6.1 shows the pin assignments for the PSIC serial terminal block.

6.1 Pin Assignments for DeltaV PSIC

RS-232 Standard

Table 6

Terminal Number	Signal Description
1	Port 1 - Isolated Ground (GND)
2	Unused
3	Port 1 – Transmit Data (TxD)
4	Unused
5	Port 1 – Receive Data (RxD)
6	Unused
7	Port 1 – Data Terminal Ready (DTR)
8	Port 1 – Data Set Ready (DSR)
9	Port 2 - Isolated Ground (GND)
10	Unused
11	Port 2 – Transmit Data (TxD)
12	Unused
13	Port 2 – Receive Data (RxD)
14	Unused
15	Port 2 – Data Terminal Ready (DTR)
16	Port 1 – Data Set Ready (DSR)



RS-422/485 Half Duplex Standard

Table 7

Terminal Number	Signal Description
1	Port 1 – Isolated Ground (GND)
2	Port 1 - Data +
3	Unused
4	Port 1 - Data -
5	Unused
6	Unused
7	Unused
8	Unused
9	Port 2 – Isolated Ground (GND)
10	Port 2 – Data +
11	Unused
12	Port 2 - Data -
13	Unused
14	Unused
15	Unused
16	Unused

RS-422/485 Full Duplex Standard

Table 8

Terminal Number	Signal Description
1	Port 1 – Isolated Ground (GND)
2	Port 1 – TxD +
3	Unused
4	Port 1 – TxD -
5	Unused
6	Port 1 – RxD +
7	Unused
8	Port 1 – RxD -
9	Port 2 – Isolated Ground (GND)
10	Port 2 – TxD +
11	Unused
12	Port 2 – TxD -
13	Unused
14	Port 2 – RxD +
15	Unused
16	Port 2 – RxD -



6.2 Wiring Connections

In general, the figure below shows the connections between the Field Device and the PSIC termination block. For additional DeltaV cabling information, please refer to the DeltaV Books Online documentation. For Lauda Thermostat cabling/jumper information, refer to YACE0072/21.04.04 Lauda Proline Low-Temperature Thermostats Manual..

RS232

Term Block - RS-232 Port1

Lauda RS232 Interface

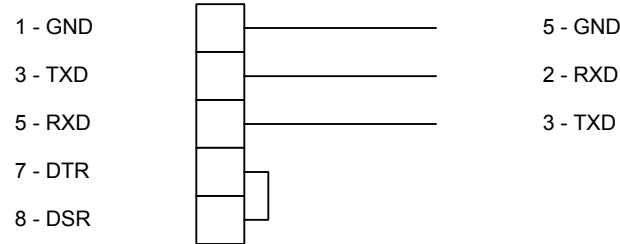

RS485

Term Block - RS-422 Full Duplex Port1

Lauda RS485 Interface

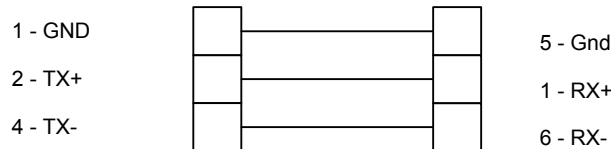



M Y N A H™

POWERFUL SOLUTIONS FOR DIGITAL PLANTS

7 Technical Support

For technical support or to report a defect, please give Mynah Technologies a call at (636) 681-1555. If a defect is discovered, please document it in as much detail as possible and then fax your report to us at (636) 681-1660.

For Product functionality questions, ask for the people in the following order:

1. David Story
2. Tony Kerr

For Commercial issues, ask for people in the following order:

1. Martin Berutti
2. Jane Wagner

You can also send us your questions via e-mail. Our address is:

support@mynah.com

Thank you for using DeltaV.