



**M Y N A H<sup>SM</sup>**

**Toshiba S20  
Programmable Serial Interface Card  
Series 2**

**USER MANUAL**

**Rev. P1.10**

**July, 2005**

DeltaV is a trademark of Emerson Process Management, Inc © Emerson Process Management, Inc. 1998, 1999.  
All rights reserved.

Printed in the U.S.A.

While this information is presented in good faith and believed to be accurate, MYNAH Technologies does not guarantee satisfactory results from reliance upon such information. *Nothing contained herein is to be construed as a warranty or guarantee, express or implied, regarding the performance, merchantability, fitness or any other matter with respect to the products*, nor as a recommendation to use any product or process in conflict with any patent. MYNAH Technologies reserves the right, without notice, to alter or improve the designs or specifications of the products described herein.



# **1 INTRODUCTION**

## **1.1 Scope**

This document is the Users Manual for the Toshiba S20 communications driver firmware for the Emerson Process Management (EPM) DeltaV Control System. The driver will run in the DeltaV Series 2 Programmable Serial Interface Card (PSIC). The reader should be familiar with EPM's DeltaV PSIC and connected Toshiba S20 devices.

## **1.2 Document Format**

This document is organized as follows:

**Table 1**

<b>Introduction</b>	Describes the scope and purpose of this document.
<b>Theory of Operation</b>	Provides a general functional overview of the Toshiba S20 Driver.
<b>Downloading Firmware</b>	Describes downloading procedures for the driver firmware on to the DeltaV PSIC.
<b>Configuration Information</b>	Describes procedures and guidelines for configuring the DeltaV PSIC.
<b>Operational Check</b>	Provides tips and assistance to ensure PSIC is properly setup and configured.
<b>DeltaV–Field Device Electrical Interface</b>	Describes the electrical interface between DeltaV and the Toshiba devices. Also describes the cable pin assignments for the Toshiba RS-232C ports.
<b>Technical Support</b>	Describes who to call if you need assistance.
<b>Example</b>	Describes how to configure a device with input and output datasets.



**1.3 System Specifications**

The following table lists the minimum system requirements for the driver:

<b>Protocol Compatibility and Reference documents</b>	The communication protocol used will be the Toshiba SIF Communication Protocol described in TOSLINE-S20 SIF Station User's Manual Section 5.2
<b>Software Requirements</b>	DeltaV System Software (Release 6.3.2 or later) installed on a hardware-appropriate Windows workstation configured as a ProfessionalPlus for DeltaV  Serial Interface Port License (VE4102)
<b>Minimum DeltaV Hardware Requirements</b>	DeltaV Serial Interface Series 2, Hardware PN: 12P2506X022  DeltaV M3, M5, MD or Series 2 MD Controller, Power Supply and 2 wide controller carrier  DeltaV 8 wide I/O card carrier



## 2 THEORY OF OPERATION

The Programmable Serial Interface Card (PSIC) has 2 ports which can be configured for RS-232 communications with external devices.

For communications with Toshiba S20 devices, the PSIC will connect to the RS-232C port on the back of the S20 device. See the TOSLINE-S20 User's Manual for additional information on S20 networking.

Below is an example of a possible setup.

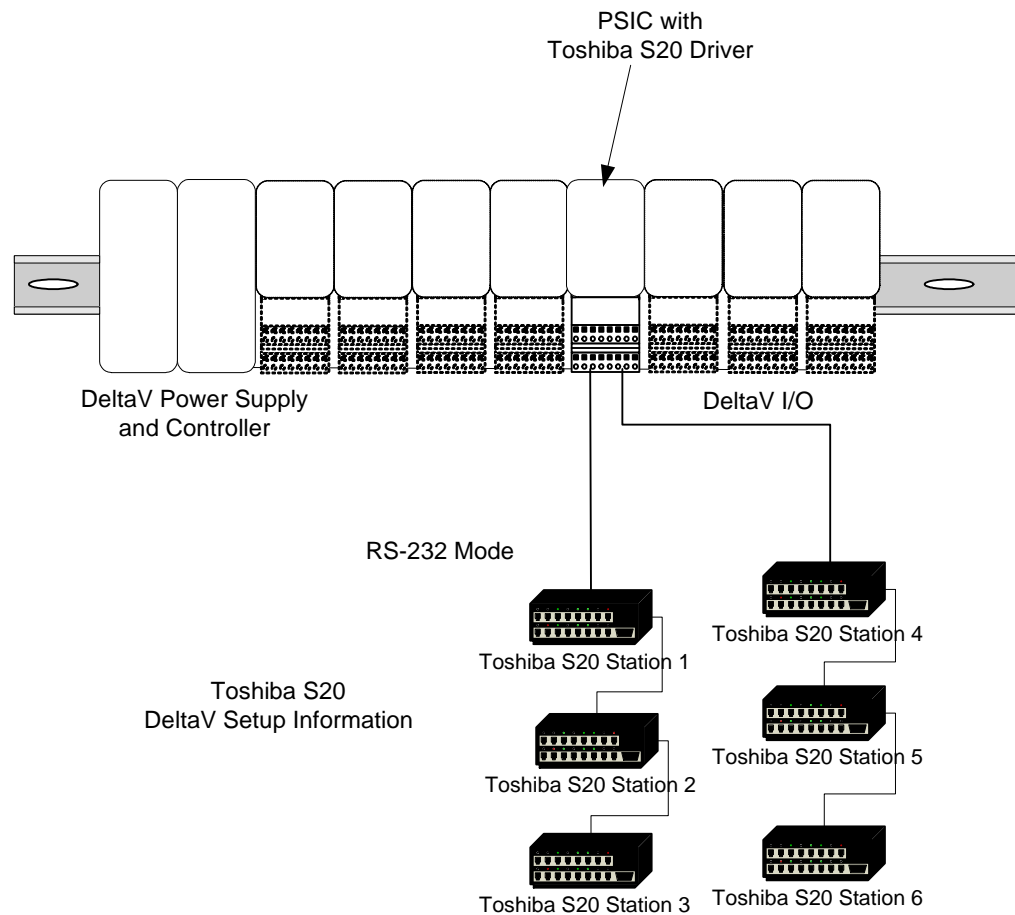



### 3 Downloading the firmware

The driver software distribution comprises 14 files, distributed on a CD. These files must be copied to the DeltaV directory on your ProPlus Workstation. The path is:

**\\DeltaV\ctl\ProgSerial\S2ToshibaS20**

Note that you will have to create the \S2ToshibaS20 subdirectory. The following files will be copied:

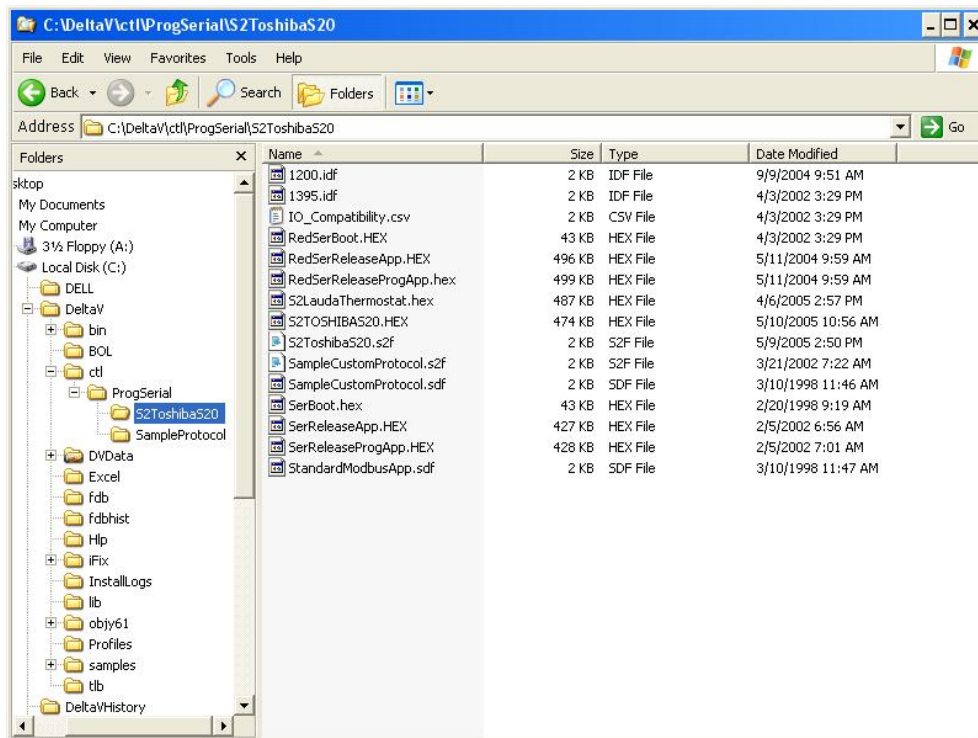



After copy completion, you are ready to program (or upgrade) the Programmable Serial Card with the supplied custom driver software. The steps are as follows:

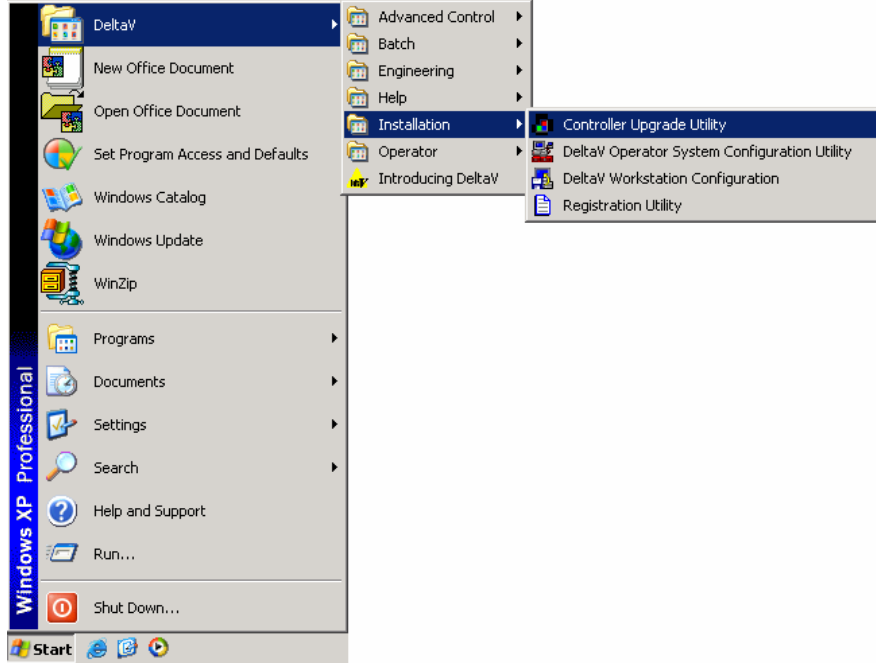

1. Click on the Start button and select DeltaV-> Installation-> Controller Upgrade Utility as shown below, and the following dialog will appear:

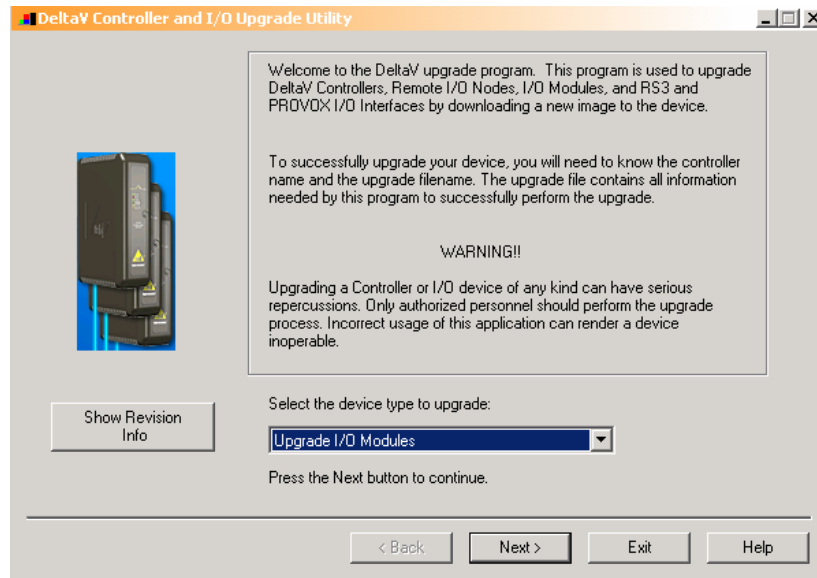

2. Choose Upgrade I/O Modules from the drop down menu and click Next.

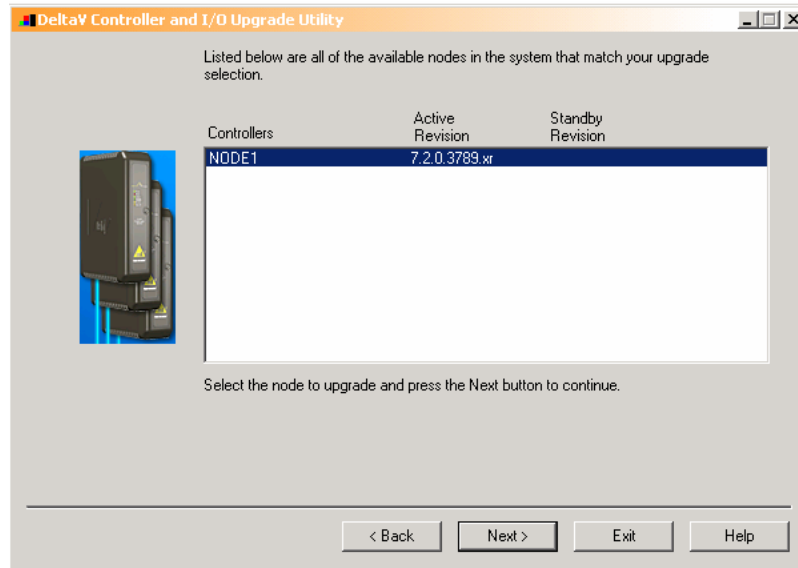

3. The above dialog will appear, listing all the available Controllers in your network. From this dialog, select the appropriate Controller and then Click Next.
4. The following dialog will appear, listing all the I/O modules in your selected Controller. The shown list of I/O modules is an example only. Your list will be different.

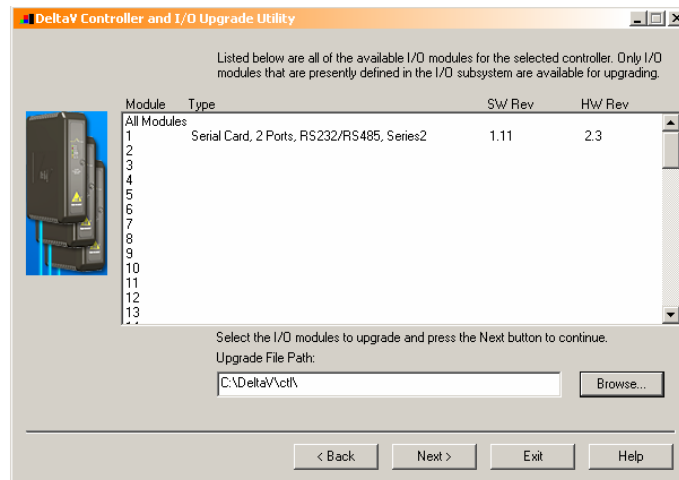

**Note: The first time a standard Serial card is upgraded to the Toshiba Driver, the dialog will be as shown below. When upgrading an existing Programmable Serial Card, skip Steps 4, 5 and 6, and go to Step 7.**

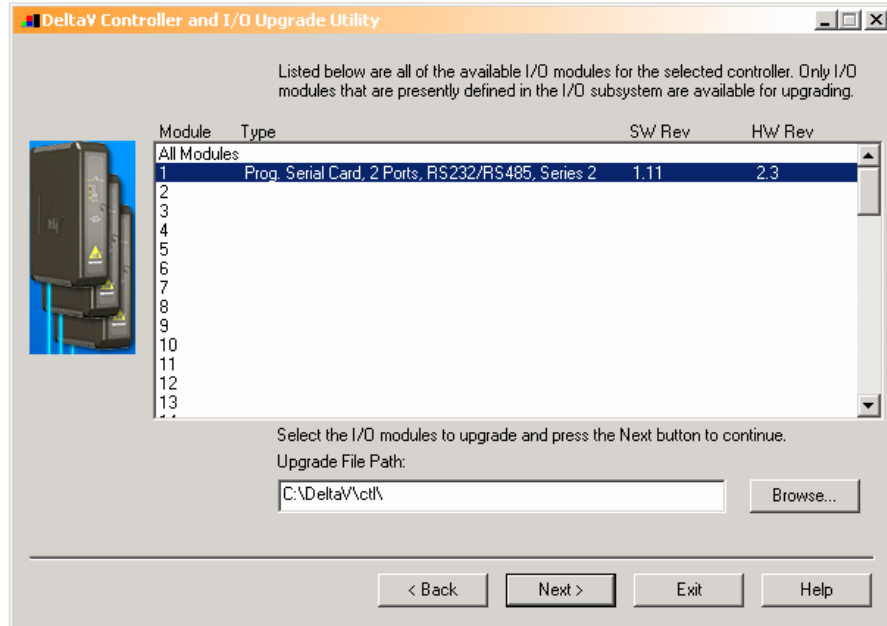

5. Click the Browse button and select the DeltaV path as shown below, and then click Ok. Note that the disk drive could be C or D.

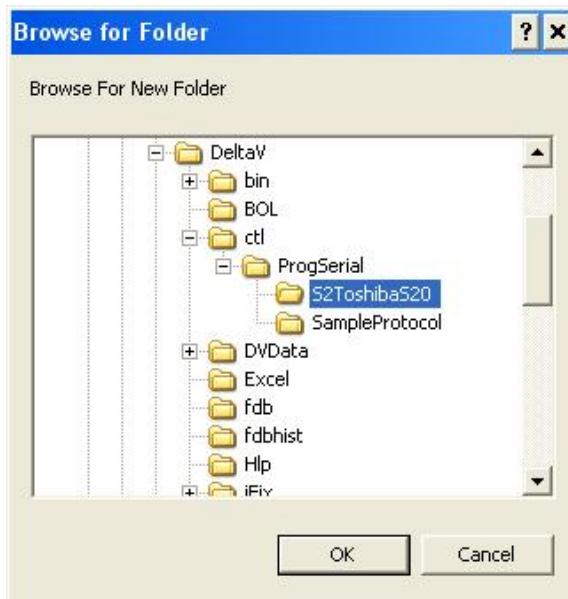



- 6. Select the I/O module again as shown below and then click Next. Go to Step 9.

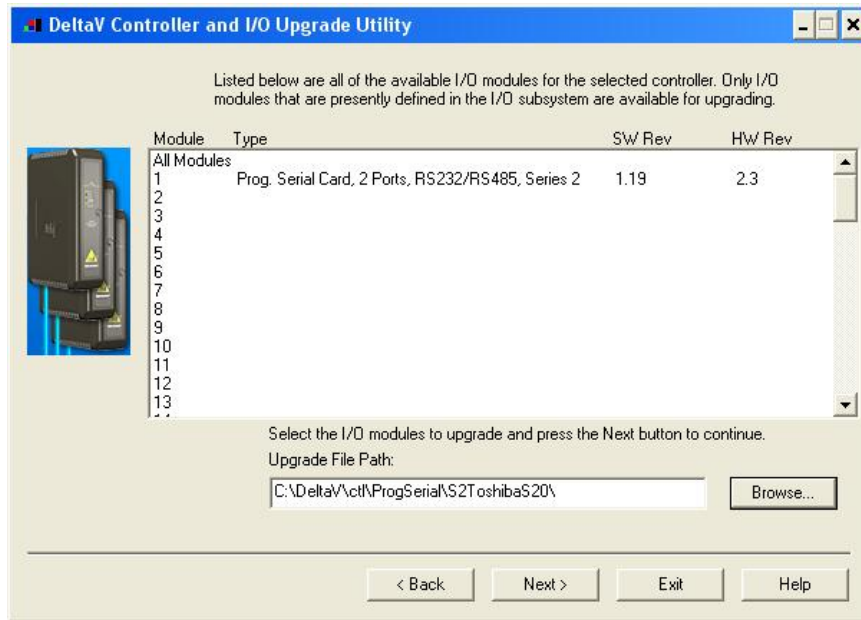

- 7. If you are upgrading an existing Programmable Serial Card, the dialog will be as shown below. From this dialog, select the Programmable Serial Card I/O Module in the list.

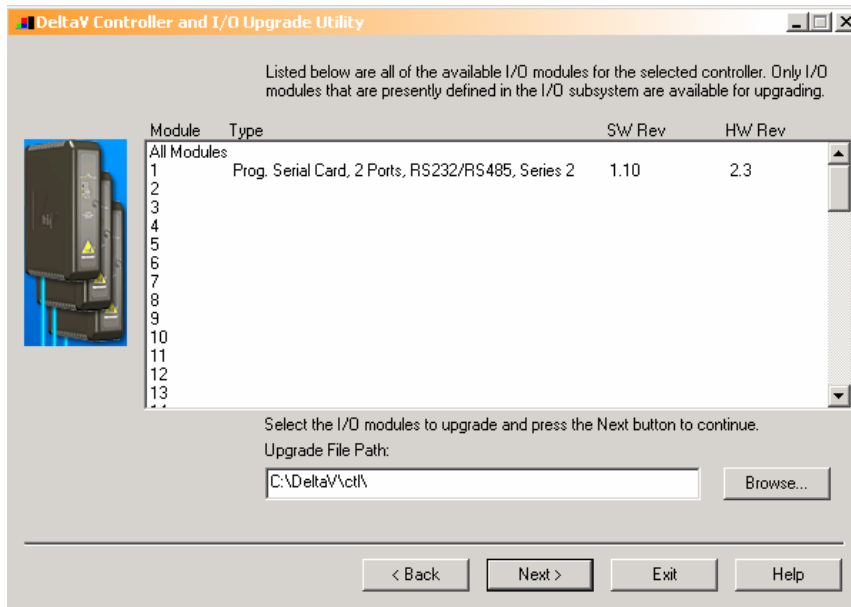

For example, we will select I/O Module 1. This will give you a dialog, from which you will select the file path to where the driver software is located. This path will be:

**\\DeltaV\ctl\ProgSerial \S2ToshibaS20\**

Once you are in the specified directory, you will need to select the following file:



**S2ToshibaS20.S2F**

This is shown in the following dialog.

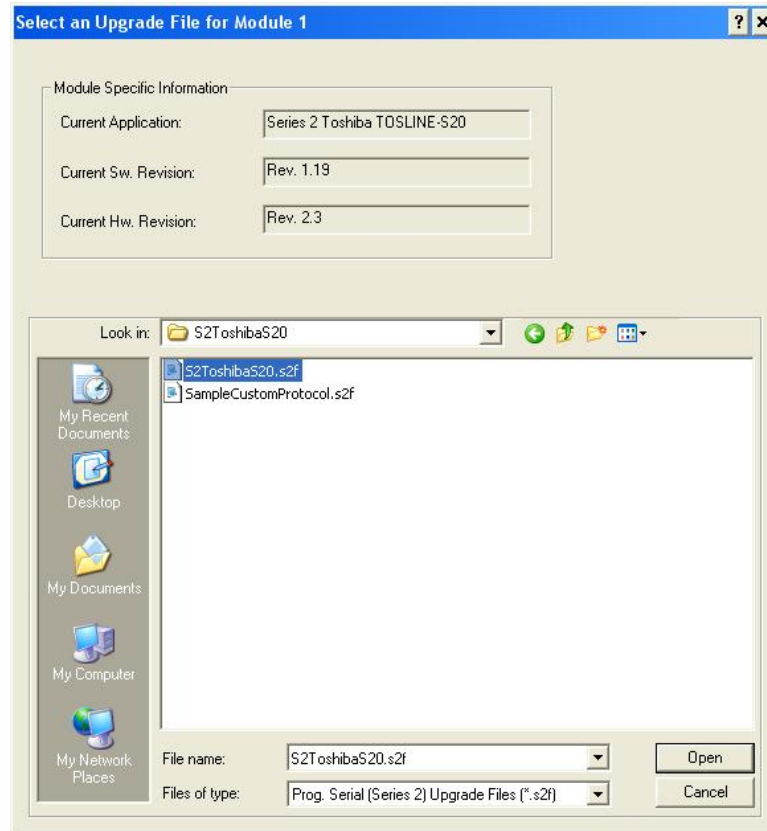



- 8. After selecting the .S2F file, Click on Open. This dialog will close and you will be back to the following:

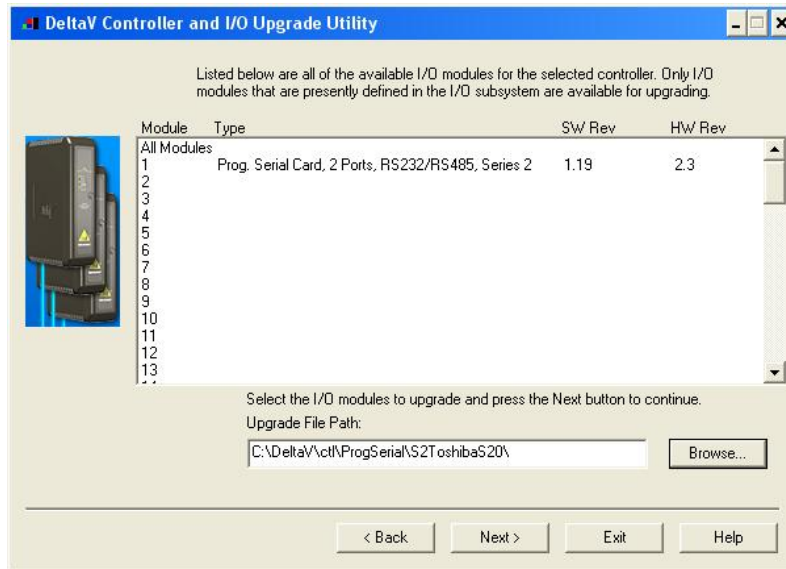

- 9. In this dialog, Click Next again. You will get the following dialog, confirming the Controller and I/O Module to program.

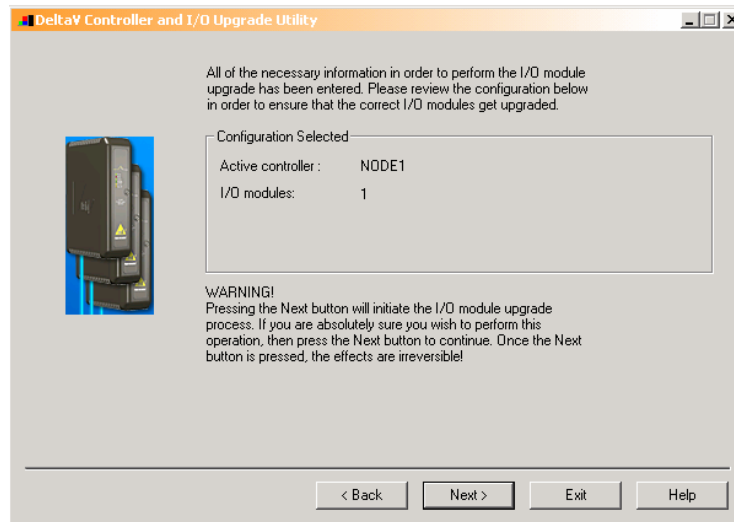

- 10. Click Next and the I/O Module upgrade process will begin. After completion, you will receive the following dialog, indicating success.

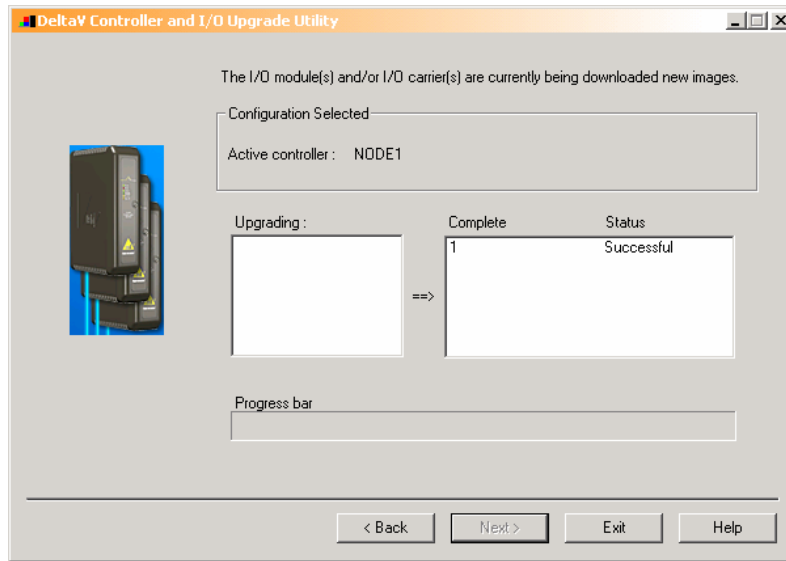

11. This completes the I/O Module upgrade process.



## 4 CONFIGURATION INFORMATION

Under each port, there exist 16 datasets. The user may configure the 16 datasets in any way. Below is a description of the commands available from our TOSLINE driver and how to configure the datasets for each command.

### 4.1 Port Configuration

The port should be configured as master. Retry Count, Message Timeout, and Transmit Delay can be left as default or changed at the users' discretion. The Port Type should be defined as RS232. RS-485 Half and Full Duplex are not supported by the Toshiba S20. The Baud Rate, Parity, and Stop Bits should match the settings in the Toshiba devices. The default settings on the Toshiba TOSLINE-S20 are Baud: 9600, Parity: Even, Stop Bits: 1, Byte size: 8.

### 4.2 Device Configuration

One device should be configured for each Toshiba S20 connected to a given port. The device address should match the Station Number of the S20 you wish to communicate with. The number of devices available depend on the users data requirements. 16 datasets are available on each port.

### 4.3 Dataset Configuration

#### 4.3.1 Data Direction:

There are 5 types of datasets that can be defined under a device. Those types are listed below in section 4.3.4. Only Device Data Type 0 (Scan Data) can be defined as output. All other types will be defined as input.

#### 4.3.2 Output Mode and Readback:

For Device Data Type 0 only. Output mode of 0 will write the entire dataset out each time a single value is changed. Output mode of 1 will write only the value that is changed in the dataset. Readback will designate where the registers in the dataset will be read back from the Toshiba during each scan.

#### 4.3.3 DeltaV Data Type:

Since values stored in the Toshiba S20 are represented by up to 4 ASCII characters for a largest possible value of 9999. 16-Bit Unsigned Integers should be used for all types.



**4.3.4 DeviceDataType**

<b>DeviceDataType</b>	<b>DESCRIPTION</b>
0	Scan Data
1	Online Map Read
2	Scan Healthy Map Read
3	Down Information Read
4	Station Status Read

**4.3.5 Data Start Address and Number of Values**

<b>DeviceDataType</b>	<b>Start Address</b>	<b>Number of Values</b>
0	Address of the beginning of the Scan Data to read.	Number of values to read.
1	Start Address is not used for this type.	10 Values should be used to read the Station Status and the Online and Standby Maps
2	Start address will not be used in the standard way for this type. Below is how the start addresses will be mapped.  0 = Scan Healthy Map 0 to 15 1 = Scan Healthy Map 16 to 31 2 = Scan Healthy Map 32 to 47 3 = Scan Healthy Map 48 to 63	18 Values should be defined to hold the Station Status and the Healthy Map being scanned.
3	Start Address is not used for this type.	3 values should be defined to hold the Station Status and Down Information Code
4	Start Address is not used for this type.	2 values should be defined to hold the station status.

**4.3.6 Special Data**

Special Data 1 will be setup for CRC checking. When Special Data 1 is equal to 0 the CRC will be added to each outgoing message. When Special Data 1 is equal to 1 the CRC will be omitted from the outgoing message. All other Special Data values can be left as default.



## **5 Operational Check**

### **5.1 Scope**

The following sections provide some assistance to ensure the interface is working properly.

### **5.2 Verify Hardware and Software Version Number**

The user can verify that the Toshiba S20 driver has been installed using the DeltaV Diagnostics tool. The Diagnostics tool will show the Hardware Revision No. (HwRev) and the Software Revision No. (SwRev).

To begin the DeltaV Diagnostic tool select Start-> DeltaV-> Operator-> Diagnostics. In the Diagnostics tool expand the Controller, I/O and then double click on the Programmable Serial Interface Card that has the driver installed.

The following information will be displayed:

HwRev	Hardware Revision	1.10 (or later)
SwRev	Software Revision	2.3 (or later)

### **5.3 Verify Configuration**

Verify port configuration: The serial port must be enabled. User needs to make sure communication settings such as baud rate, parity, and number of data bits match the Toshiba S20 settings.

Verify device configuration: User must check for the proper device address is entered. The TOSLINE Station Number should match the Device Address.

Verify Dataset configuration.

### **5.4 Verify I/O Communication With Control Studio**

User can create I/O modules in the control studio to verify correct values are read and written between the foreign device into the PSIC. For input data, the values should be changed in the foreign device and verified that the new data are correctly reported. For output data, change the values in the controller and then verify that the values are transferred to the foreign device.

To assign a Dataset and a register in the Dataset to an I/O module, follow these steps:

1. Double click the IO\_IN/IO\_OUT parameter for the module. This brings up the IO\_IN/IO\_OUT Property window.
2. Click on the Browse button. This brings up the Browse window.
3. Click on the Object\_Type drop down list, select All. This displays all the Dataset tags.
4. Double click on the desired Dataset tag. This assigns the tag to the module and closes the Browse window.
5. Choose the desired register in the Parameter drop down list.
6. Click the OK button.



For output modules, user also needs to change the MODE parameter to Manual for Normal Mode and Target.

## **5.5 Using Diagnostics**

Verify PSIC communication: Select the PSIC on Diagnostics and press the right mouse button. Select Display Real -Time Statistics from the drop down menu. If the Programmable Serial Interface Card is functioning then the user will see the Valid Responses counter and the Async and/or Sync Transactions counters incrementing. There will not be any error counting up.

Verify port statistics: Select the Port on the Programmable Serial Interface Card and press the right mouse button. Then select Display Port Statistics form the drop down menu. Verify that the port communications statistics are being displayed properly and are counting as expected for the protocol's functionality.

Verify dataset values: Select a dataset and press the right mouse button. Select View Dataset Registers from the Drop down window. Verify that the dataset values are displayed as expected.

## **5.6 LED Indication**

The Yellow LED for the port should be on solid when all communications on that port are valid. The Yellow LED should be blinking if there is some valid communications and some communications with errors on that port. The Yellow LED should be OFF if there are no valid communications on that port.

## 6 DeltaV–Field Device Electrical Interface

The electrical interface between DeltaV and field devices conforms to the RS-232 and RS-422/485 standards.

Each PSIC has 2 ports. The Toshiba S20 devices operate in RS232 mode only.

### 6.1 Pin Assignments for DeltaV PSIC

#### RS-232 Standard

Table 6

Terminal Number	Signal Description
1	Port 1 - Isolated Ground (GND)
2	Unused
3	Port 1 – Transmit Data (TxD)
4	Unused
5	Port 1 – Receive Data (RxD)
6	Unused
7	Port 1 – Data Terminal Ready (DTR)
8	Port 1 – Data Set Ready (DSR)
9	Port 2 - Isolated Ground (GND)
10	Unused
11	Port 2 – Transmit Data (TxD)
12	Unused
13	Port 2 – Receive Data (RxD)
14	Unused
15	Port 2 – Data Terminal Ready (DTR)
16	Port 1 – Data Set Ready (DSR)

### 6.2 Wiring Connections

The figure below shows the connections between the RS-232C port on the Toshiba S20 and Port 1 on the Serial Card Termination Block.

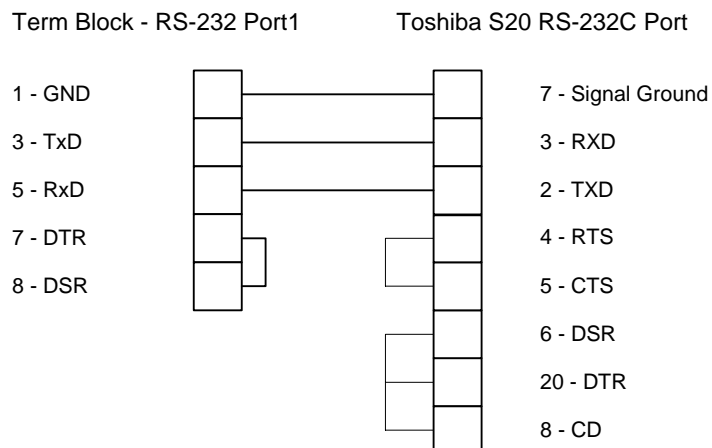



**M Y N A H™**

**POWERFUL SOLUTIONS FOR DIGITAL PLANTS**

## **7 Technical Support**

For technical support or to report a defect, please give Mynah Technologies a call at (636) 681-1555. If a defect is discovered, please document it in as much detail as possible and then fax your report to us at (636) 681-1660.

For Product functionality questions, ask for the people in the following order:

1. David Story
2. Tony Kerr

For Commercial issues, ask for people in the following order:

1. Martin Berutti
2. Jane Wagner

You can also send us your questions via e-mail. Our address is:

[support@mynah.com](mailto:support@mynah.com)

Thank you for using DeltaV.