



M Y N A HSM

**Watson-Marlow 520DU(N)
Programmable Serial Interface Card
Series 2**

USER MANUAL

Rev. P1.10

July, 2005

DeltaV is a trademark of Emerson Process Management, Inc © Emerson Process Management, Inc. 1998, 1999.
All rights reserved.

Printed in the U.S.A.

While this information is presented in good faith and believed to be accurate, MYNAH Technologies does not guarantee satisfactory results from reliance upon such information. *Nothing contained herein is to be construed as a warranty or guarantee, express or implied, regarding the performance, merchantability, fitness or any other matter with respect to the products*, nor as a recommendation to use any product or process in conflict with any patent. MYNAH Technologies reserves the right, without notice, to alter or improve the designs or specifications of the products described herein.



1 INTRODUCTION

1.1 Scope

This document is the Design Document for the Watson-Marlow communications driver firmware for the Emerson Process Management (EPM) DeltaV Control System. The driver will run in the DeltaV Series 2 Programmable Serial Interface Card (PSIC). The reader should be familiar with EPM's DeltaV PSIC and connected Watson-Marlow devices.

1.2 Document Format

This document is organized as follows:

Table 1

Introduction	Describes the scope and purpose of this document.
Theory of Operation	Provides a general functional overview of the Watson-Marlow Driver.
Downloading Firmware	Describes downloading procedures for the driver firmware on to the DeltaV PSIC.
Configuration Information	Describes procedures and guidelines for configuring the DeltaV PSIC.
Operational Check	Provides tips and assistance to ensure PSIC is properly setup and configured.
DeltaV–Field Device Electrical Interface	Describes the electrical interface between DeltaV and the Watson-Marlow devices. Also describes the cable pin assignments for RS-485.
Technical Support	Describes who to call if you need assistance.
Example	Describes how to configure a device with input and output datasets.



1.3 System Specifications

The following table lists the minimum system requirements for the driver:

Protocol Compatibility and Reference documents	The communication protocol used will be the Watson-Marlow RS485 Communication Protocol described in Watson-Marlow manual: m-520dun-4x-gb-01
Software Requirements	DeltaV System Software (Release 6.3.2 or later) installed on a hardware-appropriate Windows workstation configured as a ProfessionalPlus for DeltaV Serial Interface Port License (VE4102)
Minimum DeltaV Hardware Requirements	DeltaV Serial Interface Series 2, Hardware PN: 12P2506X022 DeltaV M3, M5, MD or Series 2 MD Controller, Power Supply and 2 wide controller carrier DeltaV 8 wide I/O card carrier



2 THEORY OF OPERATION

The Programmable Serial Interface Card (PSIC) has 2 ports which can be configured for RS-232, RS-422/RS-485 Half Duplex or RS-422/RS-485 Full Duplex communications with external devices.

For communications with Watson-Marlow devices, the PSIC will connect to the RS485 port located at J10 on the rear circuit board shown in section 22.14 of the 520DuN manual. The driver will utilize both ports for communications. Up to 8 devices can be connected to each port. This is illustrated below.

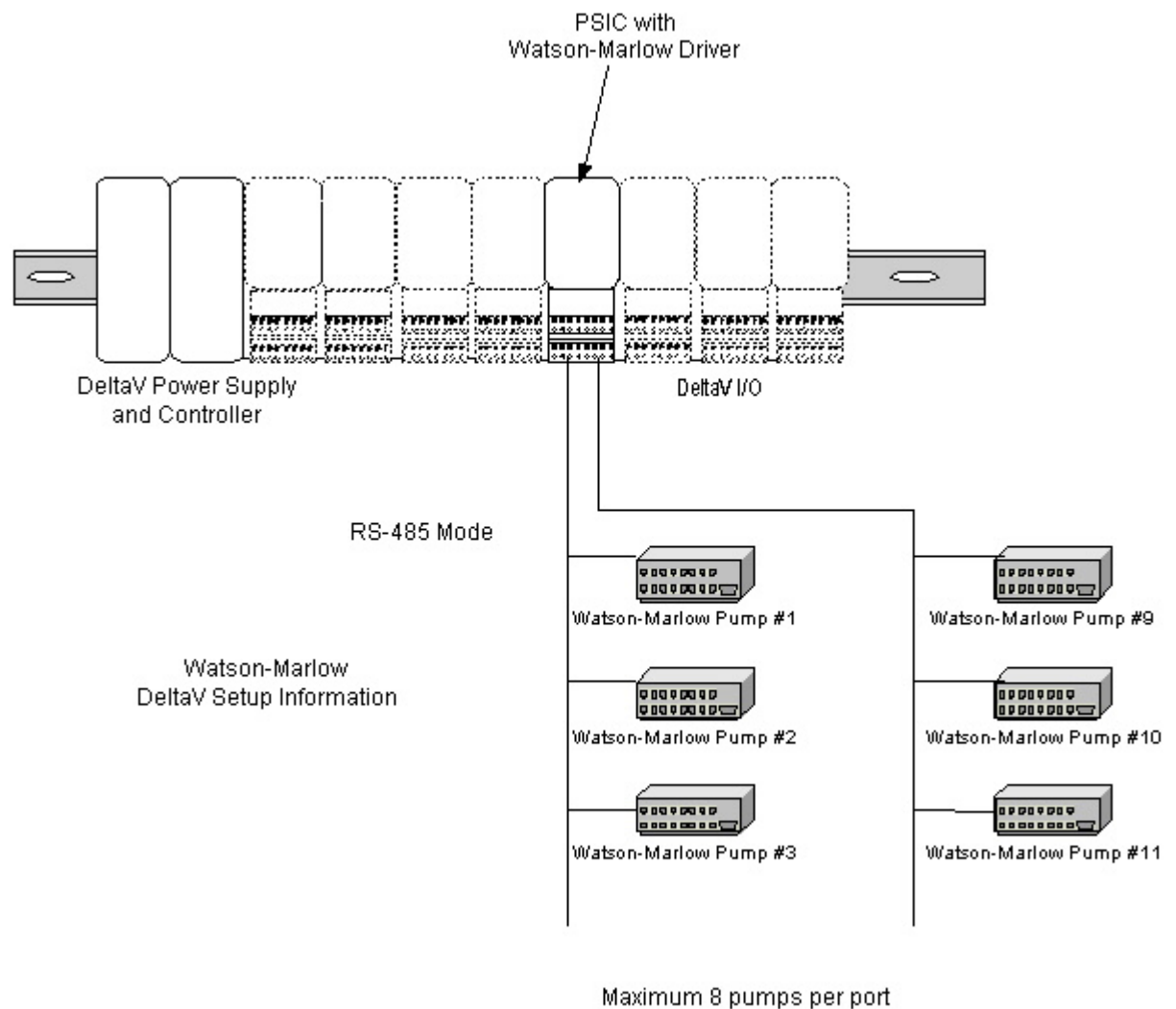

3 Downloading the firmware

The driver software distribution comprises 14 files, distributed on a CD. These files must be copied to the DeltaV directory on your ProPlus Workstation. The path is:

\DeltaV\ctl\ProgSerial\S2WatsonMarlow

Note that you will have to create the \S2WatsonMarlow subdirectory. The following files will be copied:

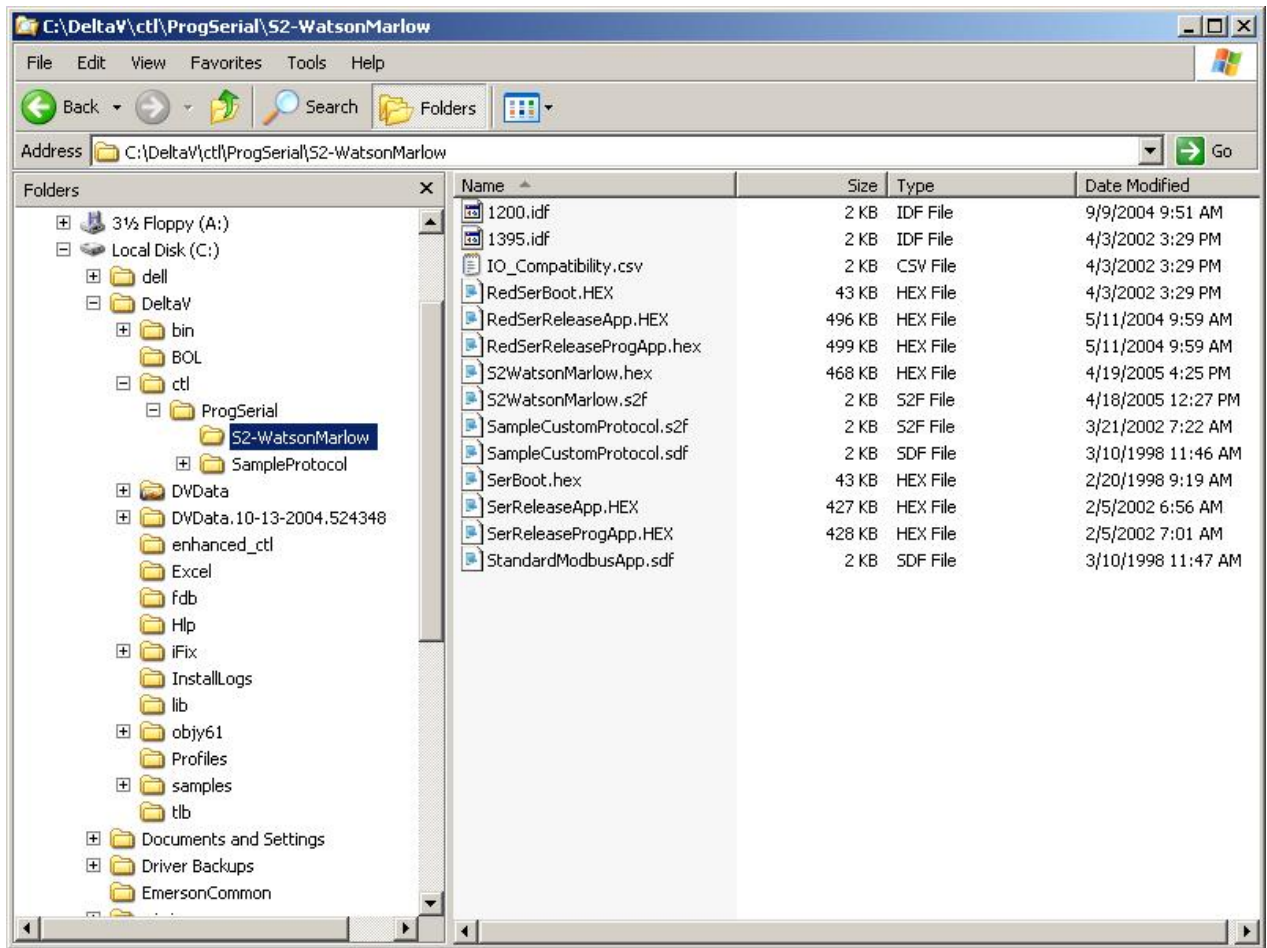



After copy completion, you are ready to program (or upgrade) the Programmable Serial Card with the supplied custom driver software. The steps are as follows:

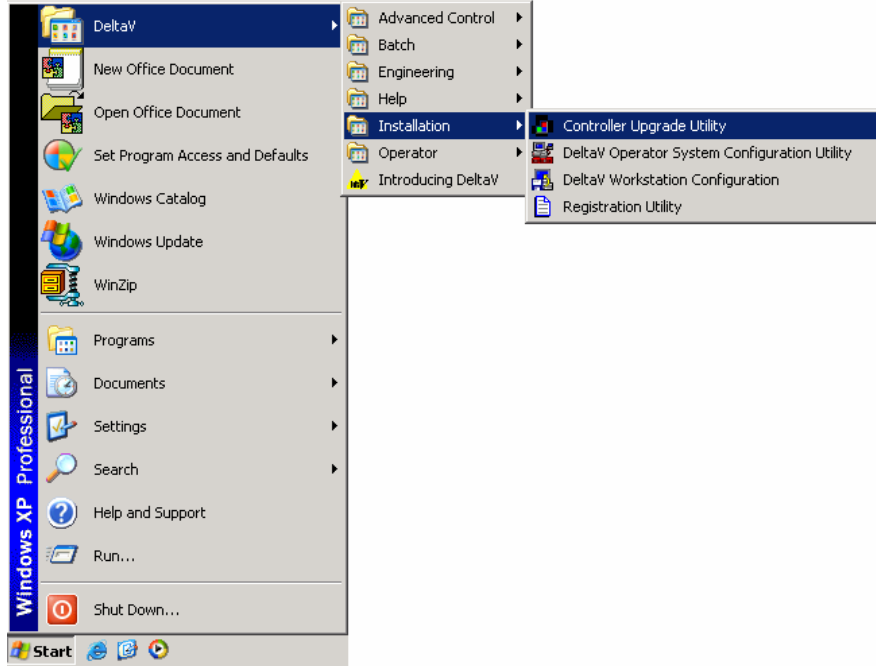

1. Click on the Start button and select DeltaV-> Installation-> Controller Upgrade Utility as shown below, and the following dialog will appear:

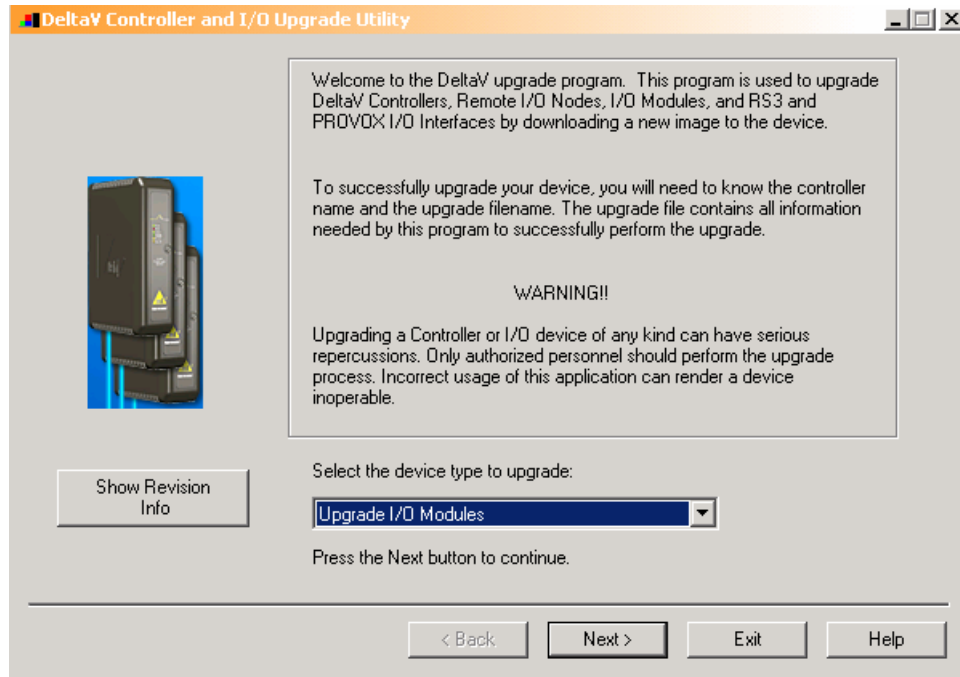

2. Choose Upgrade I/O Modules from the drop down menu and click Next.

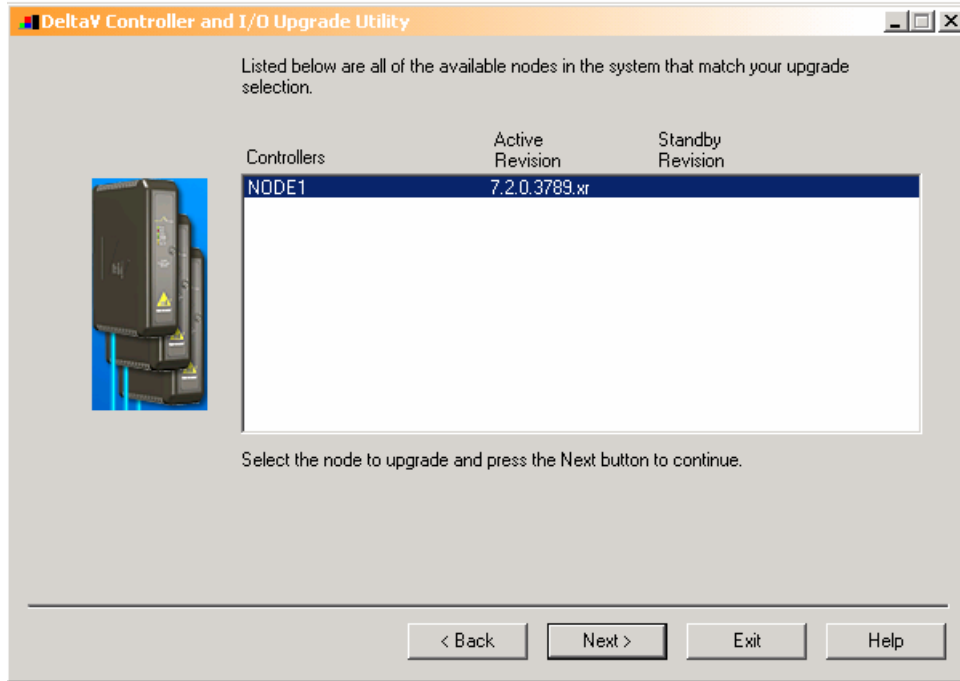

3. The above dialog will appear, listing all the available Controllers in your network. From this dialog, select the appropriate Controller and then Click Next.

4. The following dialog will appear, listing all the I/O modules in your selected Controller. The shown list of I/O modules is an example only. Your list will be different.

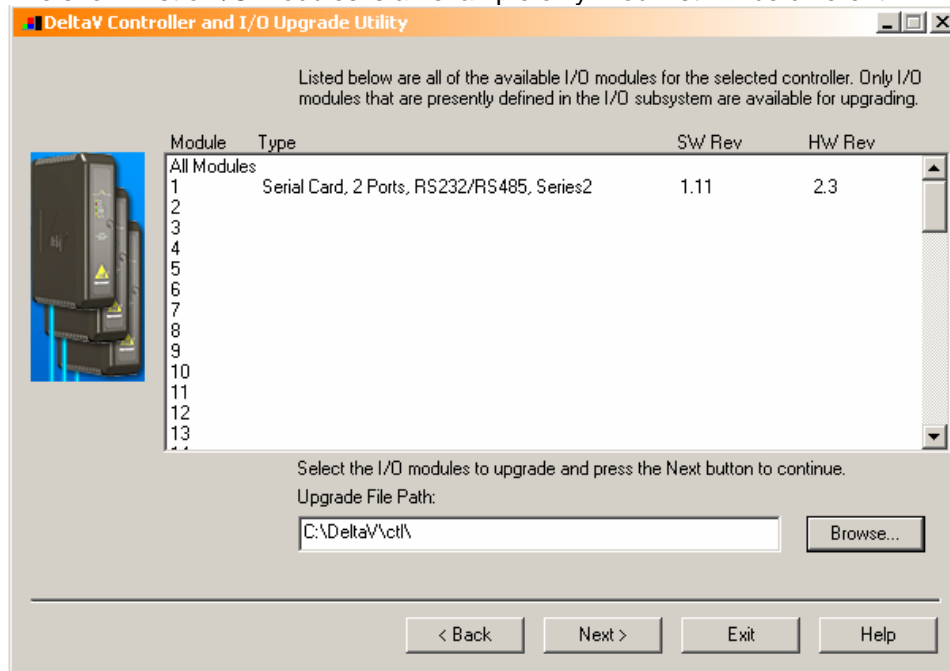

Note: The first time a standard Serial card is upgraded to the Watson Marlow Driver, the dialog will be as shown below. When upgrading an existing Programmable Serial Card, skip Steps 4, 5 and 6, and go to Step 7.

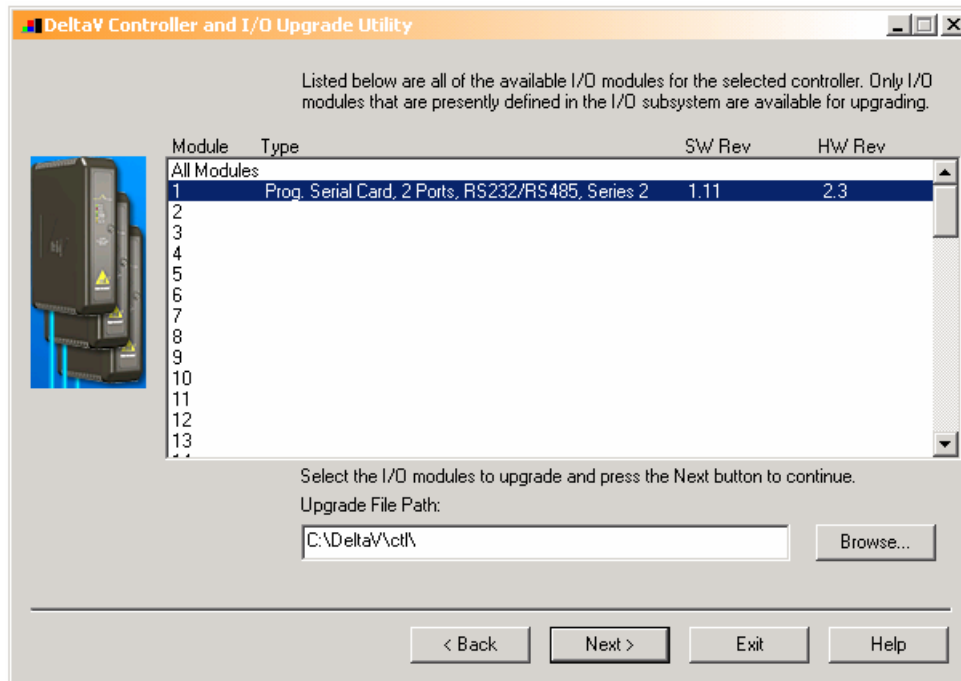

5. Click the Browse button and select the DeltaV path as shown below, and then click Ok. Note that the disk drive could be C or D.

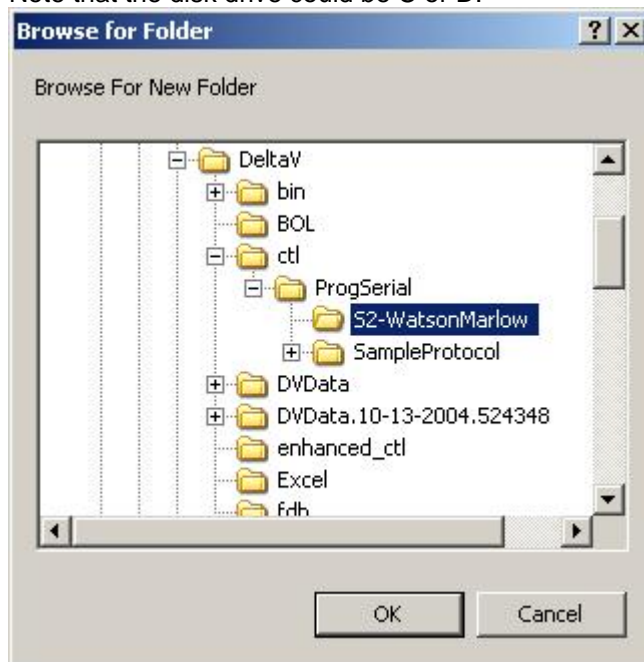



6. Select the I/O module again as shown below and then click Next. Go to Step 9.

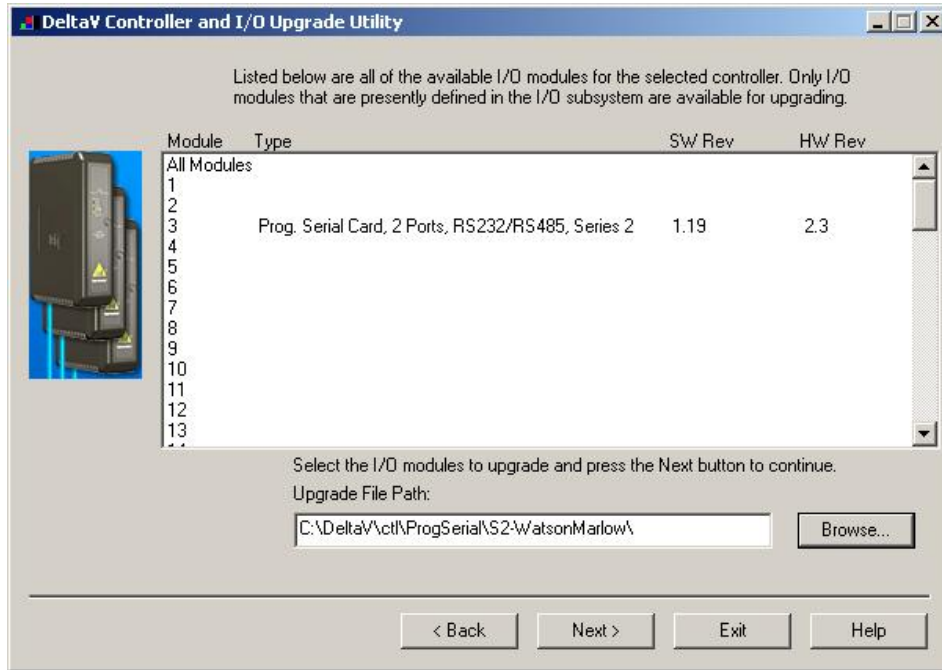

7. If you are upgrading an existing Programmable Serial Card, the dialog will be as shown below. From this dialog, select the Programmable Serial Card I/O Module in the list.

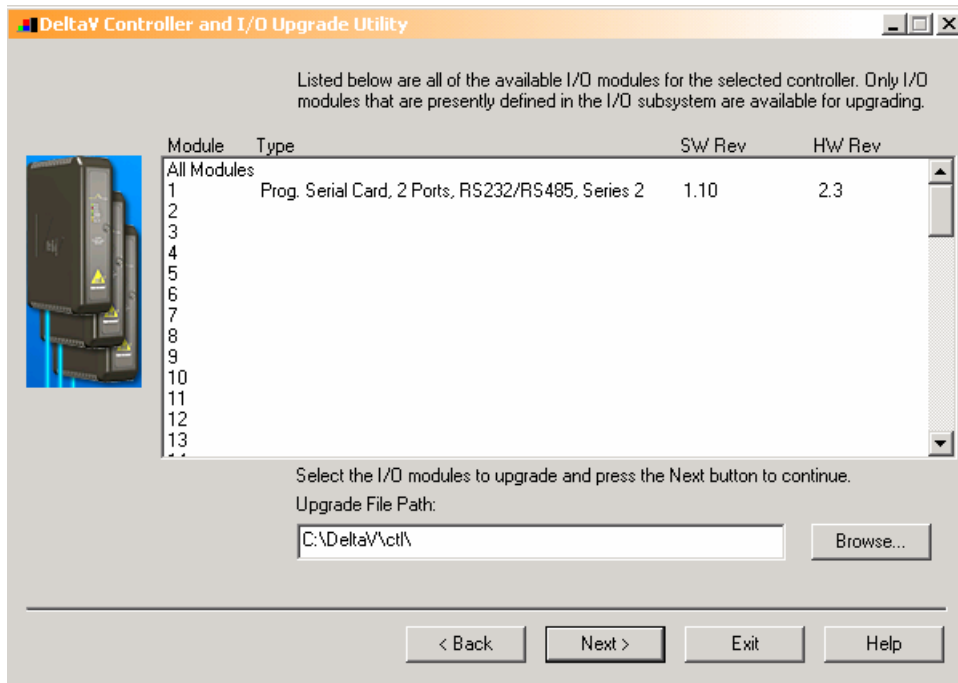



For example, we will select I/O Module 1. This will give you a dialog, from which you will select the file path to where the driver software is located. This path will be:

\\DeltaVct1\ProgSerial \S2WatsonMarlow

Once you are in the specified directory, you will need to select the following file:

S2WatsonMarlow.S2F

This is shown in the following dialog.

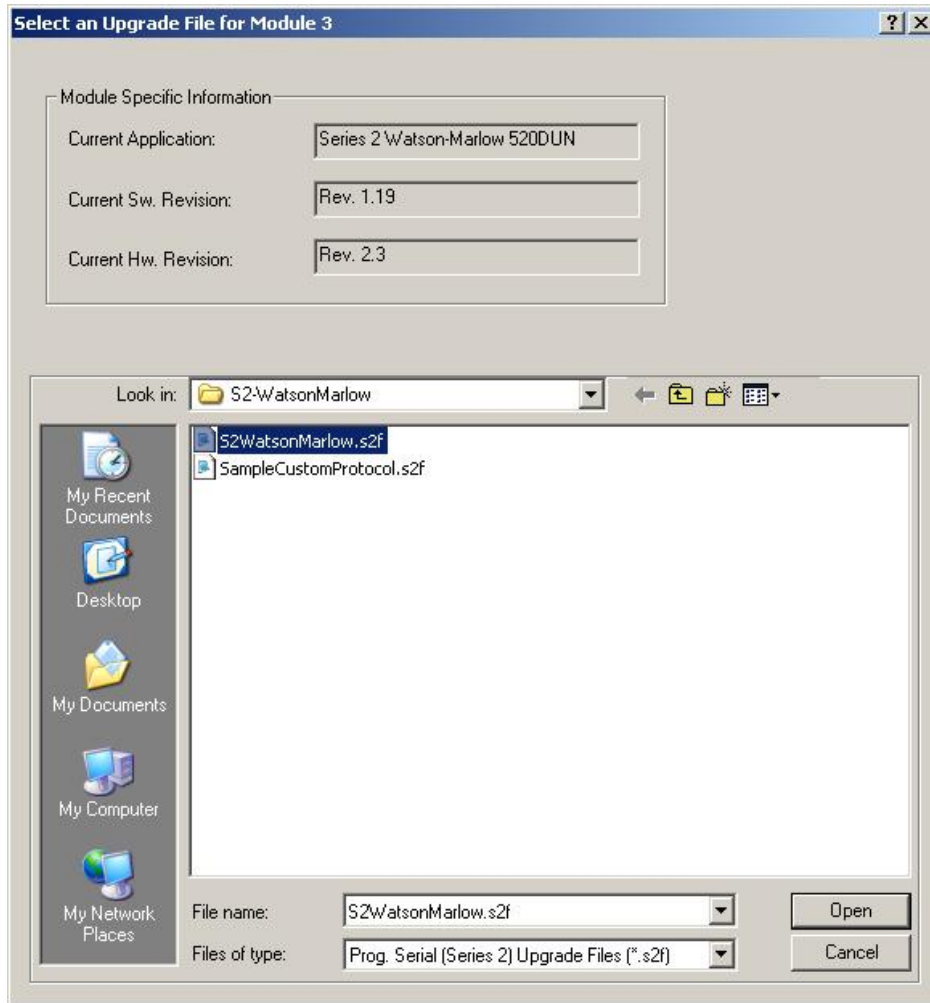



8. After selecting the .S2F file, Click on Open. This dialog will close and you will be back to the following:

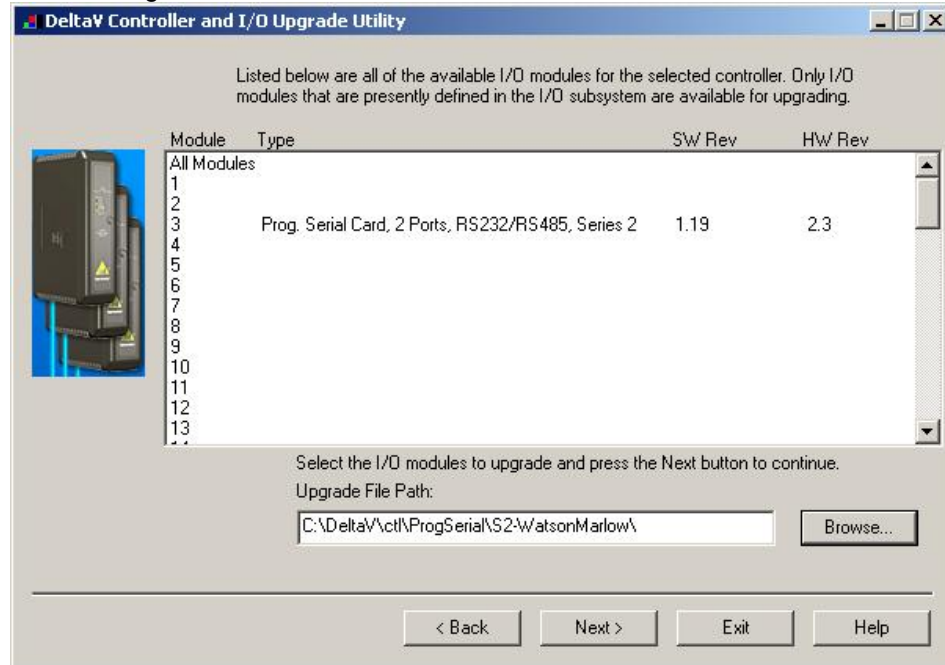

9. In this dialog, Click Next again. You will get the following dialog, confirming the Controller and I/O Module to program.

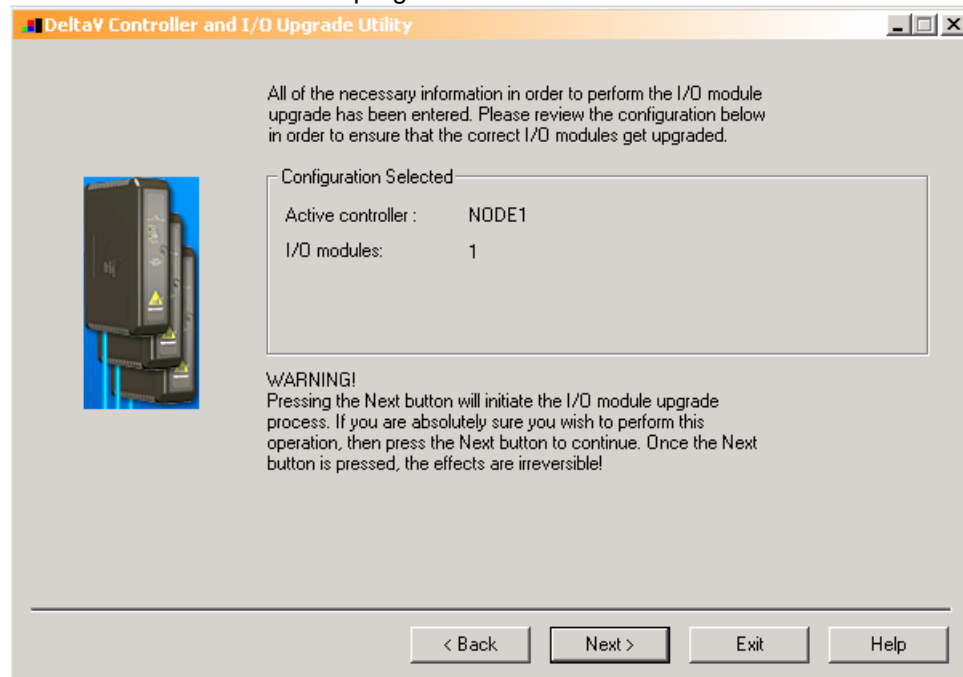

10. Click Next and the I/O Module upgrade process will begin. After completion, you will receive the following dialog, indicating success.

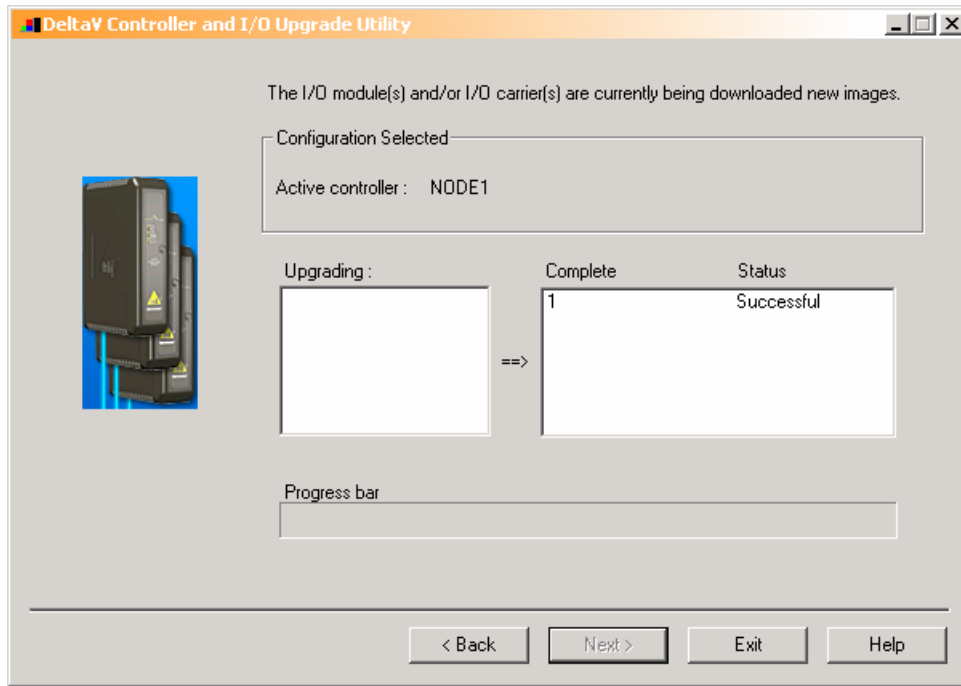

11. This completes the I/O Module upgrade process.



4 **CONFIGURATION INFORMATION**

Under each port, there exist 16 datasets. Each attached Watson-Marlow pump will need 2 datasets for operation. This allows for up to 8 pumps per port. Under the port a Device will be created for each attached pumped. The device address should match the Pump Number assigned to Watson-Marlow Pump. Under each device, 2 datasets will be defined that will handle reading values and writing commands.

The figure below shows and example Watson-Marlow setup:

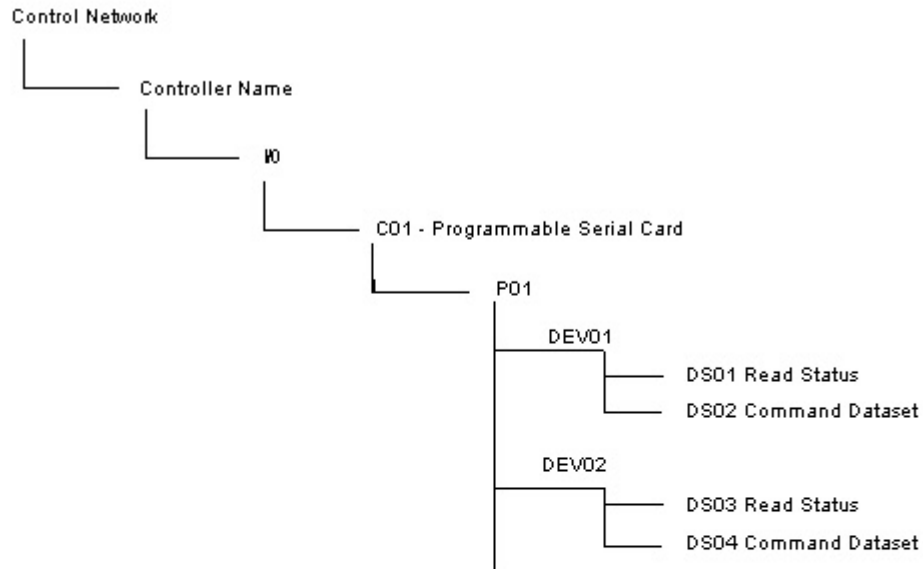

4.1 **Port Configuration**

The port should be configured as master. Retry Count, Message Timeout, and Transmit Delay can be left as default or changed at users discretion. The Port Type should be defined as RS485 Half-Duplex. Communications using RS-232, and RS-485 Full Duplex are not supported by the Watson-Marlow Pump driver. The Baud Rate and Stop Bits should match the settings in the Watson-Marlow devices. Parity should be set to “None” and Data Bits to “8”.



4.2 Device Configuration

One device should be configured for each Watson-Marlow Pump connected to a given port. The device address should match the Pump Number of the pump you wish to communicate with. Up to 8 devices may be configured per port for a total of 16 per PSIC.

4.3 Dataset Configuration

4.3.1 Data Direction:

Two datasets will be defined under each device. The first dataset will be an Input Dataset. The second will be an Output Dataset.

4.3.2 Output Mode and Readback:

Output mode will not be used in this driver and can be left as default. Readback mode will also not be used and should not be checked.

4.3.3 DeltaV Data Type:

The DeltaV Data Type for both datasets should be Floating Point.

4.3.4 DeviceDataType

The Device Data type will not be used in this driver and can be left as default.

4.3.5 Special Data

The Special Data values (1-5) will not be used in this driver and can be left as default.

4.3.6 Register Mappings

Table 1 – Dataset 1 Register Mapping

REGISTER	DESCRIPTION
1	Pump Type
2	ml/rev
3	Pump Head
4	Tube Size
5	Speed
6	Clockwise = 0 Counterclockwise = 1
7	Pump Number
8	Tachometer Count
9	Stopped = 0 Running = 1

Table 2 – Dataset 2 Register Mapping

REGISTER	DESCRIPTION
1	Send Command
2	Command Code
3	Command Argument 1
4	Command Argument 2
5	Status

Dataset 2 will be used to send commands to the Watson-Marlow Pumps. Below are the steps taken to write a command to the pump.

Step 1: Write Command Code into Register 2

Table 3 – Command Codes

Command Code	Description
1	Set and Run One Dose (nDO)
2	Clear Tachometer Count (nTC)
3	Set Speed (nSP)
4	Increment Speed by 1 RPM (nSI)
5	Decrement Speed by 1 RMP (nSD)
6	Start Running (nGO)
7	Stop Running (nST)
8	Change Direction (nRC)
9	Set Direction to Clockwise (nRR)
10	Set Direction to Counterclockwise (nRT)

Step 2: If the command requires arguments, enter them into Register 3 and 4. Only Command Code 1 and 3 require arguments.

Step 3: Write a value of 1 into Register 1 to send the command out to the Watson-Marlow.



EXAMPLE 1: Setting Speed

- Step 1: Enter a value of 3 into Register 2 (3 = Set Speed as shown in table 3)
- Step 2: Enter the new speed value in Register 3
- Step 3: Enter a value of 1 into register 1 to send the command to the pump.

EXAMPLE 2: Set and Run One Dose

- Step 1: Enter a value of 1 into Register 2
- Step 2: Enter the number of Pulses into Register 3
- Step 3: Optionally enter the drip tacho pulses into register 4
- Step 4: Enter a value of 1 into Register 1 to send the command to the pump.

EXAMPLE 3: Set Direction to Clockwise

- Step 1: Enter a value of 9 into Register 2
- Step 2: Enter a value of 1 into Register 1 to send the command to the pump.



5.0 Operational Check

5.1 Scope

The following sections provide some assistance to ensure the interface is working properly.

5.2 Verify Hardware and Software Version Number

The user can verify that the Watson-Marlow driver has been installed using the DeltaV Diagnostics tool. The Diagnostics tool will show the Hardware Revision No. (HwRev) and the Software Revision No. (SwRev).

To begin the DeltaV Diagnostic tool select Start-> DeltaV-> Operator-> Diagnostics. In the Diagnostics tool expand the Controller, I/O and then double click on the Programmable Serial Interface Card that has the driver installed.

The following information will be displayed:

:	:	:
HwRev	Hardware Revision	1.10 (or later)
SwRev	Software Revision	2.3 (or later)

5.3 Verify Configuration

- Verify port configuration: The serial port must be enabled. User needs to make sure communication settings such as baud rate, parity, and number of data bits match the Watson-Marlow pump settings.
- Verify device configuration: User must check for the proper device address is entered. The Watson-Marlow Pump number should match the Device Address.
- Verify Dataset configuration: The first Dataset should be defined as Input, Floating Point, with 9 values. The second should be Output (WITHOUT READBACK), Floating Point, with 5 Values.



5.4 Verify I/O Communication With Control Studio

- User can create I/O modules in the control studio to verify correct values are read and written between the foreign device into the PSIC. For input data, the values should be changed in the foreign device and verified that the new data are correctly reported. For output data, change the values in the controller and then verify that the values are transferred to the foreign device.
- To assign a Dataset and a register in the Dataset to an I/O module, follow these steps:
 1. Double click the IO_IN/IO_OUT parameter for the module. This brings up the IO_IN/IO_OUT Property window.
 2. Click on the Browse button. This brings up the Browse window.
 3. Click on the Object_Type drop down list, select All. This displays all the Dataset tags.
 4. Double click on the desired Dataset tag. This assigns the tag to the module and closes the Browse window.
 5. Choose the desired register in the Parameter drop down list.
 6. Click the OK button.
- For output modules, user also needs to change the MODE parameter to Manual for Normal Mode and Target.

5.5 Using Diagnostics

- Verify PSIC communication: Select the PSIC on Diagnostics and press the right mouse button. Select Display Real -Time Statistics from the drop down menu. If the Programmable Serial Interface Card is functioning then the user will see the Valid Responses counter and the Async and/or Sync Transactions counters incrementing. There will not be any error counting up.
- Verify port statistics: Select the Port on the Programmable Serial Interface Card and press the right mouse button. Then select Display Port Statistics form the drop down menu. Verify that the port communications statistics are being displayed properly and are counting as expected for the protocol's functionality.
- Verify dataset values: Select a dataset and press the right mouse button. Select View Dataset Registers from the Drop down window. Verify that the dataset values are displayed as expected.

5.6 LED Indication

The Yellow LED for the port should be on solid when all communications on that port are valid. The Yellow LED should be blinking if there is some valid communications and some communications with errors on that port. The Yellow LED should be OFF if there are no valid communications on that port.



6 DeltaV–Field Device Electrical Interface

The electrical interface between DeltaV and field devices conforms to the RS-232 and RS-422/485 standards.

Each PSIC has 2 ports. The Watson-Marlow pumps operate in RS485 Half-Duplex mode only.

6.1 Pin Assignments for DeltaV PSIC

RS-422/485 Half Duplex Standard

Table 7

Terminal Number	Signal Description
1	Port 1 – Isolated Ground (GND)
2	Port 1 - Data +
3	Unused
4	Port 1 - Data -
5	Unused
6	Unused
7	Unused
8	Unused
9	Port 2 – Isolated Ground (GND)
10	Port 2 – Data +
11	Unused
12	Port 2 - Data -
13	Unused
14	Unused
15	Unused
16	Unused



6.2 Wiring Connections

The figure below shows the connections between the Watson-Marlow J10 RS485 port and Port 1 on the Serial Card Termination Block.

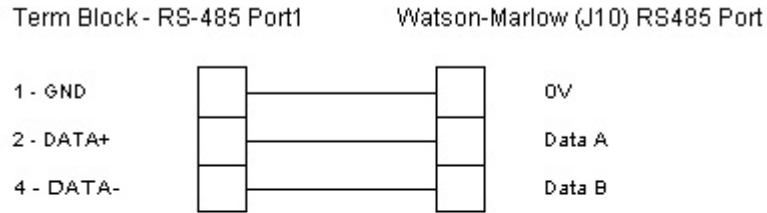



M Y N A H™

POWERFUL SOLUTIONS FOR DIGITAL PLANTS

7 Technical Support

For technical support or to report a defect, please give Mynah Technologies a call at (636) 681-1555. If a defect is discovered, please document it in as much detail as possible and then fax your report to us at (636) 681-1660.

For Product functionality questions, ask for the people in the following order:

1. David Story
2. Tony Kerr

For Commercial issues, ask for people in the following order:

1. Martin Berutti
2. Jane Wagner

You can also send us your questions via e-mail. Our address is:

support@mynah.com

Thank you for using DeltaV.