



M Y N A HSM

**MTS Level Gauge
Programmable Serial Interface Card
Series 2**

USER MANUAL

Rev. P1.10

May 12, 2006

DeltaV is a trademark of Emerson Process Management, Inc © Emerson Process Management, Inc. 1998, 1999. All rights reserved.

Printed in the U.S.A.

While this information is presented in good faith and believed to be accurate, MYNAH Technologies does not guarantee satisfactory results from reliance upon such information. *Nothing contained herein is to be construed as a warranty or guarantee, express or implied, regarding the performance, merchantability, fitness or any other matter with respect to the products*, nor as a recommendation to use any product or process in conflict with any patent. MYNAH Technologies reserves the right, without notice, to alter or improve the designs or specifications of the products described herein.



1 INTRODUCTION

1.1 Scope

This document is the Design Document for the MTS Level Gauge communications driver firmware for the Emerson Process Management (EPM) DeltaV Control System. The driver will run in the DeltaV Series 2 Programmable Serial Interface Card (PSIC). The reader should be familiar with EPM's DeltaV PSIC and connected MTS Level Gauge devices.

1.2 Document Format

This document is organized as follows:

Table 1: Document Format

Introduction	Describes the scope and purpose of this document.
Theory of Operation	Provides a general functional overview of the MTS Level Gauge Driver.
Downloading Firmware	Describes downloading procedures for the driver firmware on to the DeltaV PSIC.
Configuration Information	Describes procedures and guidelines for configuring the DeltaV PSIC.
Operational Check	Provides tips and assistance to ensure PSIC is properly setup and configured.
DeltaV–Field Device Electrical Interface	Describes the electrical interface between DeltaV and the MTS Level Gauge devices. Also describes the cable pin assignments for RS-485.
Technical Support	Describes who to call if you need assistance.



1.3 System Specifications

The following table lists the minimum system requirements for the driver:

Table 2: Specifications

Protocol Compatibility and Reference documents	The communication protocol used will be the MTS Level Gauge RS485 Communication Protocol described in the MTS Level Gauge manual. Mynah Functional Requirements Specification: MTS FR REV3 050506.PDF
Software Requirements	DeltaV System Software (Release 6.3.2 or later) installed on a hardware-appropriate Windows workstation configured as a ProfessionalPlus for DeltaV Serial Interface Port License (VE4102)
Minimum DeltaV Hardware Requirements	FRSI DeltaV Serial Interface Series 2, Hardware PN: 12P2506X022 FRSI DeltaV M3, M5, MD or Series 2 MD Controller, Power Supply and 2 wide controller carrier FRSI 8 wide I/O card carrier



2 THEORY OF OPERATION

The Programmable Serial Interface Card (PSIC) has 2 ports which can be configured for RS-232, RS-422/RS-485 Half Duplex or RS-422/RS-485 Full Duplex communications with external devices.

For communications with MTS Level Gauge devices, the PSIC will connect to the RS485 port located on the DDA Analog PCB as illustrated in Figure 9.9 of the MTS Level Gauge manual. The driver will utilize both ports for communications. Up to 80 devices can be connected to each port. This is illustrated below.

The driver runs in Master mode only. By default, the driver will continuously interrogate the MTS Level Gauge for levels and read the temperatures every one-minute to avoid self-heating of the RTD's. The read information will be stored in dataset registers as described below. The normal scan of the levels will be as fast as responses received from the MTS Level Gauge which should be on the order of 1.9 to 3.2 seconds depending on gauge type. The scan rate of the temperatures is 2.9 seconds + 2.7 seconds per RTD.

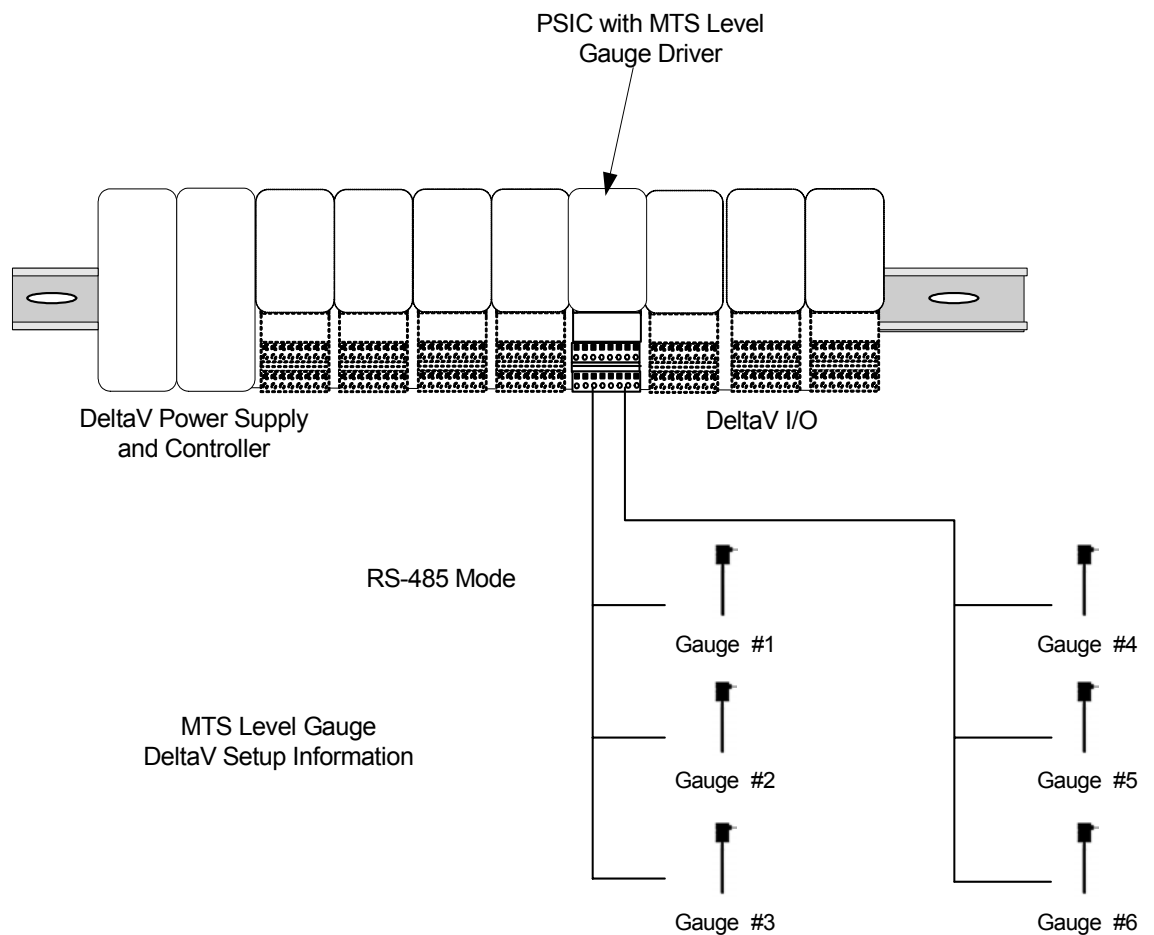



3 Downloading the firmware

The driver software distribution comprises 14 files, distributed on a CD. These files must be copied to the DeltaV directory on your ProPlus Workstation. The path is:

\\DeltaV\ctl\ProgSerial\S2-MTS

Note that you will have to create the \S2-MTS subdirectory. The following files will be copied:

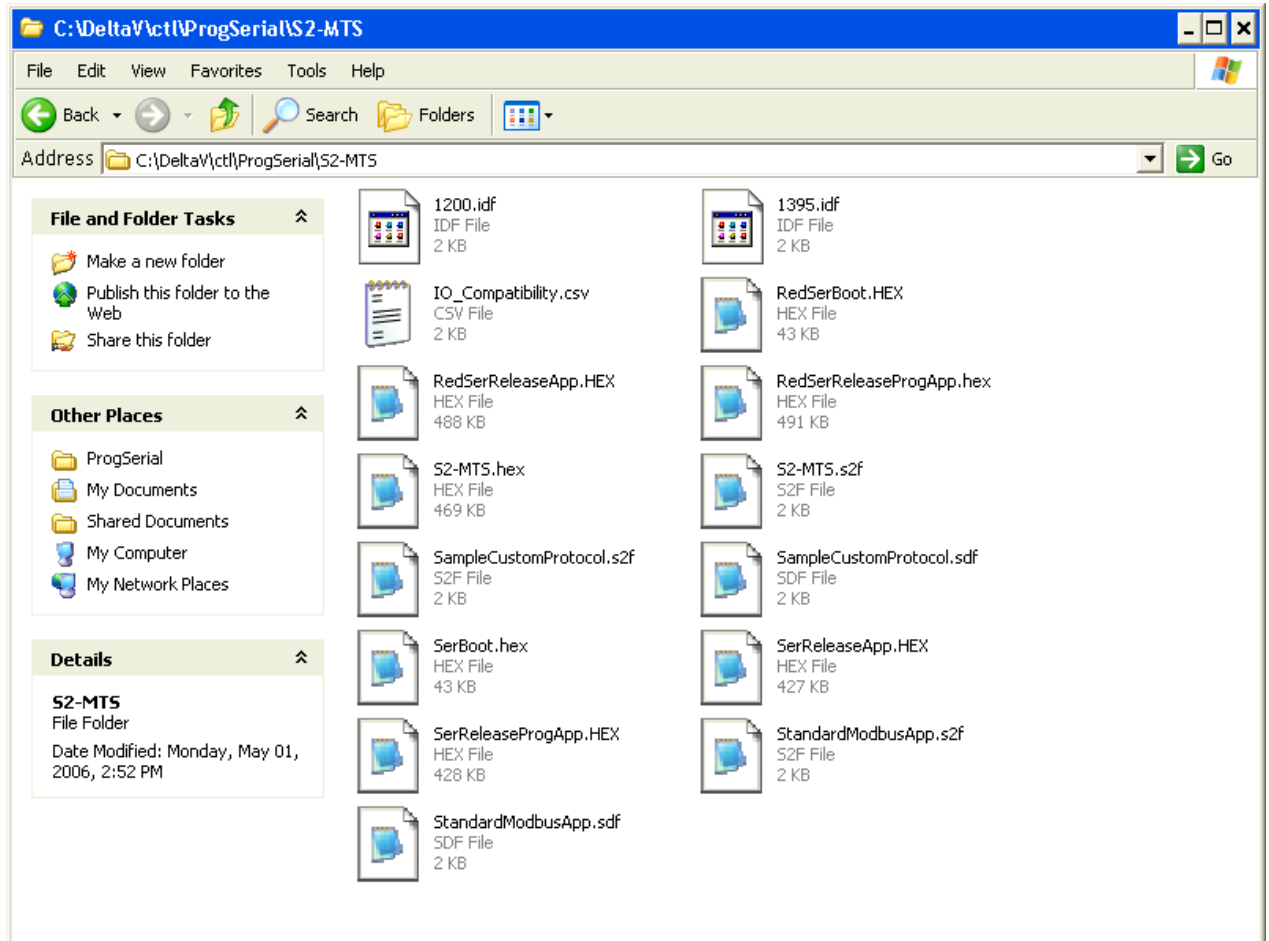



After copy completion, you are ready to program (or upgrade) the Programmable Serial Card with the supplied custom driver software. The steps are as follows:

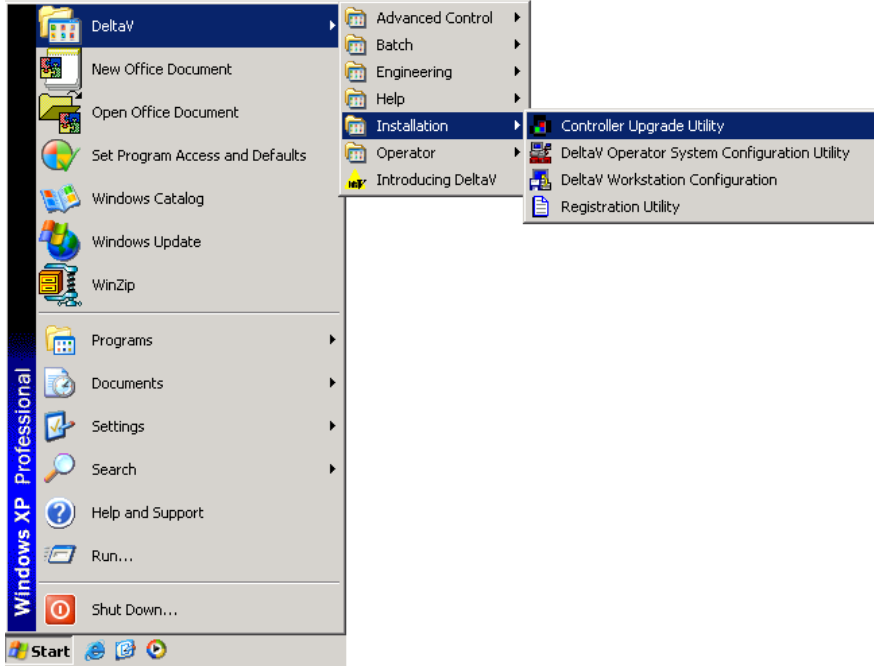

1. Click on the Start button and select DeltaV-> Installation-> Controller Upgrade Utility as shown below, and the following dialog will appear:

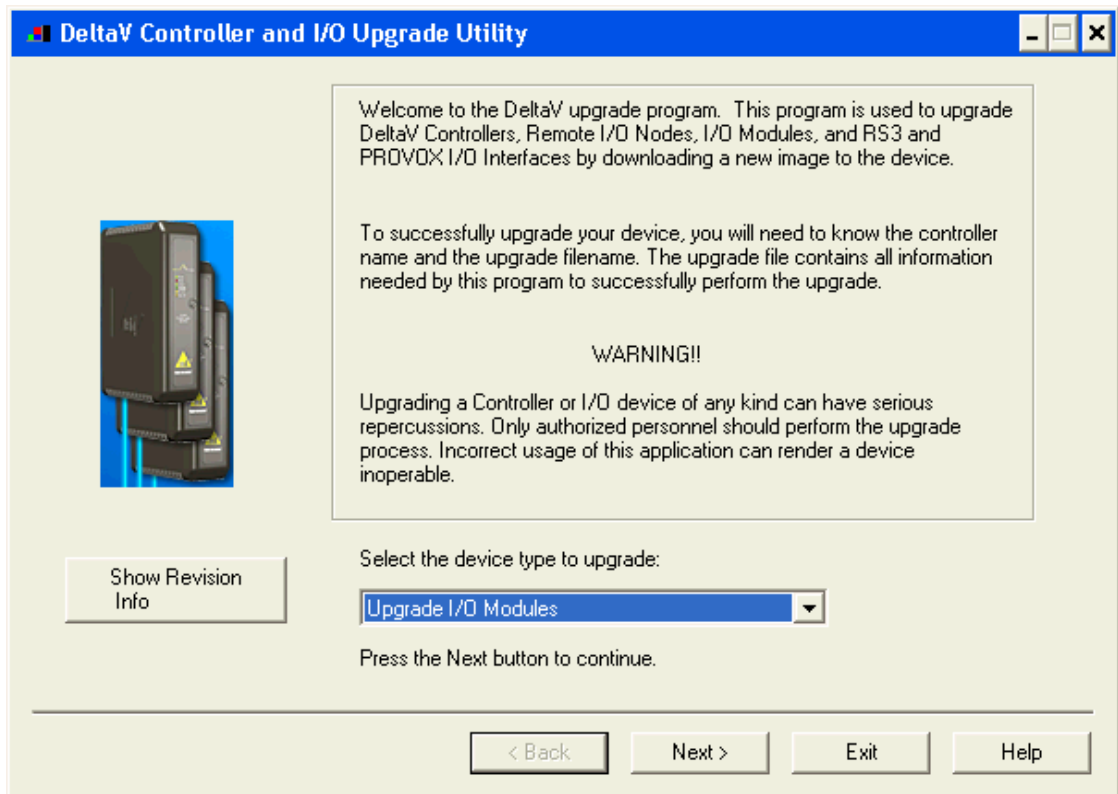



2. Choose Upgrade I/O Modules from the drop down menu and click Next.

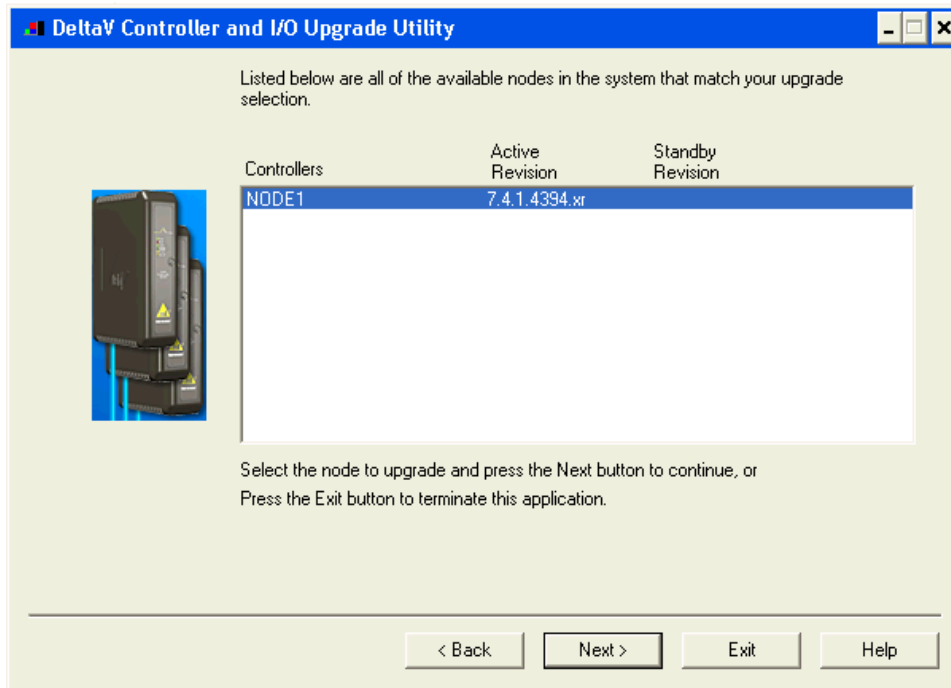

3. The above dialog will appear, listing all the available Controllers in your network. From this dialog, select the appropriate Controller and then Click Next.

4. The following dialog will appear, listing all the I/O modules in your selected Controller. The shown list of I/O modules is an example only. Your list will be different.

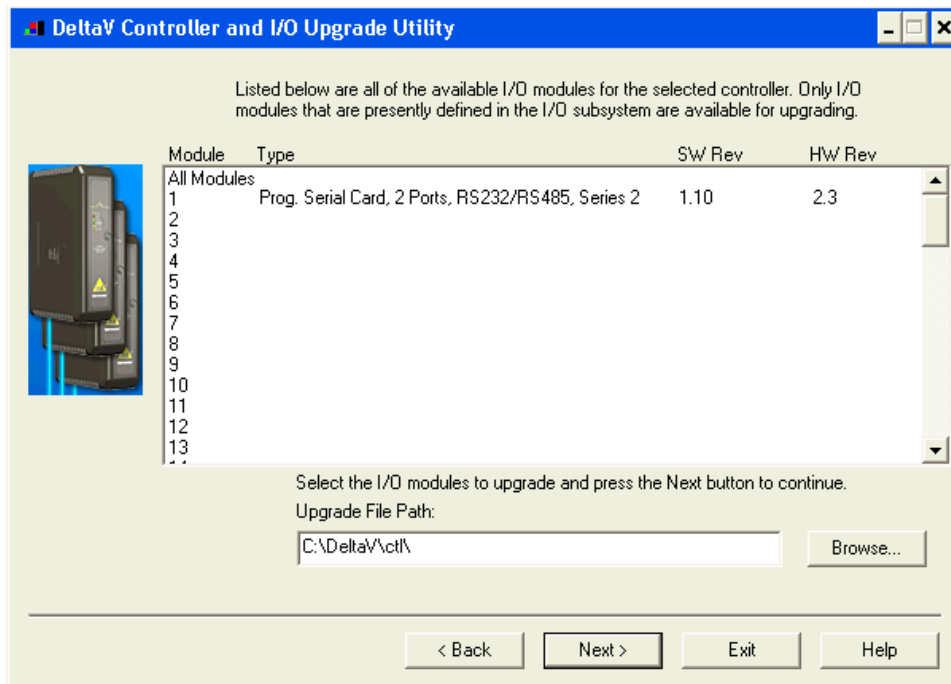



Note: The first time a standard Serial card is upgraded to the ControlNet Driver, the dialog will be as shown below. When upgrading an existing Programmable Serial Card, skip Steps 4, 5 and 6, and go to Step 7.

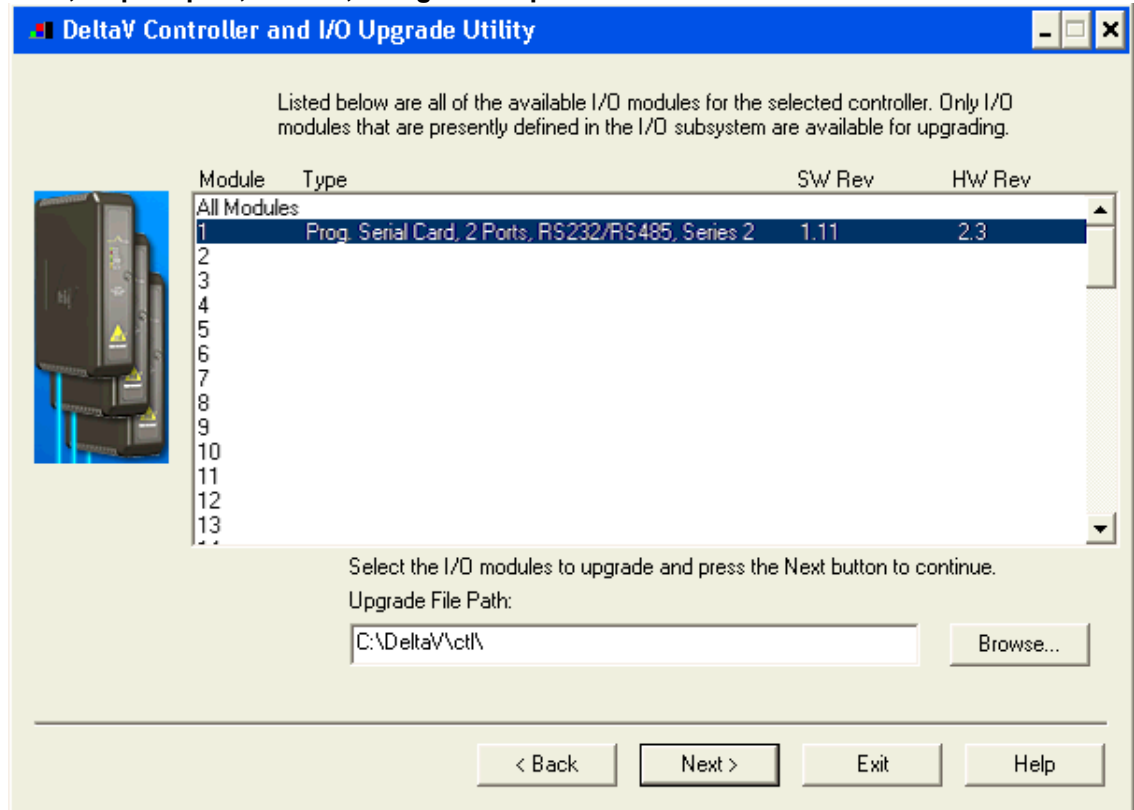



5. Click the Browse button and select the DeltaV path as shown below, and then click Ok. Note that the disk drive could be C or D.

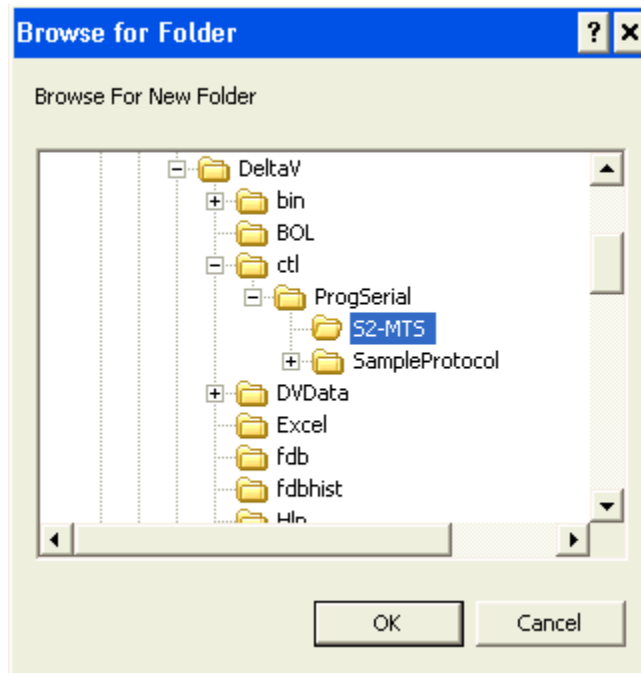

6. Select the I/O module again as shown below and then click Next. Go to Step 9.

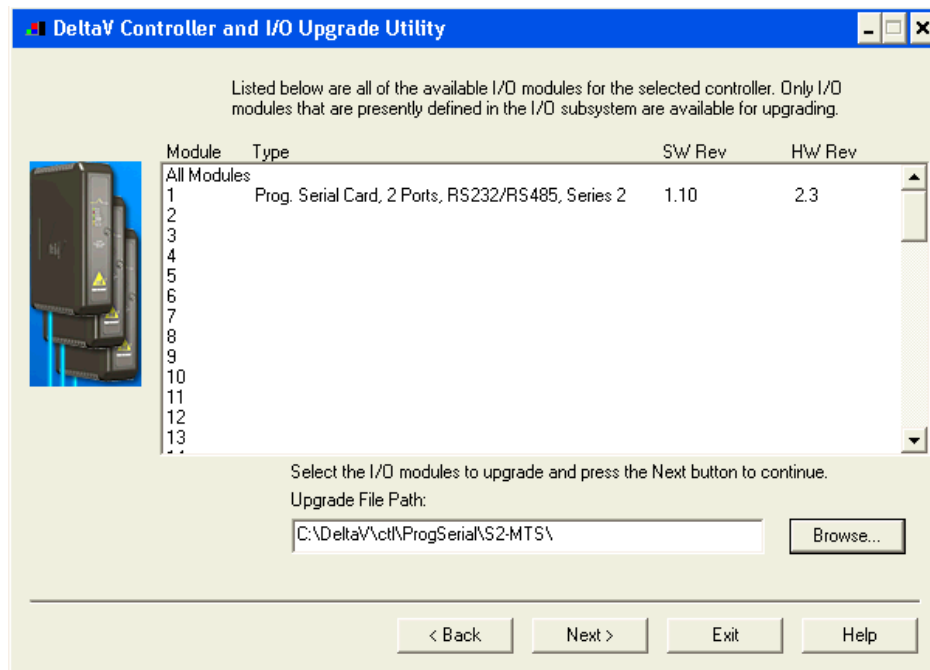



7. If you are upgrading an existing Programmable Serial Card, the dialog will be as shown below. From this dialog, select the Programmable Serial Card I/O Module in the list.

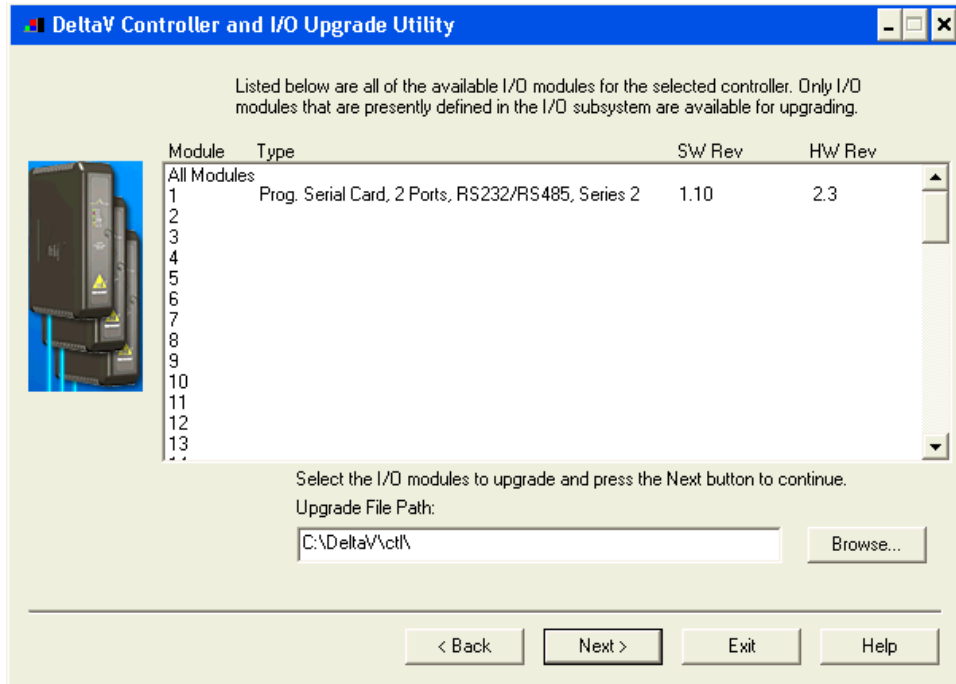

For example, we will select I/O Module 1. This will give you a dialog, from which you will select the file path to where the driver software is located. This path will be:

\\DeltaV\ctl\ProgSerial\S2-MTS

Once you are in the specified directory, you will need to select the following file:

S2-MTS.S2F

This is shown in the following dialog.

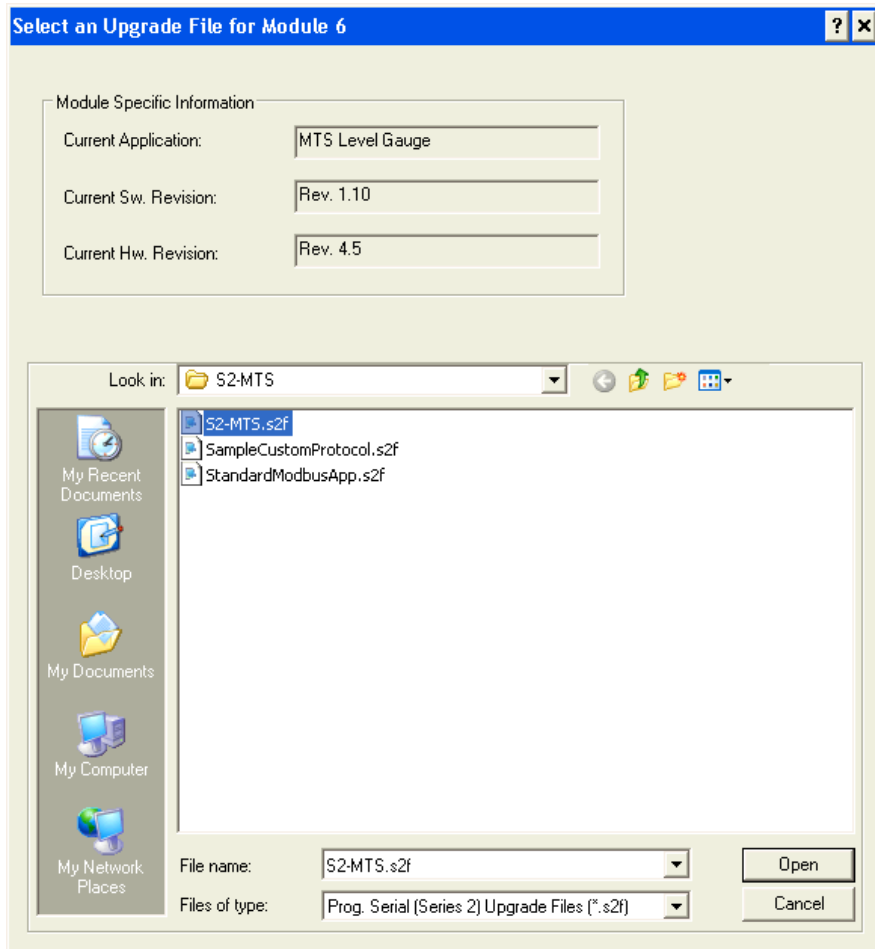



8. After selecting the .S2F file, Click on Open. This dialog will close and you will be back to the following:

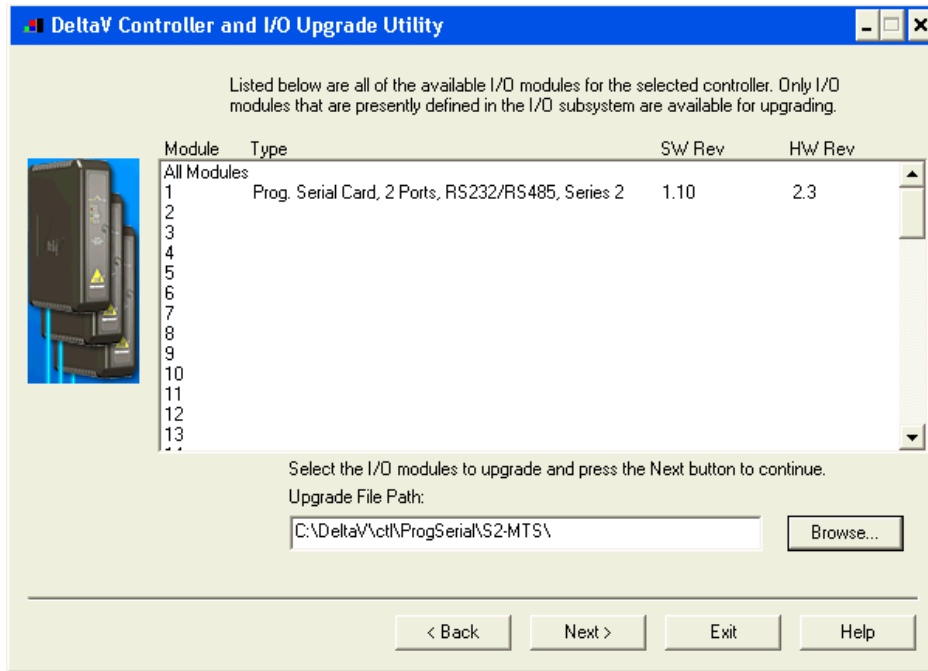

9. In this dialog, Click Next again. You will get the following dialog, confirming the Controller and I/O Module to program.

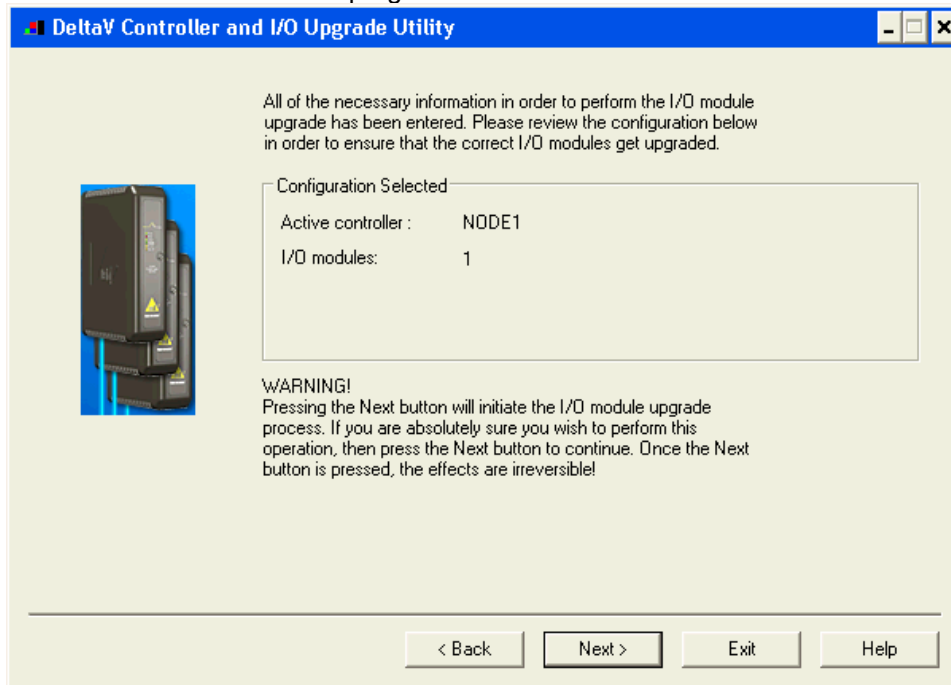



10. Click Next and the I/O Module upgrade process will begin. After completion, you will receive the following dialog, indicating success.

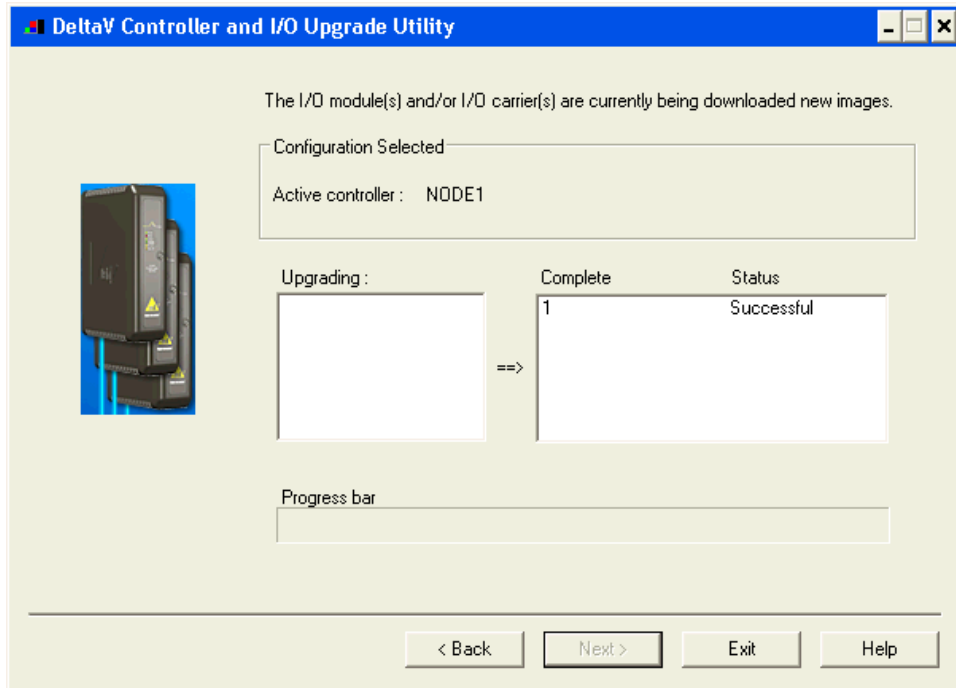

11. This completes the I/O Module upgrade process.



4 CONFIGURATION INFORMATION

DeltaV comprises an I/O sub-system, in which the PSIC is one type of card. The purpose of the PSIC is to serially integrate third-party devices, allowing data to be read into and written out from DeltaV. The PSIC has 2 communication ports that can be configured as RS-232, RS-485 (Half Duplex), or RS-422 (Full Duplex). Various communications parameters, such as baud rate, are configurable.

Under each communication port, a user can configure devices; their addresses do not matter in this driver. Under devices, one or more datasets can be assigned. There are a maximum of 16 datasets available for each port. The datasets are of type Floating Point, with 50 registers. Each dataset will support up to 5 devices. The addresses of each device are stored in the Special Data area of the dataset. If a Special Data value of the dataset is set to 0 that device slot is considered empty and it will not be scanned. Each device will use 10 of the 50 registers, the first 8 registers for data, and the last as error flags.

The communication port must be configured as Master. More than one MTS Level Gauge can be configured under each communication port. This will require the electrical connection to be RS-485 (half duplex), RS-422 (full duplex), or RS-232 (full duplex) using an appropriate signal converter. Since each dataset supports up to 5 devices, a maximum of 80 devices can be configured under each communication port.

The figure below shows an example MTS Level Gauge setup:

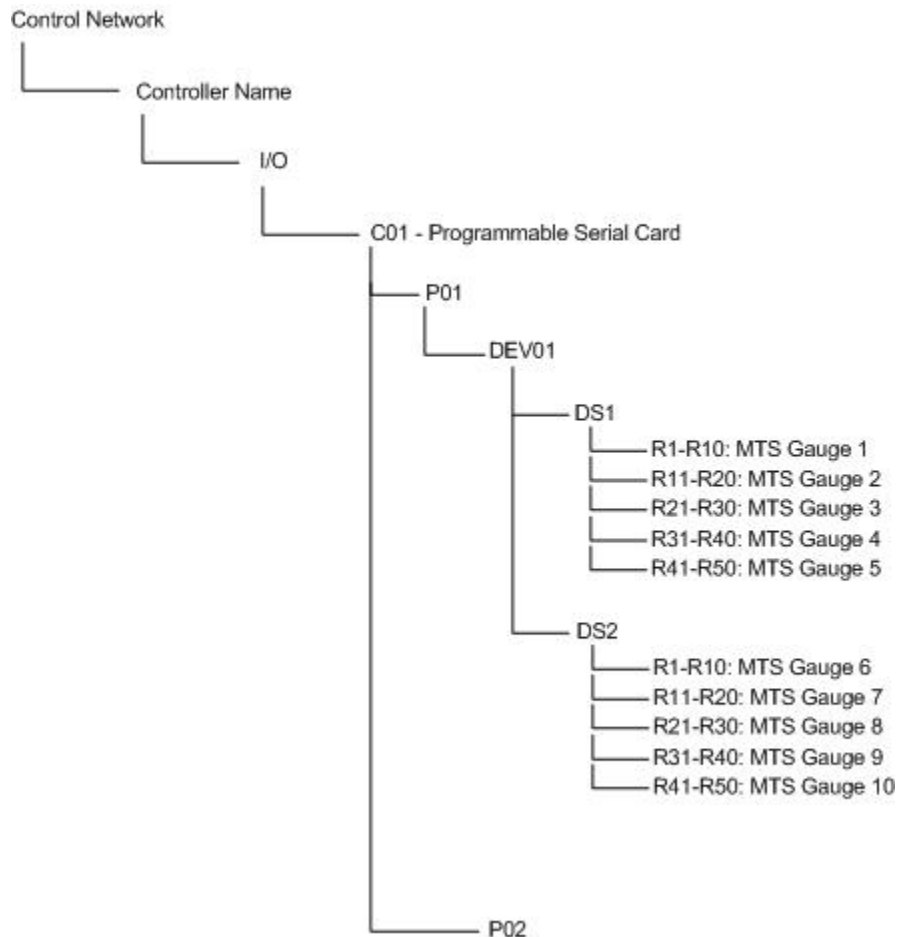



4.1 Port Configuration

The port should be configured as master. Retry Count, and Transmit Delay can be left as default or changed at users discretion. The Message Timeout should be set high enough so that the temperature readings can be performed, this can take upwards of 16 seconds depending on Level Gauge type and number of RTD's. The Port Type should be defined as RS485 Half-Duplex. The MTS Level Gauge does not support full Duplex RS-485. RS-232 is supported via a RS485 to RS232 media converter. The Baud Rate and Stop Bits should match the settings in the MTS Level Gauge devices. Parity should be set to "None" and Data Bits to "8".

4.2 Device Configuration

One device should be configured for all of the datasets. The device address is not used. Up to 16 datasets may be configured per port, each of which can communicate with up to 5 Level Gauges, allowing for a total of 160 Level gauges per PSIC.

4.3 Dataset Configuration

4.3.1 Data Direction:

One dataset will be defined. The dataset will be an Input Dataset.

4.3.2 Output Mode and Readback:

Output mode will not be used in this driver and can be left as default. Readback mode will also not be used and should not be checked.

4.3.3 DeltaV Data Type:

See below.

4.3.4 Device Data Type and Number of Values

Table 3: Dataset Configuration

DATASET	DeltaV DATA TYPE	DEVICE DATA TYPE	DATA START ADDRESS	NUMBER OF VALUES
1	Float	0	0	50

4.3.5 Special Data

The Special Data values (1-5) will be used to configure the addresses of the MTS Level Gauges. Valid addresses are 192-253. If a 0 is present, that will designate no device.



4.3.6 Register Mappings

Each MTS Level Gauge uses 10 registers. The usage is shown below in Table 5. Register 10, the General Error Flags is a bitmap of which values are in an error state. Register 1 is bit 1, register 2 is bit 2, and so on. For example, if the driver got an error code for Temperature 5 from the MTS Level Gauge, the value in register 10 would be 64. Only 2 commands are used: 0x12 to retrieve the levels and 0x21 to retrieve the temperatures as described below.

Table 4: Commands

Command	Description
0x12	Send Level 1 (product), level 2 (interface) at 0.001 inch resolution.
0x21	Average and Individual RTD temperature at 0.02 degree F resolution.

To prevent self-heating of the RTD's, the temperature retrieval will only performed every minute. Unused or temperatures in error will be set to 0 in the dataset registers.

Table 5: Dataset Register Mapping for Gauge Data

Description	Device	Register
Level 1 (Product) 0.001 accuracy	1 st Device	1
Level 2 (Interface) 0.001 accuracy	1 st Device	2
Temperature 1	1 st Device	3
Temperature 2	1 st Device	4
Temperature 3	1 st Device	5
Temperature 4	1 st Device	6
Temperature 5	1 st Device	7
Average Temperature of all RTD 0.02 accuracy	1 st Device	8
Unused	1 st Device	9
General Error Flags	1 st Device	10
Level 1 (Product) 0.001 accuracy	2 nd Device	11
Level 2 (Interface) 0.001 accuracy	2 nd Device	12
Temperature 1	2 nd Device	13
Temperature 2	2 nd Device	14
Temperature 3	2 nd Device	15
Temperature 4	2 nd Device	16
Temperature 5	2 nd Device	17
Average Temperature of all RTD 0.02 accuracy	2 nd Device	18
Unused	2 nd Device	19
General Error Flags	2 nd Device	20
...
Level 1 (Product) 0.001 accuracy	5 th Device	41
Level 2 (Interface) 0.001 accuracy	5 th Device	42
Temperature 1	5 th Device	43
Temperature 2	5 th Device	44
Temperature 3	5 th Device	45
Temperature 4	5 th Device	46
Temperature 5	5 th Device	47
Average Temperature of all RTD 0.02 accuracy	5 th Device	48
Unused	5 th Device	49
General Error Flags	5 th Device	50



4.3.7 General Error Flags

There will be a single general error flags register per gauge. The error register will be used as a bit-mask. The driver will initialize this register to 0 on startup, indicating all values to be good. If there is an error code received from the gauge, the driver will set the corresponding bit to a 1. The bit will be cleared when the error clears. The (1-based) bits are assigned as follows:

Table 6: General Error Flags

Description	Bit number
Level 1 (Product)	1
Level 2 (Interface)	2
Temperature 1	3
Temperature 2	4
Temperature 3	5
Temperature 4	6
Temperature 5	7
Average Temperature	8



5.0 Operational Check

5.1 Scope

The following sections provide some assistance to ensure the interface is working properly.

5.2 Verify Hardware and Software Version Number

The user can verify that the MTS Level Gauge driver has been installed using the DeltaV Diagnostics tool. The Diagnostics tool will show the Hardware Revision No. (HwRev) and the Software Revision No. (SwRev).

To begin the DeltaV Diagnostic tool select Start-> DeltaV-> Operator-> Diagnostics. In the Diagnostics tool expand the Controller, I/O and then double click on the Programmable Serial Interface Card that has the driver installed.

The following information will be displayed:

:	:	:
HwRev	Hardware Revision	1.10 (or later)
SwRev	Software Revision	2.3 (or later)

5.3 Verify Configuration

- Verify port configuration: The serial port must be enabled. User needs to make sure communication settings such as baud rate, parity, and number of data bits match the MTS Level Gauge settings.
- Verify device configuration: User must check for the proper device address is entered. The MTS Level Gauge local address should match one of the Special Data values.
- Verify Dataset configuration: The first Dataset should be defined as Input, Floating Point, with 50 values



5.4 Verify I/O Communication With Control Studio

- User can create I/O modules in the control studio to verify correct values are read and written between the foreign device into the PSIC. For input data, the values should be changed in the foreign device and verified that the new data are correctly reported. For output data, change the values in the controller and then verify that the values are transferred to the foreign device.
- To assign a Dataset and a register in the Dataset to an I/O module, follow these steps:
 1. Double click the IO_IN/IO_OUT parameter for the module. This brings up the IO_IN/IO_OUT Property window.
 2. Click on the Browse button. This brings up the Browse window.
 3. Click on the Object_Type drop down list, select All. This displays all the Dataset tags.
 4. Double click on the desired Dataset tag. This assigns the tag to the module and closes the Browse window.
 5. Choose the desired register in the Parameter drop down list.
 6. Click the OK button.
- For output modules, user also needs to change the MODE parameter to Manual for Normal Mode and Target.

5.5 Using Diagnostics

- Verify PSIC communication: Select the PSIC on Diagnostics and press the right mouse button. Select Display Real -Time Statistics from the drop down menu. If the Programmable Serial Interface Card is functioning then the user will see the Valid Responses counter and the Async and/or Sync Transactions counters incrementing. There will not be any error counting up.
- Verify port statistics: Select the Port on the Programmable Serial Interface Card and press the right mouse button. Then select Display Port Statistics form the drop down menu. Verify that the port communications statistics are being displayed properly and are counting as expected for the protocol's functionality.
- Verify dataset values: Select a dataset and press the right mouse button. Select View Dataset Registers from the Drop down window. Verify that the dataset values are displayed as expected.

5.6 LED Indication

The Yellow LED for the port should be on solid when all communications on that port are valid. The Yellow LED should be blinking if there is some valid communications and some communications with errors on that port. The Yellow LED should be OFF if there are no valid communications on that port.



6 DeltaV–Field Device Electrical Interface

The electrical interface between DeltaV and field devices conforms to the RS-232 and RS-422/485 standards.

Each PSIC has 2 ports. The MTS Level Gauge operates in RS485 Half-Duplex mode only. If RS232 is desired, the appropriate converter must be used.

6.1 Pin Assignments for DeltaV PSIC

RS-422/485 Half Duplex Standard

Table 7: DeltaV Wiring Configuration

Terminal Number	Signal Description
1	Port 1 – Isolated Ground (GND)
2	Port 1 - Data +
3	Unused
4	Port 1 - Data -
5	Unused
6	Unused
7	Unused
8	Unused
9	Port 2 – Isolated Ground (GND)
10	Port 2 – Data +
11	Unused
12	Port 2 - Data -
13	Unused
14	Unused
15	Unused
16	Unused



6.2 Wiring Connections

The figure below shows the connections between the MTS Level Gauge RS485 port and Port 1 on the Serial Card Termination Block.

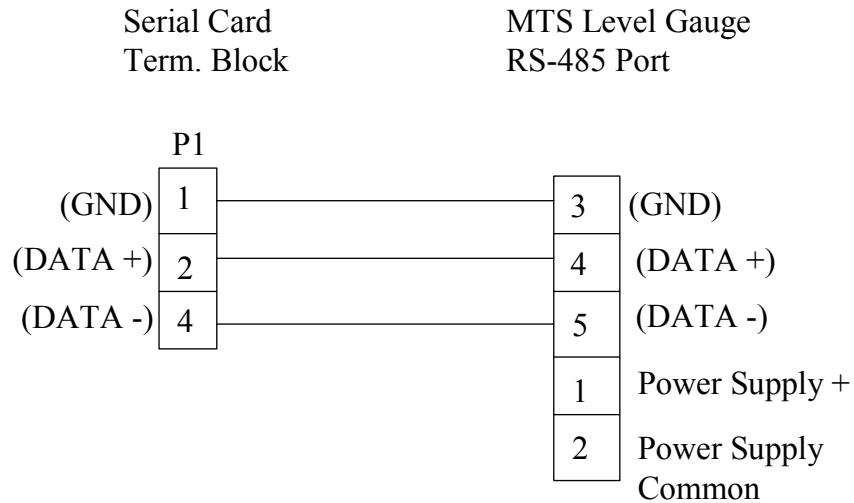



M Y N A H™

POWERFUL SOLUTIONS FOR DIGITAL PLANTS

7 Technical Support

For technical support or to report a defect, please give Mynah Technologies a call at (636) 681-1555. If a defect is discovered, please document it in as much detail as possible and then fax your report to us at (636) 681-1660.

For Product functionality questions, ask for the people in the following order:

1. David Story
2. Adisa Shaljani

For Commercial issues, ask for people in the following order:

1. Martin Berutti
2. Todd Anstine

You can also send us your questions via e-mail. Our address is:

support@mynah.com

Thank you for using DeltaV.