



M Y N A HSM

**Turret and Tundish Weigh Scale
Programmable Serial Interface Card
Series 2**

USER MANUAL

Rev. P1.10

September 19, 2008

DeltaV is a trademark of Emerson Process Management, Inc © Emerson Process Management, Inc. 1998, 1999. All rights reserved.

Printed in the U.S.A.

While this information is presented in good faith and believed to be accurate, MYNAH Technologies does not guarantee satisfactory results from reliance upon such information. *Nothing contained herein is to be construed as a warranty or guarantee, express or implied, regarding the performance, merchantability, fitness or any other matter with respect to the products, nor as a recommendation to use any product or process in conflict with any patent.* MYNAH Technologies reserves the right, without notice, to alter or improve the designs or specifications of the products described herein.



1 INTRODUCTION

1.1 Scope

This document is the User Manual for the Turret and Tundish Weigh Scale communications driver firmware for the Emerson Process Management (EPM) DeltaV Control System. The driver runs in the DeltaV Series 2 Programmable Serial Interface Card (PSIC). The reader should be familiar with EPM's DeltaV PSIC and connected weigh scale devices.

1.2 Document Format

This document is organized as follows:

Introduction	Describes the scope and purpose of this document.
Theory of Operation	Provides a general functional overview of the Driver.
Downloading Firmware	Describes downloading procedures for the driver firmware on to the DeltaV PSIC.
Configuration Information	Describes procedures and guidelines for configuring the DeltaV PSIC.
Operational Check	Provides tips and assistance to ensure PSIC is properly setup and configured.
DeltaV–Field Device Electrical Interface	Describes the electrical interface between DeltaV and the weigh scale devices. Also describes the cable pin assignments for RS-232.
Technical Support	Describes who to call if you need assistance.



1.3 System Specifications

The following table lists the minimum system requirements for the driver:

Protocol Compatibility and Reference documents	The weigh scale message format/protocol used is documented in Section 4 below.
Software Requirements	DeltaV System Software (Release 6.3.2 or later) installed on a hardware-appropriate Windows workstation configured as a ProfessionalPlus for DeltaV Serial Interface Port License (VE4102)
Minimum DeltaV Hardware Requirements	FRSI DeltaV Serial Interface Series 2, Hardware PN: 12P2506X022 FRSI DeltaV M3, M5, MD or Series 2 MD Controller, Power Supply and 2 wide controller carrier FRSI 8 wide I/O card carrier



2 THEORY OF OPERATION

The Programmable Serial Interface Card (PSIC) has 2 ports which can be configured for RS-232, RS-422/RS-485 Half Duplex or RS-422/RS-485 Full Duplex communications with external devices.

For communications with Turret and Tundish Weigh Scales, the PSIC connects to the RS-232 port of the device. Each PSIC port may be connected to a single weigh scale as illustrated below. The default port settings are 9600 baud, 8 data bits, no parity.

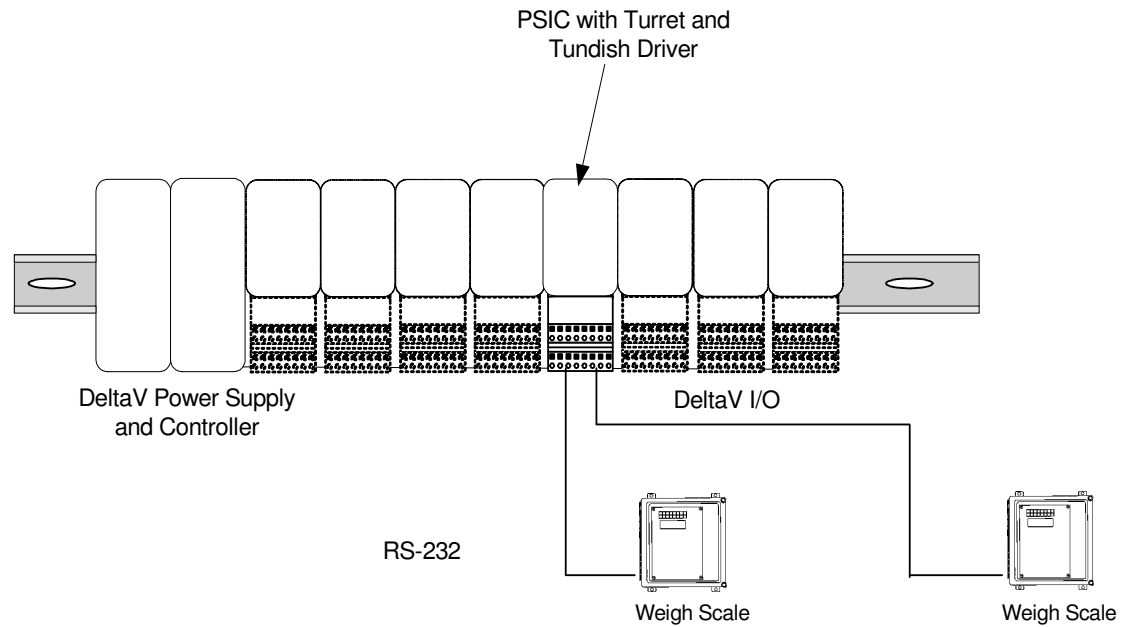

Turret and Tundish Weigh Scale
DeltaV Setup Information

The driver runs in Slave mode only. Each weigh scale uses two datasets. Dataset 1 contains the weight data. Dataset 2 contains the weight units, weight type and any reported alarms.

Being the Slave device, the serial card simply waits for weight messages from the scale. Each received message is parsed according to the expected fixed format, and the results are stored in dataset registers. The expected format is documented in Section 4.



3 Downloading the firmware

The driver software distribution comprises 15 files, distributed on a CD. These files must be copied to the DeltaV directory on your ProPlus Workstation. The path is:

\DeltaV\ctl\ProgSerial\S2-TURRET-TUNDISH

Note that you will have to create the \S2-TURRET-TUNDISH subdirectory. The following files will be copied:

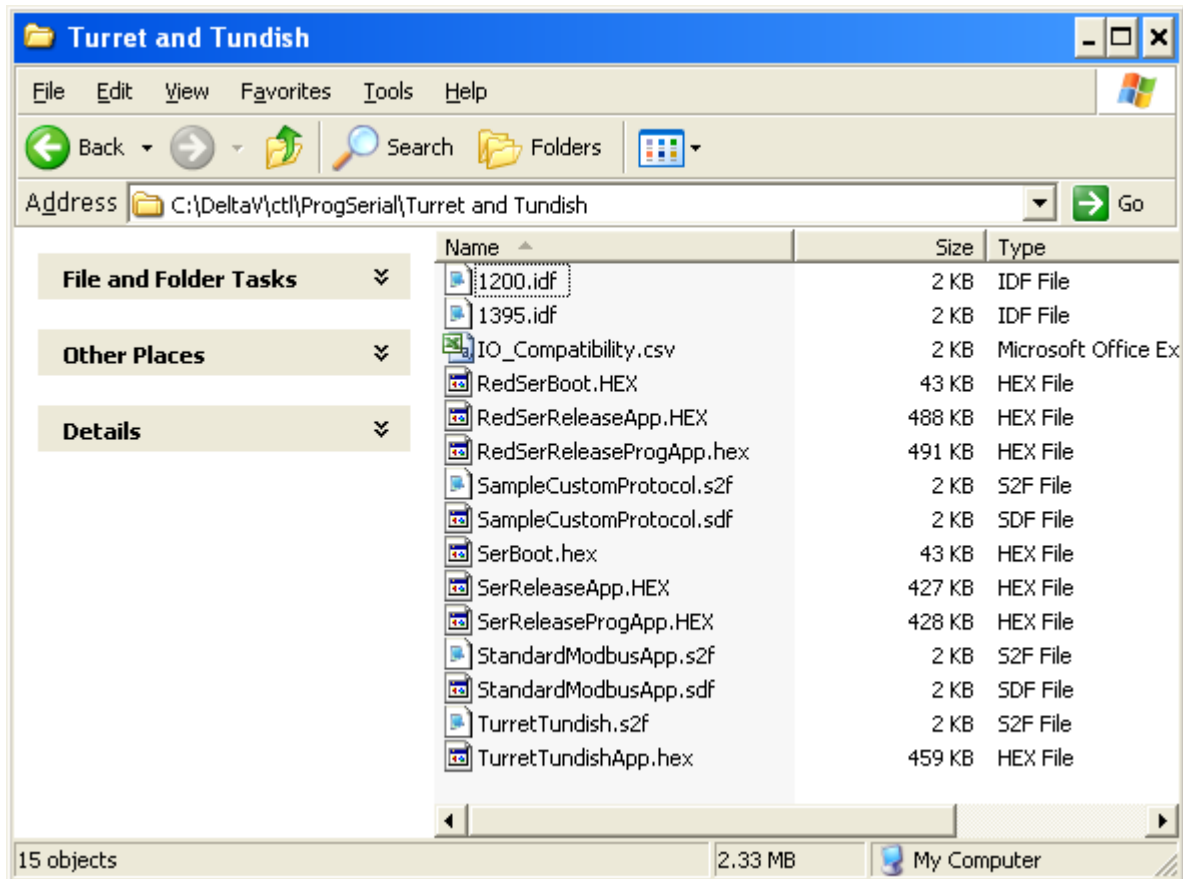



After copy completion, you are ready to program (or upgrade) the Programmable Serial Card with the supplied custom driver software. The steps are as follows:

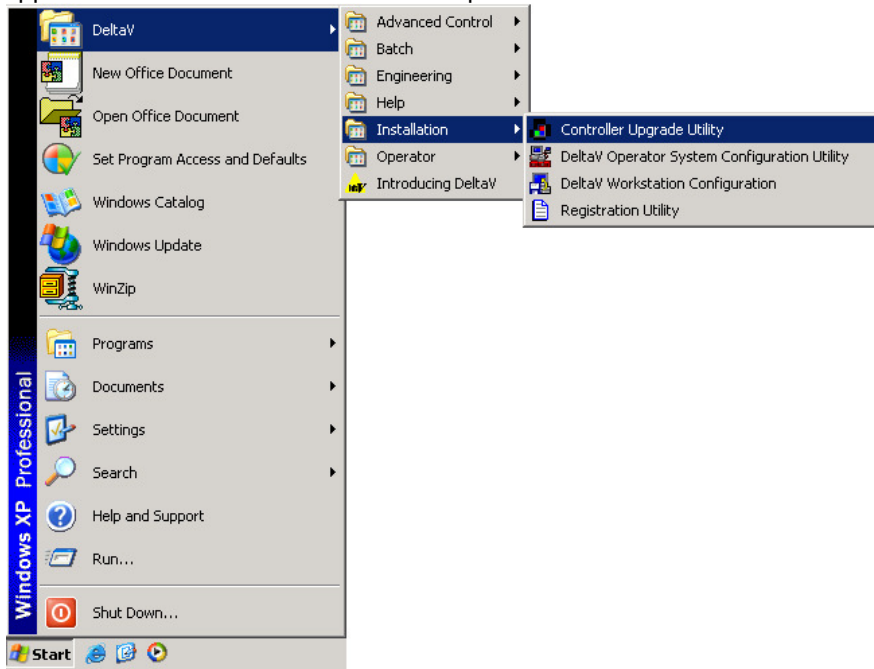

1. Click on the Start button and select DeltaV-> Installation-> Controller Upgrade Utility as shown below, and the following dialog will appear:

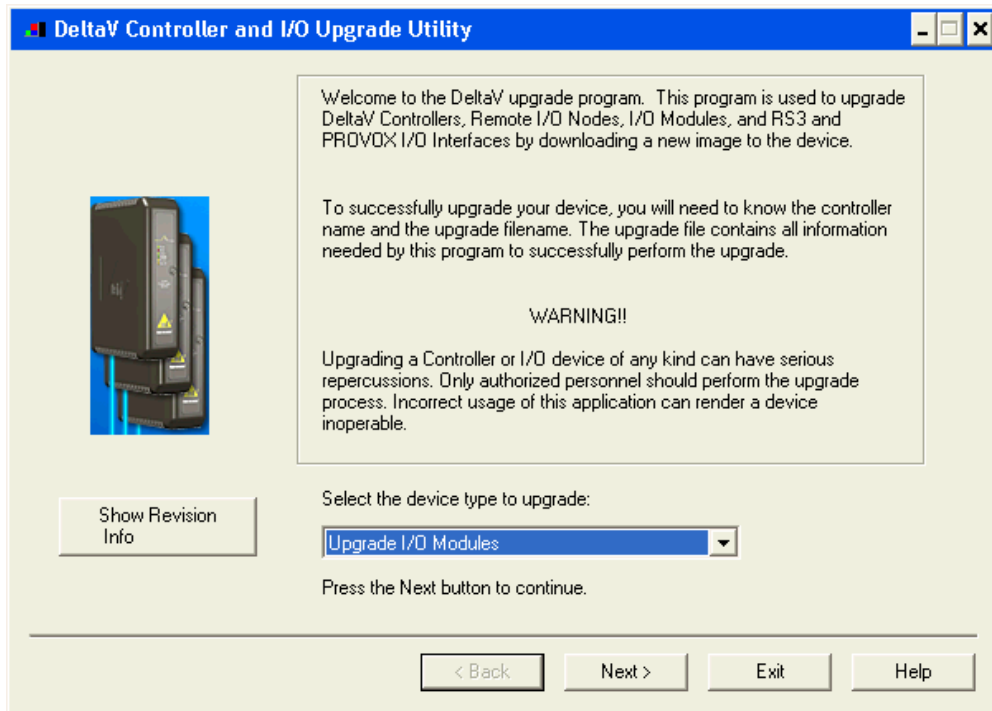

2. Choose Upgrade I/O Modules from the drop down menu and click Next.

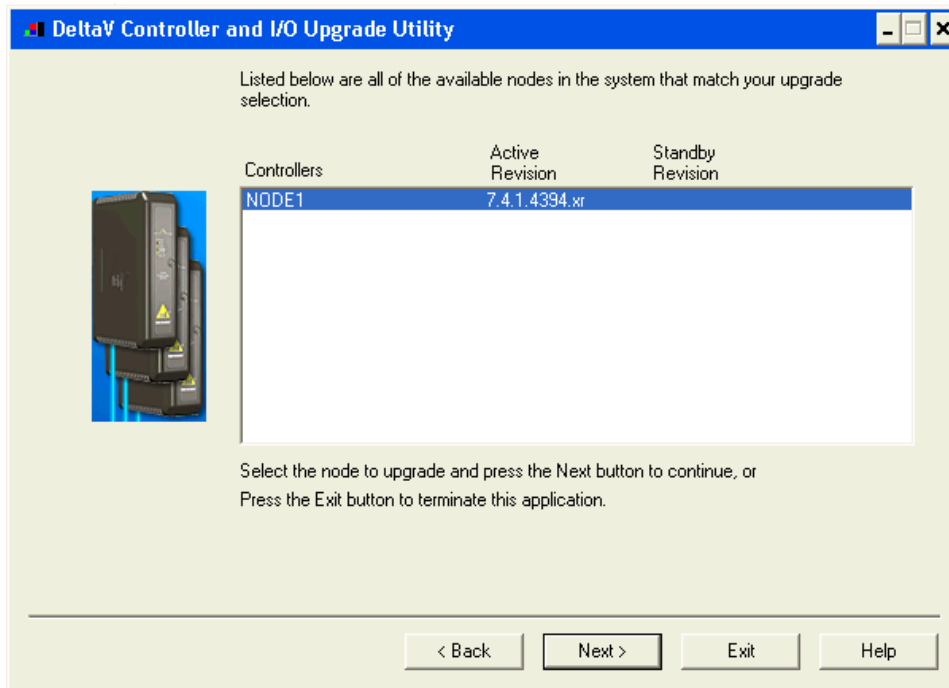

3. The above dialog will appear, listing all the available Controllers in your network. From this dialog, select the appropriate Controller and then Click Next.

4. The following dialog will appear, listing all the I/O modules in your selected Controller. The shown list of I/O modules is an example only. Your list will be different.

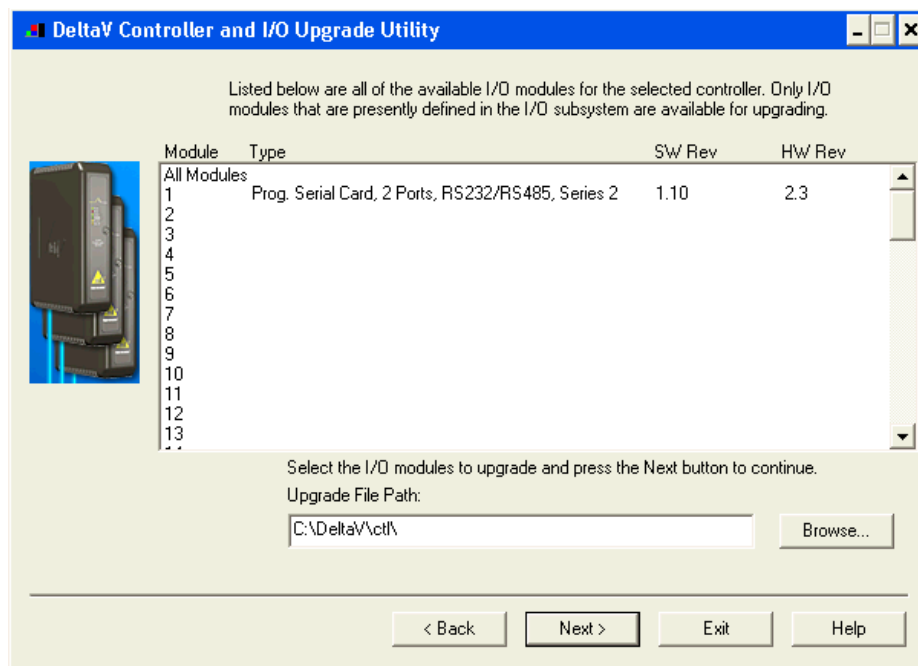



Note: The first time a standard Serial card is upgraded to the ControlNet Driver, the dialog will be as shown below. When upgrading an existing Programmable Serial Card, skip Steps 4, 5 and 6, and go to Step 7.

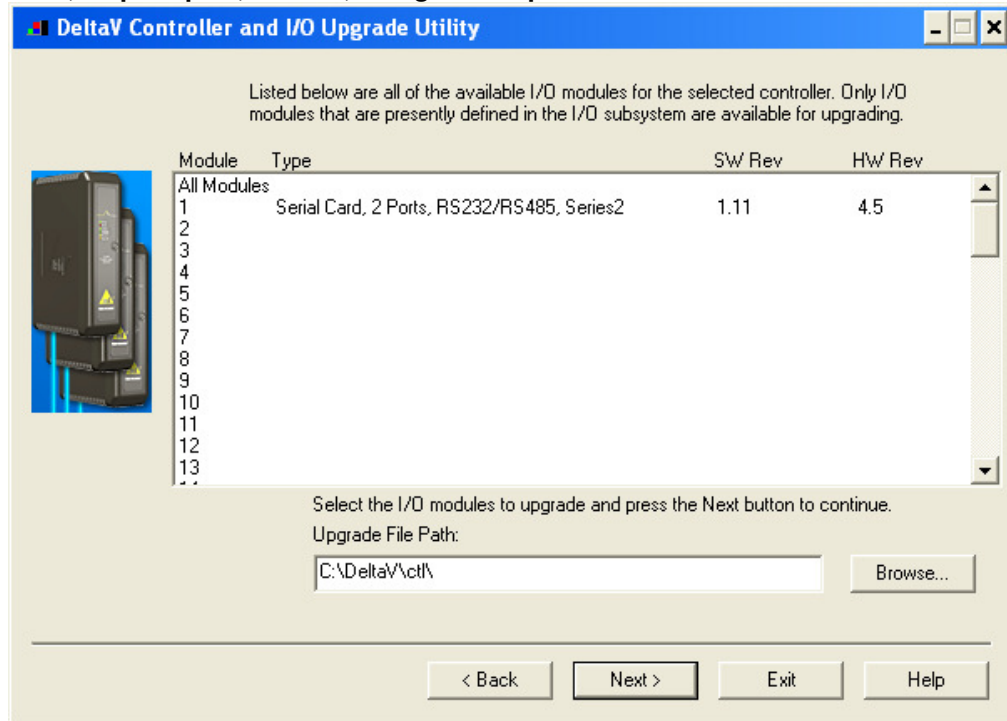

5. Click the Browse button and select the DeltaV path as shown below, and then click Ok. Note that the disk drive could be C or D.

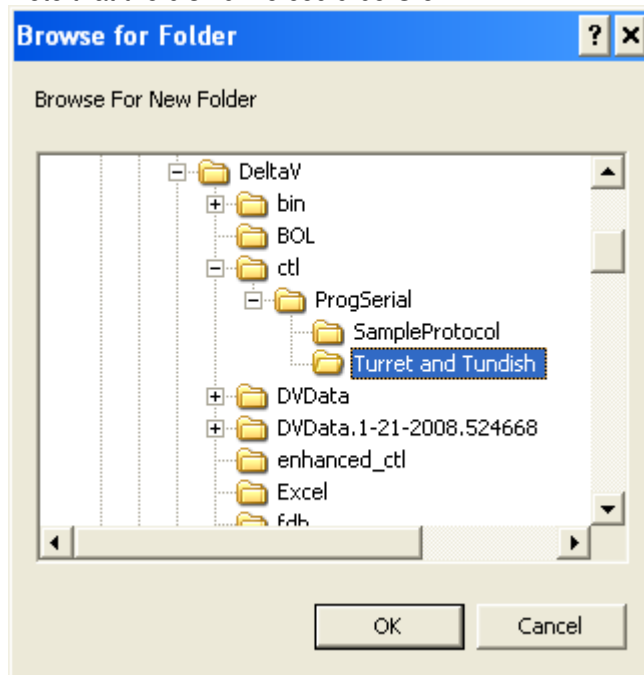



6. Select the I/O module again as shown below and then click Next. Go to Step 9.

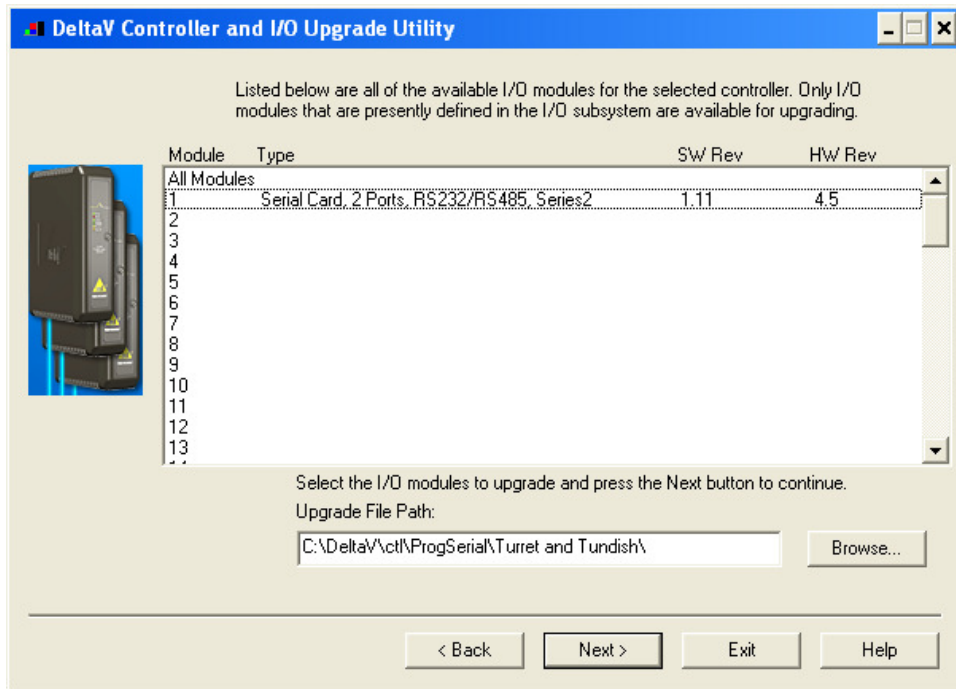

7. If you are upgrading an existing Programmable Serial Card, the dialog will be as shown below. From this dialog, select the Programmable Serial Card I/O Module in the list.

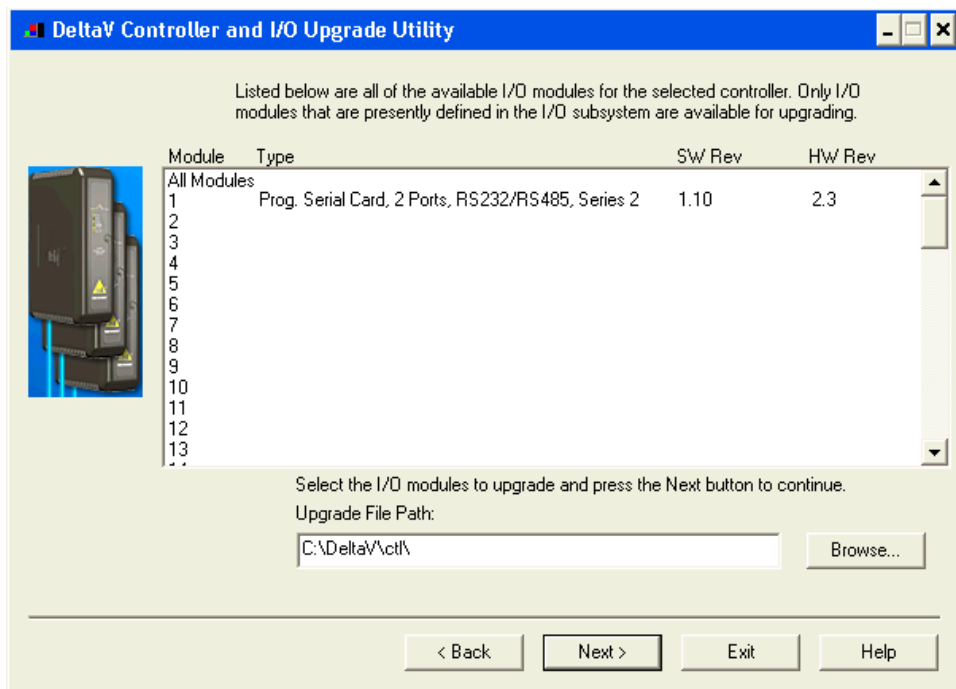



For example, we will select I/O Module 1. This will give you a dialog, from which you will select the file path to where the driver software is located. This path will be:

\\DeltaVct\ProgSerial\S2-TURRET-TUNDISH

Once you are in the specified directory, you will need to select the following file:

S2-TURRET-TUNDISH.S2F

This is shown in the following dialog.

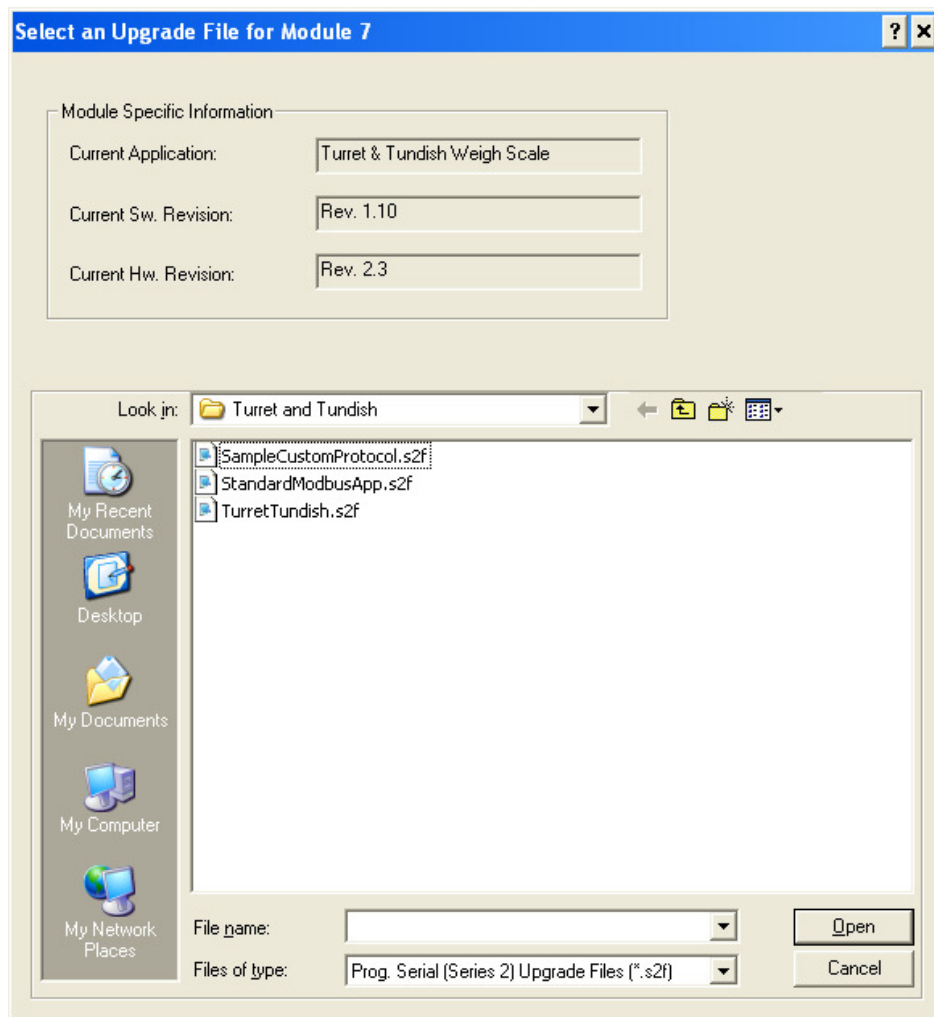



8. After selecting the .S2F file, Click on Open. This dialog will close and you will be back to the following:

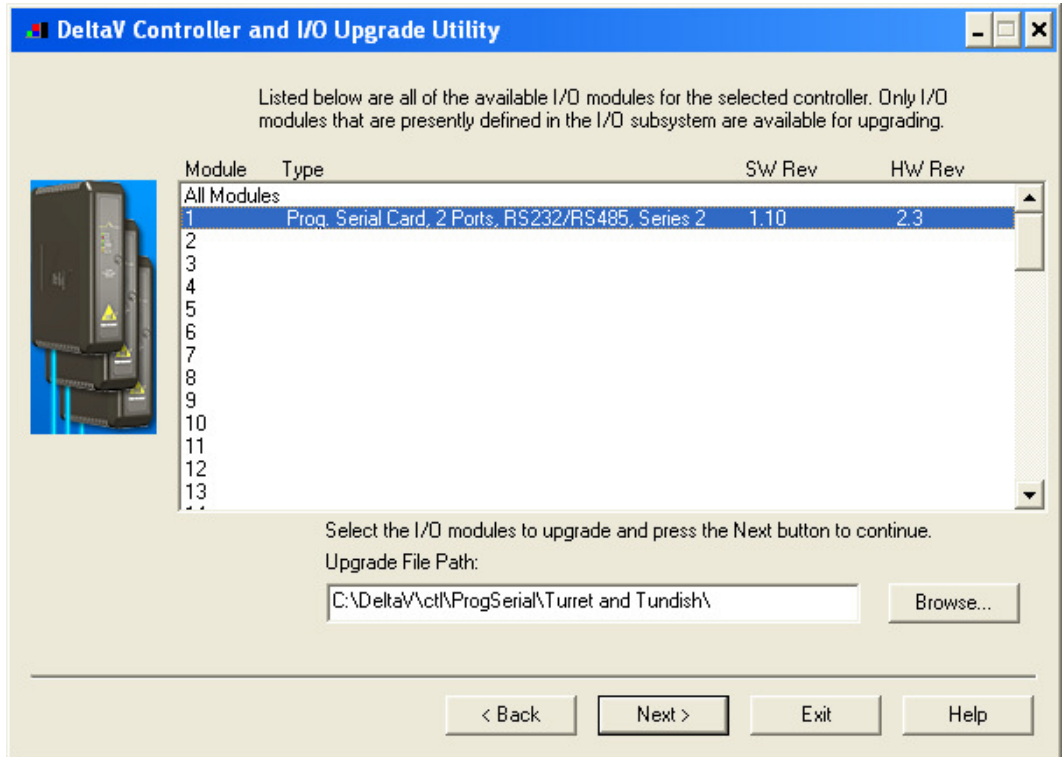

9. In this dialog, Click Next again. You will get the following dialog, confirming the Controller and I/O Module to program.

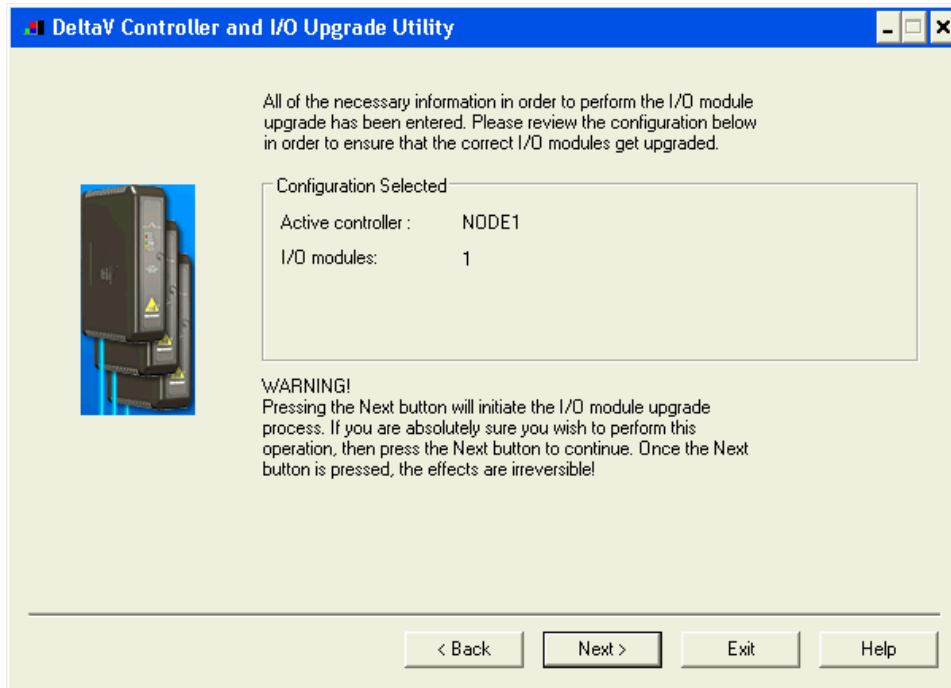

10. Click Next and the I/O Module upgrade process will begin. After completion, you will receive the following dialog, indicating success.

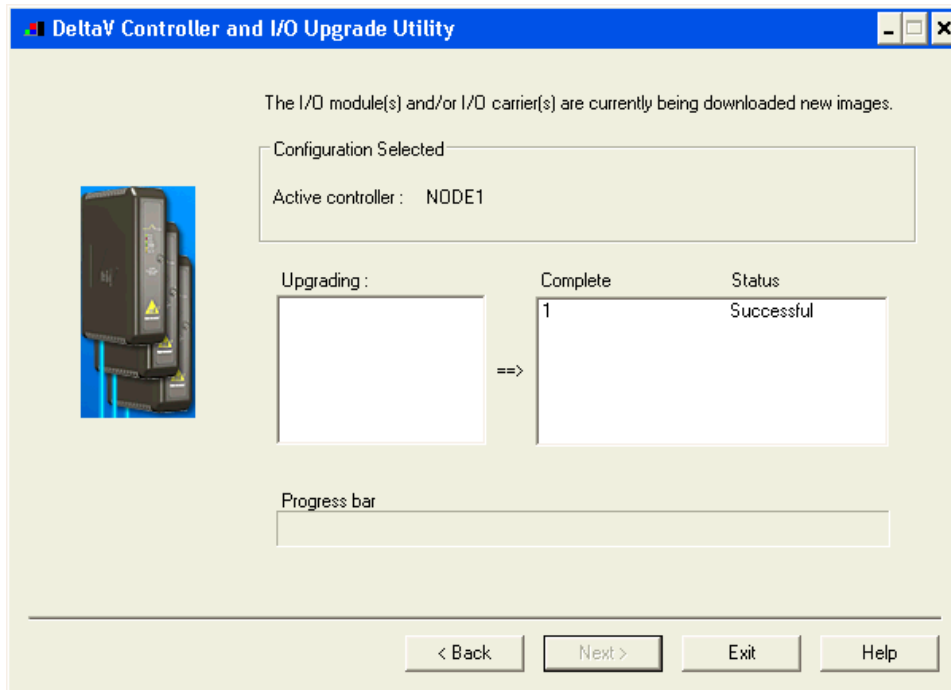

11. This completes the I/O Module upgrade process.



4 **CONFIGURATION INFORMATION**

Under each port, there exist 16 datasets. Data from attached weigh scales will be stored in two datasets only. There can only be one scale attached per port. Under the port a device is created for the attached scale. The device address is not needed and may be disregarded in this driver.

The data sent from the weigh scale comprising System A or System B as one message is in the following format:

STX	Start character, 0x02
A or B	Upper case A for System A or B for System B
X	Space for positive data, or – sign for negative data
WWWWWWW	7 digits for total weight
UU	2 characters for units: LB, Kg, TN, or MT
N	Mode: N =Net or G=Gross
,	Comma delimiter
1A or 1B	Individual load cell identifier
X	Space for positive data, or – sign for negative data
WWWWWWW	7 digits for cell weight
,	Comma delimiter
2A or 2B	Individual load cell identifier
X	Space for positive data, or – sign for negative data
WWWWWWW	7 digits for cell weight
,	Comma delimiter
3A or 3B	Individual load cell identifier
X	Space for positive data, or – sign for negative data
WWWWWWW	7 digits for cell weight
,	Comma delimiter
4A or 4B	Individual load cell identifier
X	Space for positive data, or – sign for negative data
WWWWWWW	7 digits for cell weight
,	Comma delimiter
X	1 digit alarm data: 00=Ok, 01=Communication status, 02 Setpoint, 04=Power
,	Comma delimiter
CR	Message terminating carriage return



In some cases, the data sent from the weigh scale comprises both System A and System B as one message in the following format:

STX	Start characted, 0x02
A	Upper case A for System A
X	Space for positive data, or – sign for negative data
WWWWWWW	7 digits for total weight
UU	2 characters for units: LB, Kg, TN, or MT
N	Mode: N =Net or G=Gross
,	Comma delimiter
B	Upper case B for System B
X	Space for positive data, or – sign for negative data
WWWWWWW	7 digits for total weight
UU	2 characters for units: LB, Kg, TN, or MT
N	Mode: N =Net or G=Gross
,	Comma delimiter
1A	Individual load cell identifier
X	Space for positive data, or – sign for negative data
WWWWWW	6 digits for cell weight
,	Comma delimiter
2A	Individual load cell identifier
X	Space for positive data, or – sign for negative data
WWWWWW	6 digits for cell weight
,	Comma delimiter
3A	Individual load cell identifier
X	Space for positive data, or – sign for negative data
WWWWWW	6 digits for cell weight
,	Comma delimiter
4A	Individual load cell identifier
X	Space for positive data, or – sign for negative data
WWWWWW	6 digits for cell weight
,	Comma delimiter
1B	Individual load cell identifier
X	Space for positive data, or – sign for negative data
WWWWWW	6 digits for cell weight
,	Comma delimiter
2B	Individual load cell identifier
X	Space for positive data, or – sign for negative data
WWWWWW	6 digits for cell weight
,	Comma delimiter
3B	Individual load cell identifier
X	Space for positive data, or – sign for negative data
WWWWWW	6 digits for cell weight
,	Comma delimiter
4B	Individual load cell identifier
X	Space for positive data, or – sign for negative data
WWWWWW	6 digits for cell weight
,	Comma delimiter
AA	2 digit alarm data: 00=Ok, 01=Communication status, 02 Setpoint, 04=Power
CR	Message terminating carriage return



Two datasets, 1 and 2, will be configured to receive the weight data.

The figure below shows an example setup:

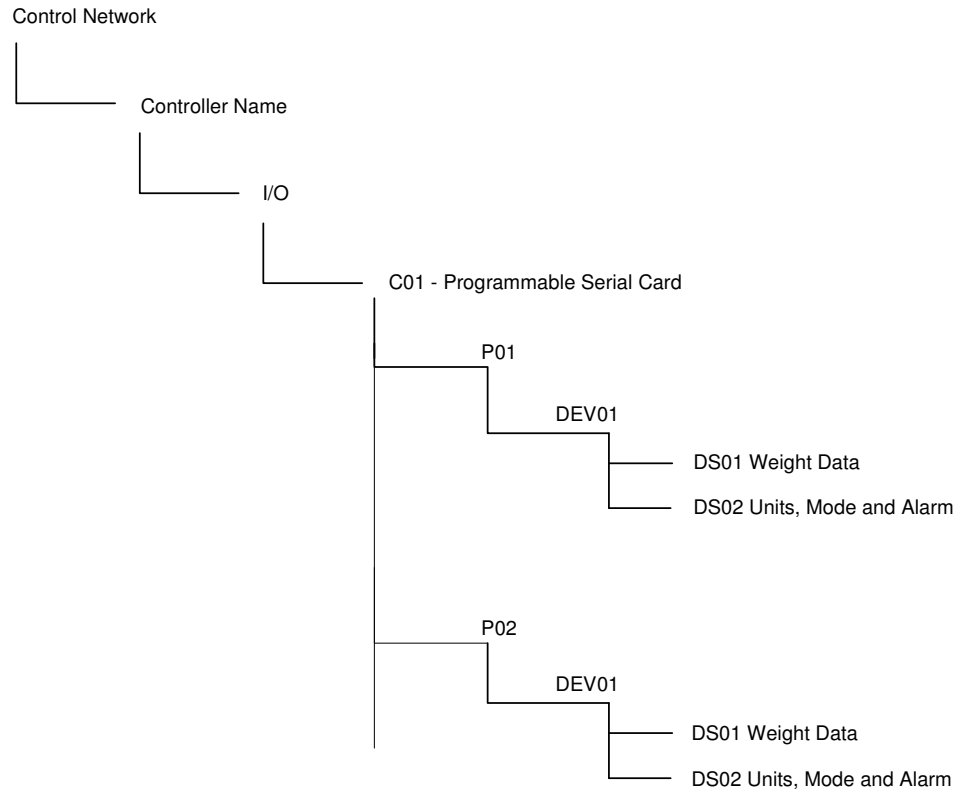

4.1 Port Configuration

The port should be configured as Slave. Transmit delay may be left as the default. The Port Type should be defined as RS-232. The Baud Rate, Parity, Data Bits and Stop Bits should match the settings of the weigh scale devices. These are 9600 baud, 8 data bits, no parity.

4.2 Device Configuration

One device should be configured for each weigh scale connected to a given port. The device address is not used in this driver. Only one device may be configured per port for a total of two per PSIC.

4.3 Dataset Configuration

4.3.1 Data Direction:



Configure 2 datasets. Since this is a slave driver, input or output does not need to be selected.

4.3.2 DeltaV Data Type:

See below.

4.3.3 Device Data Type and Number of Values

Table 1 – Dataset Configuration for each Weigh Scale

DATASET	DeltaV DATA TYPE	DEVICE DATA TYPE	DATA START ADDRESS	NUMBER OF VALUES
1	Floating Point	0	0	10
2	16-bit UINT	0	100	5

4.3.4 Special Data

Set Special Data1 of dataset 1 to the value 1 if the data message expected from the weigh scale is for System A or System B. If the data message is for the combined System A and System B, then Special Data 1 value must be set to 0.



4.3.5 Register Mappings

Table 2 – Dataset 1 Register Mapping

REGISTER	DESCRIPTION
1	System A Total Weight
2	System B Total Weight
3	Cell Weight – 1A
4	Cell Weight – 2A
5	Cell Weight – 3A
6	Cell Weight – 4A
7	Cell Weight – 1B
8	Cell Weight – 2B
9	Cell Weight – 3B
10	Cell Weight – 4B

Table 3 – Dataset 2 Register Mapping

REGISTER	DESCRIPTION
1	Units - System A Total Weight
2	Units - System B Total Weight
3	Mode - System A Total Weight
4	Mode - System B Total Weight
5	Scale Alarms

Units are stored as follows:

Table 4 – Units data

LB	1
Kg	2
TN	3
MT	4

Mode is stored as follows:

Table 5 – Mode data

Net	1
Gross	2



5 Operational Check

5.1 Scope

The following sections provide some assistance to ensure the interface is working properly.

5.2 Verify Hardware and Software Version Number

The user can verify that the weigh scale driver has been installed using the DeltaV Diagnostics tool. The Diagnostics tool will show the Hardware Revision No. (HwRev) and the Software Revision No. (SwRev).

To begin the DeltaV Diagnostic tool select Start-> DeltaV-> Operator-> Diagnostics. In the Diagnostics tool expand the Controller, I/O and then double click on the Programmable Serial Interface Card that has the driver installed.

The following information will be displayed:

:	:	:
SwRev	Software Revision	1.10 (or later)
HwRev	Hardware Revision	2.3 (or later)

5.3 Verify Configuration

- Verify port configuration: The serial port must be enabled. It must be set to Slave mode. User needs to make sure communication settings such as baud rate, parity, and number of data bits match the weigh scale settings.
- Verify Dataset configuration: two datasets. Dataset 1 is a Floating Point and Dataset set 2 is a 16-bit Uint.



5.4 Verify I/O Communication With Control Studio

- User can create I/O modules in the control studio to verify correct values are read and written between the foreign device into the PSIC. For input data, the values should be changed in the foreign device and verified that the new data are correctly reported.
- To assign a Dataset and a register in the Dataset to an I/O module, follow these steps:
 1. Double click the IO_IN/IO_OUT parameter for the module. This brings up the IO_IN/IO_OUT Property window.
 2. Click on the Browse button. This brings up the Browse window.
 3. Click on the Object_Type drop down list, select All. This displays all the Dataset tags.
 4. Double click on the desired Dataset tag. This assigns the tag to the module and closes the Browse window.
 5. Choose the desired register in the Parameter drop down list.
 6. Click the OK button.

5.5 Using Diagnostics

- Verify PSIC communication: Select the PSIC on Diagnostics and press the right mouse button. Select Display Real -Time Statistics from the drop down menu. If the Programmable Serial Interface Card is functioning then the user will see the Valid Responses counter and the Async and/or Sync Transactions counters incrementing. There will not be any error counting up.
- Verify port statistics: Select the Port on the Programmable Serial Interface Card and press the right mouse button. Then select Display Port Statistics form the drop down menu. Verify that the port communications statistics are being displayed properly and are counting as expected for the protocol's functionality.
- Verify dataset values: Select a dataset and press the right mouse button. Select View Dataset Registers from the Drop down window. Verify that the dataset values are displayed as expected.

5.6 LED Indication

The Yellow LED for the port should be on solid when all communications on that port are valid. The Yellow LED should be blinking if there is some valid communications and some communications with errors on that port. The Yellow LED should be OFF if there are no valid communications on that port.



6 DeltaV–Field Device Electrical Interface

The electrical interface between DeltaV and field devices conforms to the RS-232 and RS-422/485 standards.

Each PSIC has 2 ports. For RS-232 Full-Duplex mode, use the following pin connections.

6.1 Pin Assignments for DeltaV PSIC

Table 3 - RS-232 Standard

Terminal Number	Signal Description
1	Port 1 – Isolated Ground (GND)
2	Unused
3	Port 1 - TXD
4	Unused
5	Port 1 - RXD
6	Unused
7	Port 1 - DTR
8	Port 1 - DSR
9	Port 2 – Isolated Ground (GND)
10	Unused
11	Port 2 - TXD
12	Unused
13	Port 2 - RXD
14	Unused
15	Port 2 - DTR
16	Port 2 - DSR



6.2 Wiring Connections

The figure below shows the connections between the weigh scale RS-232 (assumed 9-pin) port and Port 1 on the Serial Card Termination Block.

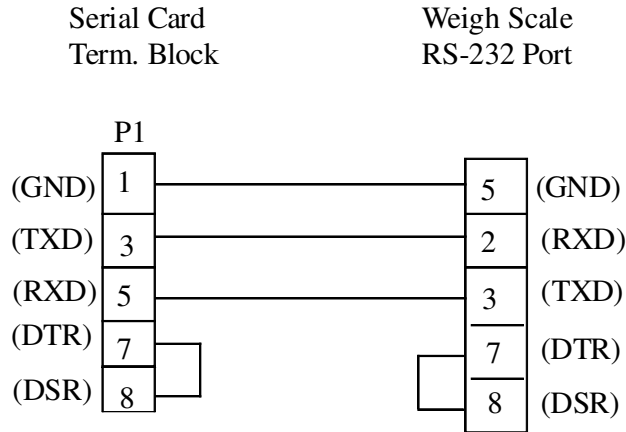



M Y N A HSM

POWERFUL SOLUTIONS FOR DIGITAL PLANTS

7

Technical Support

For technical support or to report a defect, please give Mynah Technologies a call at (636) 681-1555. If a defect is discovered, please document it in as much detail as possible and then fax your report to us at (636) 681-1660.

You can also send us your questions via e-mail. Our address is:

support@mynah.com

Thank you for using DeltaV.