



M Y N A H™

DeltaV / OMNI6 MCC Integrated Testing  
April 5, 2005



## DeltaV Process System Integrated with OMNI6 MCC Using Modbus TCP/IP Protocol Architecture, Integration, and Software Examples





Table of Contents

<b>1</b>	<b>Executive Summary</b>	<b>3</b>
<b>2</b>	<b>System Description and Architecture</b>	<b>4</b>
2.1	Schneider Electric Omni6 Motor Control Center	5
2.2	Emerson DeltaV Process Automation System	5
2.3	Modbus TCP/IP Network Layout	6
<b>3</b>	<b>System Hardware Configuration</b>	<b>7</b>
3.1	DeltaV Virtual IO Module - Modbus Master	7
3.2	Modbus TCP/IP Slave RS485 and Ethernet Devices	7
<b>4</b>	<b>DeltaV System Software Configuration</b>	<b>8</b>
4.1	ATV58 Variable Frequency Drive	8
4.1.1	ATV58 Control Module	8
4.1.2	ATV58 Motor Control Faceplate	9
4.1.3	ATV 58 PID Faceplate	9
4.1.4	ATV58 Motor Detail	10
4.1.5	ATV58 PID Detail	11
4.1.6	ATV58 Graphics Dynamo	11
4.2	FVR and FVNR	12
4.2.1	FVR and FVNR Control Module	12
4.2.2	FVR and FVNR User Interface	13
4.2.3	FVR and FVNR Motor Detail	14
4.2.4	FVR and FVNR Graphics Dynamo	15
4.3	ATV48 SoftStarter	15
4.4	CM4000 Power Monitoring - DeltaV Control Template and User Interface	15
4.4.1	CM4000 - User Interface and Dynamo	16
<b>5</b>	<b>DeltaV Performance and Load Testing</b>	<b>16</b>
5.1	Data Model and Test Setup	16
5.2	Test Results	17
<b>6</b>	<b>Omni6 MCC Device Configuration Reference</b>	<b>17</b>
6.1	Modbus TCP/IP over Ethernet Devices	17
6.2	Modbus Serial RS-485 Devices	18
<b>7</b>	<b>Definitions</b>	<b>19</b>
<b>8</b>	<b>MYNAH Technologies Contact Information</b>	<b>19</b>



## 1. Executive Summary

In continuous and batch process applications the Motor Control Center (MCC) is the integration point for electrical distribution and process control systems. The MCC is a critical point for system design and performance.

Traditionally MCC contained only electromechanical components and all connections were hardwired. Advances in solid state technology has ushered in a revolution with intelligent motor control devices that can be programmed to do more than just turn a motor on and off. These intelligent motor control devices include variable frequency drives, solid state starters, and electronic overload relays. These intelligent motor control devices provide a great deal of data, but transforming these islands of data into useful information presents a major challenge.

Modern communication networks have brought new possibilities for advanced monitoring, diagnostics, and integration with Digital Process Automation Systems. Of the communication networks available, Ethernet offers the greatest opportunity for simplifying wiring, integration with plant information systems for start up and trouble shooting, and efficient integration with the Digital Process Automation System.

This paper documents the integration of Emerson's DeltaV Digital Process Automation System, using PlantWeb Architecture and Technology, with Schneider Electric's OMNI Model 6 MCC system using Transparent Ready Architecture and Technology. These two systems were integrated using Modbus TCP/IP protocol over Ethernet and RS-485.

The deliverables from this paper include integration standards and sample configurations that are free and open source for use on any projects worldwide. These documents are available on the MYNAH Technologies website at [www.mynah.com/network/network\\_application.asp](http://www.mynah.com/network/network_application.asp) and include:

- DeltaV OMNI6 Integration White Paper including hardware, software application configuration.
- DeltaV System Configuration Database Export and Graphics (DeltaV FHX and Operate format).
- Sample System Architecture Drawing (Microsoft Visio 2000 format).
- Sample DeltaV Configuration Standards Documents (Microsoft Word format).
- Sample Installation Factory Acceptance Test Report and Installation Qualification Document (Microsoft Word format).



## 2. System Description and Architecture

The test system is installed at Experitec's headquarters in Chesterfield, Missouri, USA. The following system components were used to test integration between the DeltaV Digital Process Automation System and the OMNI6 Enhanced Motor Control Center (intelligent motor controlling devices) using the Modbus TCP/IP protocol over Ethernet and RS-485.

### DeltaV Integration with OMNI6 MCC Using Modbus TCP/IP

As tested at Experitec, Chesterfield, Missouri, USA

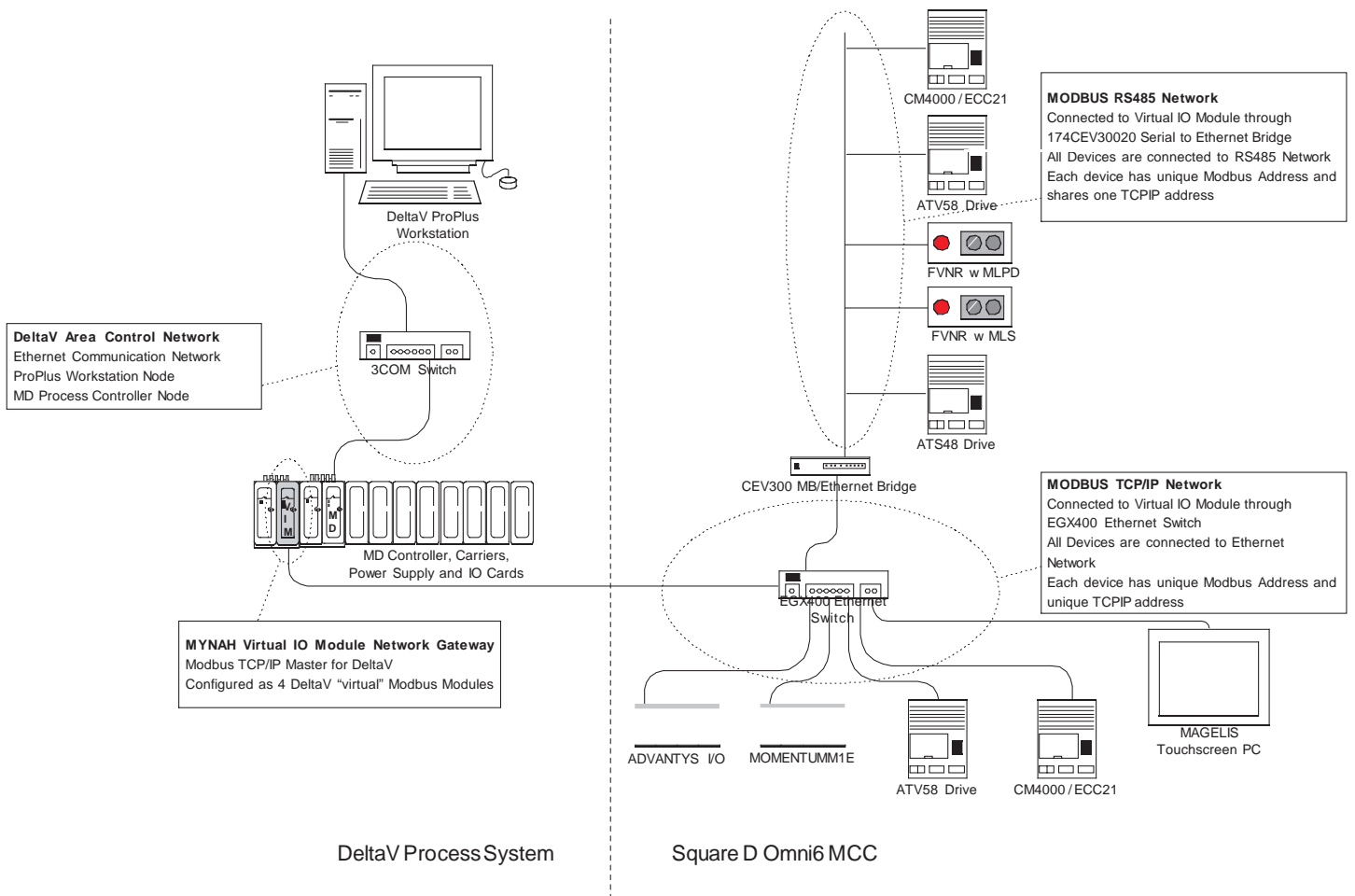



OMNI 6 MCC Cabinet

### 2.1 Schneider Electric OMNI6 Motor Control Center

- OMNI Model 6, double section, 20inch MCC configured with an incoming main circuit breaker; PowerLogic Circuit Monitor, (2) ATV58 VFD's, (2) Overload Relay / combination starter (FVNR, FVR); EGX-400: Advantys I/O; Touchscreen PC, and ATS48.
- The OMNI MCC was configured with a Modbus TCP/IP network over RS-485 and Ethernet connected to hubs with a single port upstream connection to the DeltaV System via the Virtual IO Module.

### 2.2 Emerson DeltaV Process Automation System

- DeltaV Process Automation System Software v7.2.
- DeltaV ProPlus Engineering/Operations Node on Dell Precision workstation.
- DeltaV MD Controller, Power Supply, and 4-Wide Carrier.
- MYNAH Technologies Virtual IO Module with Modbus TCP/IP Master Driver License v1.15.



DeltaV MD Controller  
and  
Virtual IO Module



### 2.3 Modbus TCP/IP Network Layout / Modbus TCP/IP over Ethernet

The MYNAH Technologies Virtual IO Module provides Modbus TCP/IP connectivity to the Ethernet components in the MCC, and functions as the Modbus Master. It provides the signals from the Modbus TCP/IP to the DeltaV Controller as native DeltaV IO Registers. All Ethernet components were connected to an Ethernet switch mounted in the top MCC bucket. Components connected directly via Ethernet to the switch included:

- PowerLogic CM4000 with ECC21
- Schneider Electric ATV58 VFD
- PowerLogic EGX-400 Gateway
- Schneider Electric Momentum M1E CPU
- Grayhill Touchscreen PC
- Advantys IO with Ethernet Communications Module

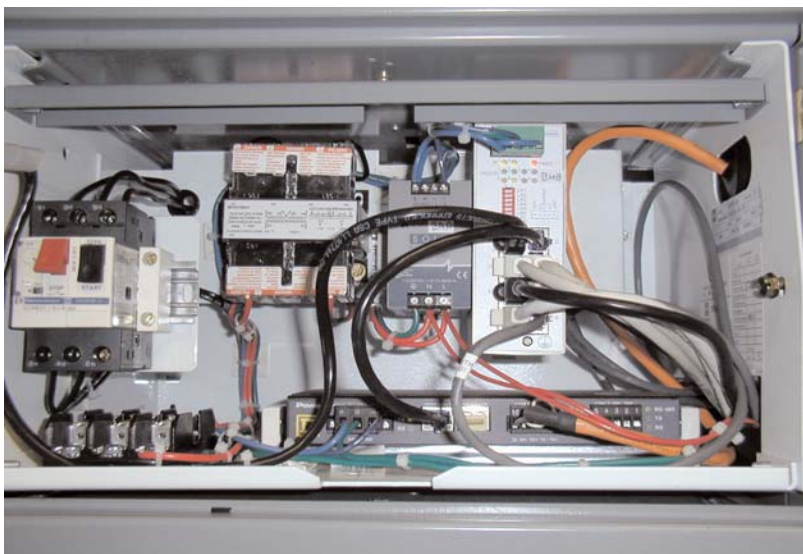

**Modbus TCP/IP Network Switch and Ethernet Serial Gateway**

#### **RS-485 Modbus:**

The Modbus RS-485 Network was connected to Port One of EGX-400 Gateway. The Virtual IO Module communicated to the Modbus devices via the Ethernet TCP/IP port on the EGX-400 Gateway. Components connected directly via Modbus RS-485 to the EGX-400 included:

- PowerLogic CM4000
- Schneider Electric ATV58 VFD
- FVNR starter unit with Motor Logic Plus SSOL and MLPD display unit
- FVNR starter unit with Motor Logic Plus SSOL and MMS display unit
- PowerLogic EGX-400 Gateway
- SoftStarter - ATS48



### 3. System Hardware Configuration

To follow are the system hardware and network configuration settings for the Modbus TCP/IP network between DeltaV and the OMNI6 MCC.

#### 3.1 DeltaV Virtual IO Module - Modbus Master

The DeltaV Virtual IO Module was set up as the Modbus Master with the following settings:

Protocol	Modbus TCP
Virtual DeltaV Modules	57-60
IP Address	10.10.10.20
Hardware Revision	V3.3.2

Four Modbus TCP/IP Slave devices were installed on P01 or C57 as RTU TCP devices using standard port 502.

#### 3.2 Modbus TCP/IP Slave RS-485 and Ethernet Devices

##### RS-485 Modbus:

The RS-485 Network was configured as follows:

- Modbus networking using a trunk/drop line topology
- 19,200 kbaud, 8 data nits, 1 start bit, 1 stop bit
- Modbus RS-485 devices connected to Port 1 of the EGX-400 Gateway

Modbus Device	Modbus Node Address
PowerLogic CM4000	2
FVNR MLPD	3
Schneider Electric ATV58 VFD	4
FVNR MMS	5
ATS48	6

##### Ethernet TCP/IP with Modbus:

The Ethernet Network was configured as follows:

- Ethernet networking using home runs to switch located in EGX-400 Unit
- Data rate set to 10 Mbps
- A single Ethernet connection connects to DeltaV via the Virtual IO Module
- Subnet Mask set to 255.255.255.0
- Gateway/Router IP address set to 0.0.0.0

Ethernet TCP/IP Device	Ethernet TCP/IP Address
EGX-400 Gateway	10.10.10.10
PowerLogic CM4000	10.10.10.11
Schneider Electric ATV58 VFD	10.10.10.12
Advantys IO	10.10.10.13
Momentum M1E CPU	10.10.10.14
PC Touchscreen	10.10.10.15



#### 4. DeltaV System Software Configuration

The DeltaV "Virtual Serial Cards", DeltaV Control Modules and DeltaV Operator Faceplates and Detail displays were configured using the Schneider Electric device communication information as show below.

A wealth of diagnostic and equipment health data is included in each OMNI6 device. In general, all available information was read into DeltaV "Virtual" serial card registers. In general, the DeltaV Module Control Templates were adapted from the standard DeltaV module library and used the operational parameters as required to adequately control and monitor the devices only. The complete DeltaV configuration is available for download on the MYNAH website. The modules included in the sample configuration are open code and can be modified or expanded as required by the user.

##### 4.1 ATV58 Variable Frequency Drive

DeltaV Control Template and User Interface complete description is included in the document: Schneider-vA\_M\_MTR\_ATV58.doc.

##### 4.1.1 ATV58 Control Module

The control module executes in the DeltaV controller and provides regulatory control functions for the ATV58 motor control. The name of the module template is MTR8\_21A.

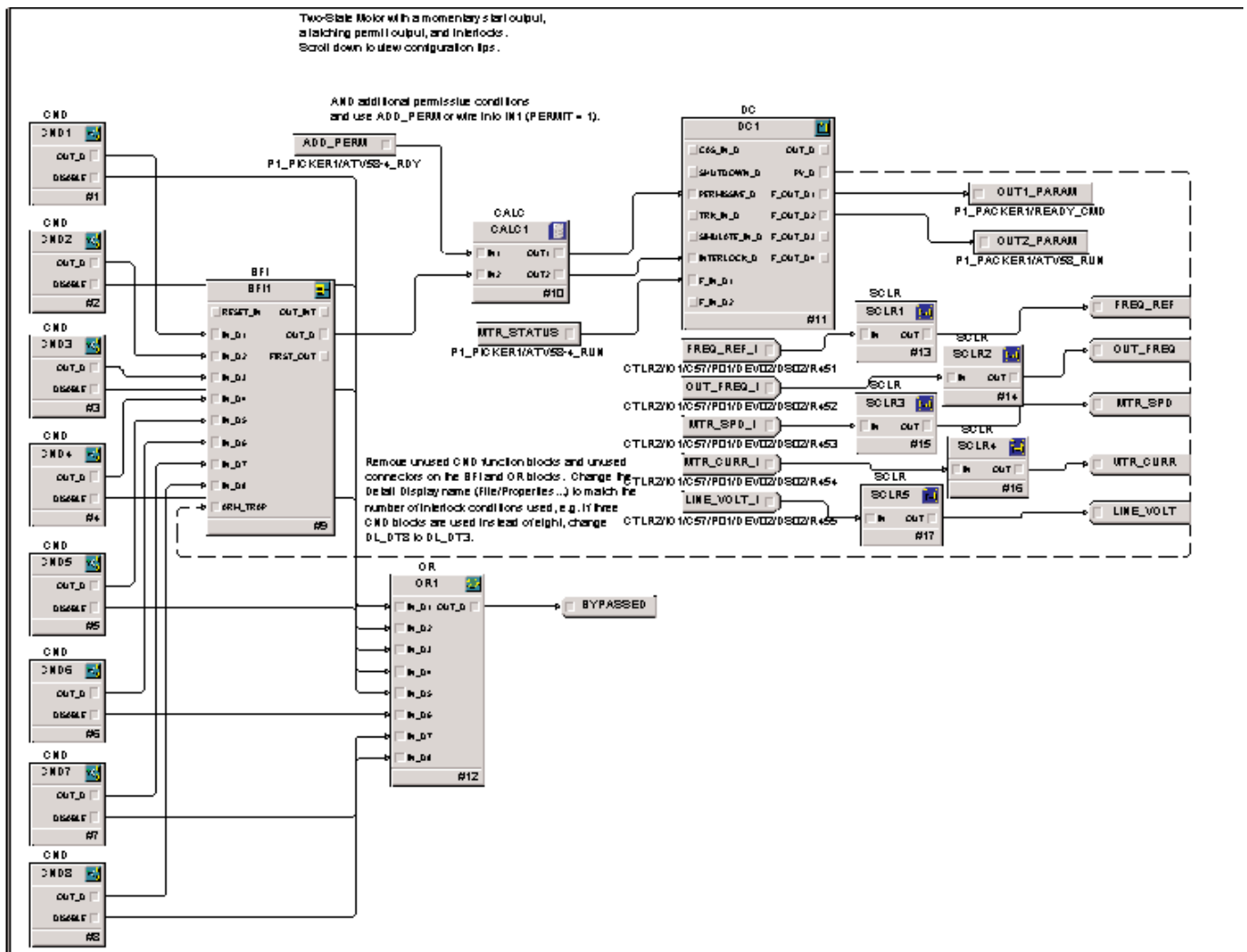



4.1.2 ATV58 Motor Control Faceplate

The operator interfaces with the general module parameters using the faceplate. The display name for the template is the standard DL\_fp.

4.1.3 ATV58 PID Faceplate

The operator interfaces with the general module parameters using the faceplate. The display name for the template is the standard M\_PID4\_fp.

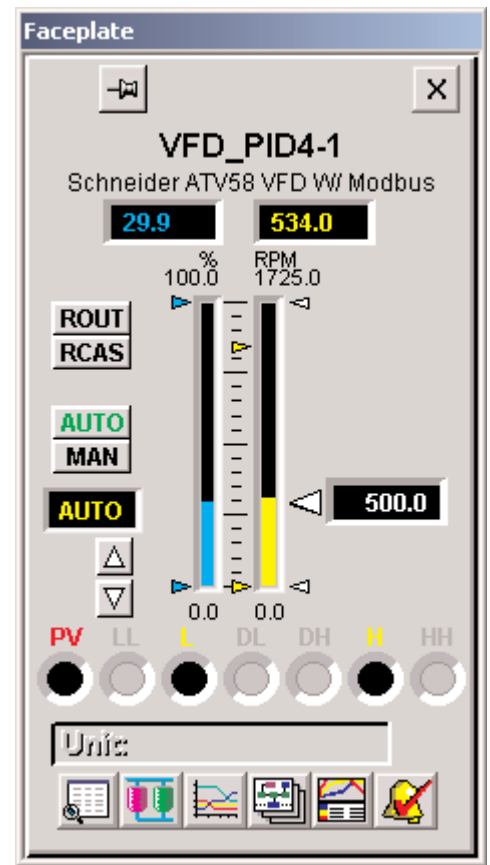



4.1.4 ATV58 Motor Detail

The specific details and diagnostics of module are on the Detail display. The Detail display consists of eight main tabs (Interlock, Permissive, Process Actions, Force Setpoint, Variables, Alm/Lim, I/O, and Diagnose). The detail display name for MTR8\_21\_ATV58 is DLSC\_dt8.

**Detail**

**MTR8\_21**  
Schneider Two-state Motor with mom output and interlocks

**Field Value**  
**RUNNING**

**Limits**

Confirm Time:	Values
Passive	6 s
Active 1	8 s
Active 2	10 s
Trip Time	2 s
Delay Time	0 s
Restart Time	0 s
Crack Time	999 s

**Values**

Freq	13.40
Out Freq	13.30
Speed	399.00
Current	0.20
Volts	488.00

**Alarms**

Fail Alarm: **WARNING**    Enab Supp:

Priority Adj: 0 ...

**Interlocks**

First Out	Condition	Bypass
	Not Used	<input type="checkbox"/>
	Not Used	<input type="checkbox"/>
	Not Used	<input type="checkbox"/>
	Not Used	<input type="checkbox"/>
	Not Used	<input type="checkbox"/>
	Not Used	<input type="checkbox"/>
	Not Used	<input type="checkbox"/>
	Not Used	<input type="checkbox"/>

**Diagnostics**  
MERROR | MSTATUS | BLOCK\_ERR

**Module OK**

**Simulate**

Sim Enable:   
Sim Value: 0

**I/O**

Field Value: 1  
Output Value: 1

Inputs:	Outputs:
1 1	1 1
2 0	2 0
3 0	3 0
4 0	4 0

#### 4.1.5 ATV58 PID Detail

The specific details and diagnostics of module are on the Detail display. The Detail display consists of eight main tabs (Interlock, Permissive, Process Actions, Force Setpoint, Variables, Alm/Lim, I/O, and Diagnose).

The detail display name for ATV58\_VFD\_PID is M\_pid4\_dt.

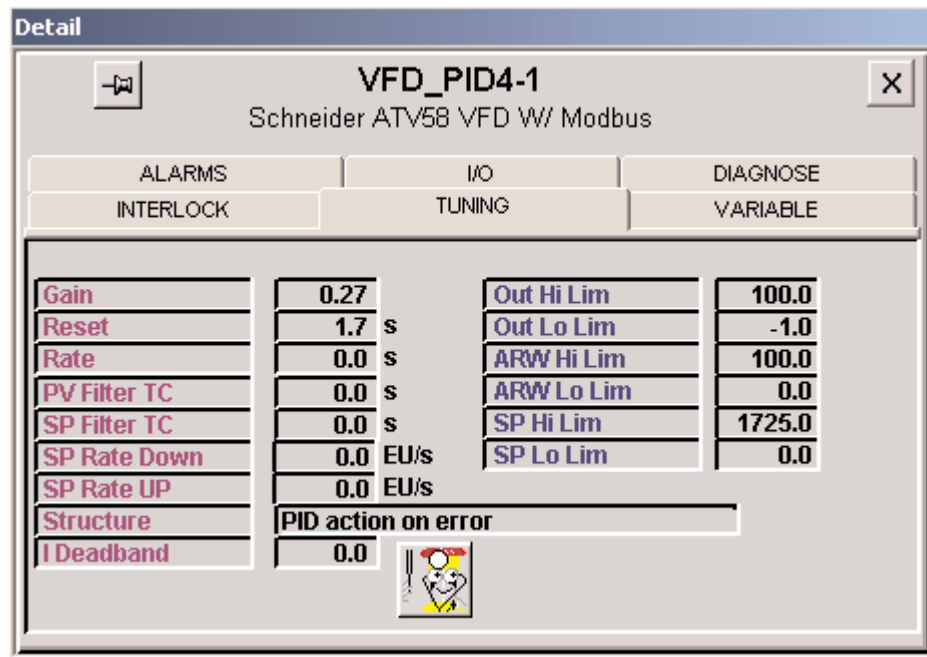

#### 4.1.6 ATV58 Graphics Dynamo

The Dynamo is an object, link, or group of custom built objects, such as pumps and motors, stored in a library used to create pictures in the Graphics Studio program. This is the Dynamo for the MTR8\_21\_ATV58. The Dynamo for the ATV58 resides in a Dynamo Set called Schneider.

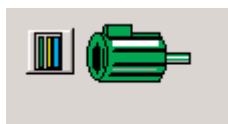

1.

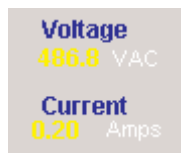

2.

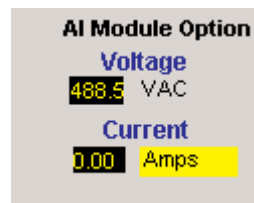

3.

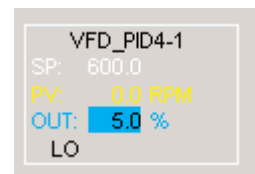

4.



### 4.2 FVR and FVNR

DeltaV Control Template and User Interface complete description is included in the document: Schneider-vA\_M\_MTR\_21FVNR.doc.

#### 4.2.1 FVR and FVNR Control Module

The control module executes in the DeltaV controller and provides regulatory control functions for the FVR and FVNR motor control. The name of the module template is MTR8\_21A.

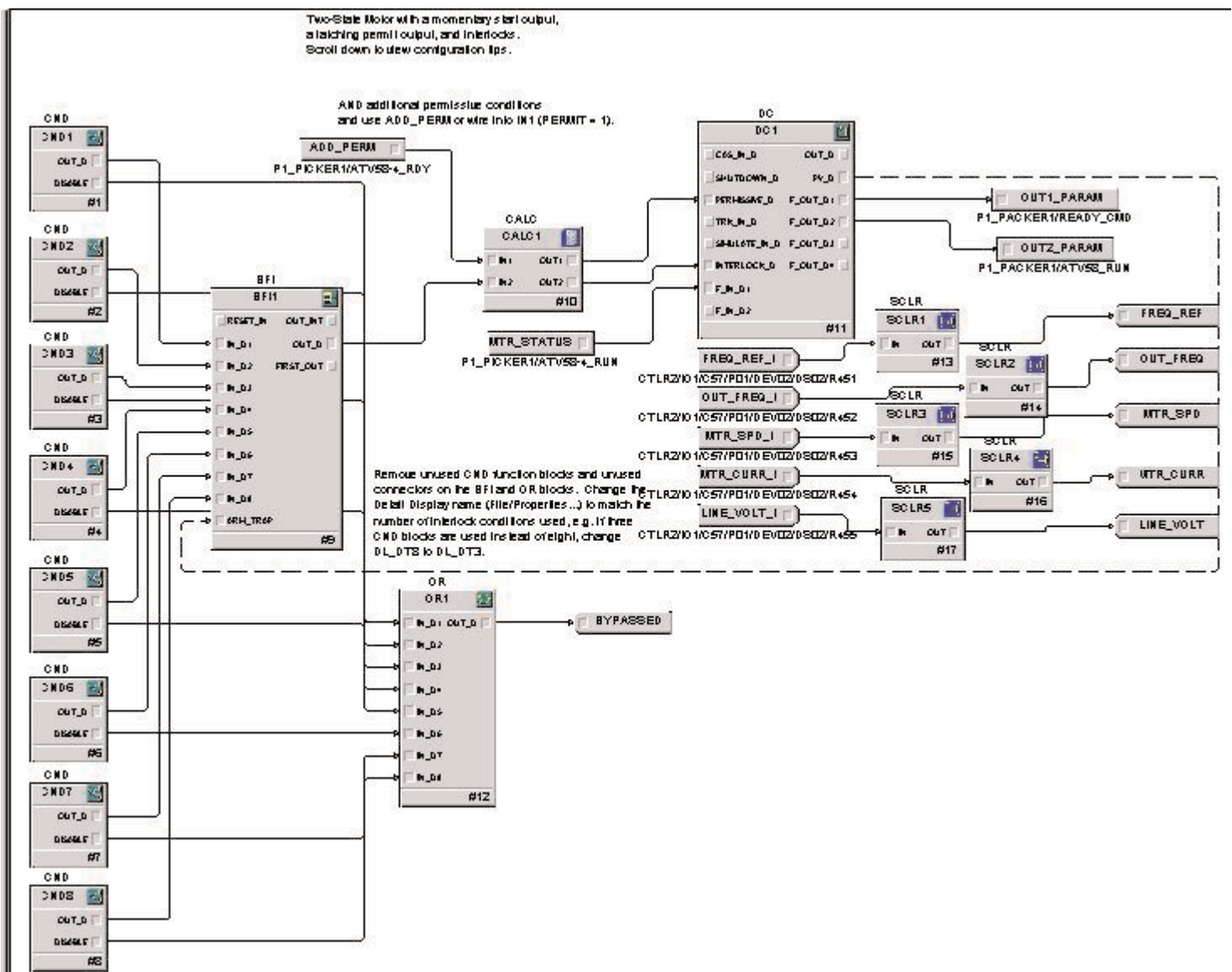

4.2.2 FVR and FVNR User Interface

The operator interfaces with the general module parameters using the faceplate. The display name for the template is the standard DL\_fp.

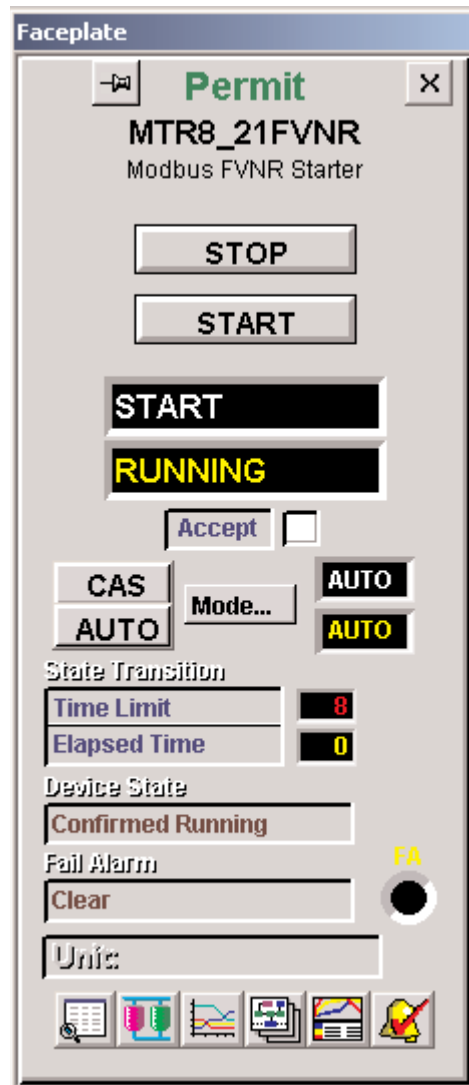



4.2.3 FVR and FVNR Motor Detail

The specific details and diagnostics of module are on the Detail Display. The Detail display consist of eight main tabs (Interlock, Permissive, Process Actions, Force Setpoints, Variables, Alm/Lim, I/O, and Diagnose). The detail display name for MTR8\_21\_ATV58 is DLSC\_dt8.

**Detail**

**MTR8\_21FVNR**  
Modbus FVNR Starter

**Field Value**  
**RUNNING**

**Limits**

Confirm Time:	
Passive	5 s
Active 1	8 s
Active 2	10 s
Trip Time	2 s
Delay Time	0 s
Restart Time	0 s
Crack Time	999 s

**Values**

Current	0.61
Volts	485.00

**Alarms**

Fail Alarm	WARNING	Enab Supp <input checked="" type="checkbox"/>
Priority Adj	0	...

**Interlocks**

First Out	Condition	Bypass
	Not Used	<input type="checkbox"/>
	Not Used	<input type="checkbox"/>
	Not Used	<input type="checkbox"/>
	Not Used	<input type="checkbox"/>
	Not Used	<input type="checkbox"/>
	Not Used	<input type="checkbox"/>
	Not Used	<input type="checkbox"/>
	Not Used	<input type="checkbox"/>

**Diagnostics**

MERROR | MSTATUS | BLOCK\_ERR

**Module OK**

**Simulate**

Sim Enable	<input type="checkbox"/>
Sim Value	0

**I/O**

Field Value	1
Output Value	1

Inputs:	Outputs:
1 1	1 1
2 0	2 0
3 0	3 0
4 0	4 0



4.2.4 FVR and FVNR Graphic Dynamo

The Dynamo is an object, link, or group of custom build objects, such as pumps and motors, stored in a library used to create pictures in the Graphics Studio program. This is the Dynamo for the MTR8\_21\_FVNR. The Dynamo for the ATV58 resides in a Dynamo Set called Schneider.

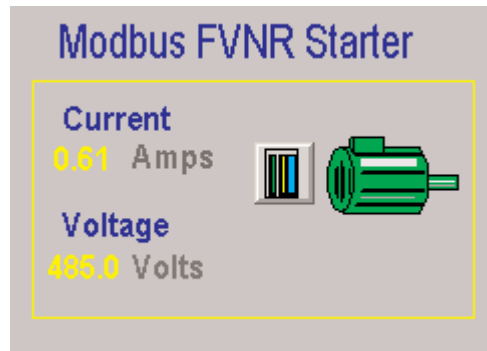

1.

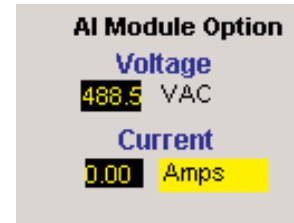

2.

4.3 **ATV48 SoftStarter**

Testing and integration Incomplete at this time.

4.4 **CM4000 Power Monitoring - DeltaV Control Template and User Interface**

The CM4000 Power Monitor was configured to monitor Real Total Power and Current on Phase A, B and C of the MCC as part of the project. Additional variables are available in the CM4000. A complete list can be found in the product manual.

Parameter Name IN	Type	Category	Wired to	Register	Description
CURR_PH_A	External Ref	I/O	--	R1000	MCC Current, Phase A
CURR_PH_B	External Ref	I/O	--	R1001	MCC Current, Phase B
CURR_PH_C	External Ref	I/O	--	R1002	MCC Current, Phase C

Any of the variables listed for the CM4000 can be configured as Analog Inputs if desired to allow for standard alarming and faceplate. The Real Total Power variable was configured as an Analog Input as part of this project, to test the alarming functionality.

Parameter Name Out (Displayed)	Type	Category	Input Range	Output Range
MCC_KW	Floating Point	I/O		0-200

#### 4.4.1 CM4000 User Interface and Dynamo

A Dynamo is an object, link, or group of custom built objects, such as pumps and motors, stored in a library used to create pictures in the Graphics Studio program. This is the Dynamo for the CM4000 used in this project. The Dynamo resides in the Dynamo Set called Schneider.

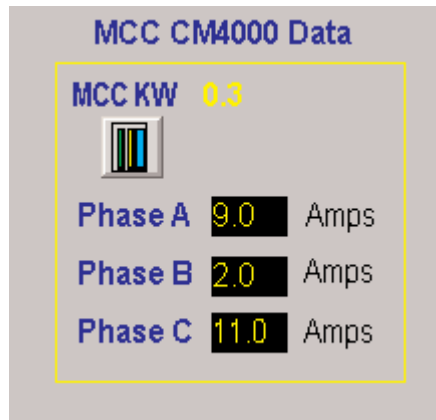

The Dynamo contains the references for MCC Total Real Power (KW) Analog Input information and the Phase A, B and C Current values from the CM4000.

## 5. DeltaV Performance and Loading Testing

Data load testing was performed for the installed system. The testing included documentation of the following DeltaV performance parameter:

- DeltaV Control Free Time
- DeltaV Control Free Memory

Additional Virtual IO Module with the Modbus TCP/IP load testing and performance testing results are available on MYNAH Technologies website at [www.mynah.com/network/network\\_application.asp](http://www.mynah.com/network/network_application.asp).

### 5.1 Data Model and Test Setup

The standard control modules were exercised per the control strategies and the design documents. Changes to the Output DST were monitored and then compared to subsequent changes on the Input DST at the DeltaV Control Module. Please see the following data structure model for the test and communications.

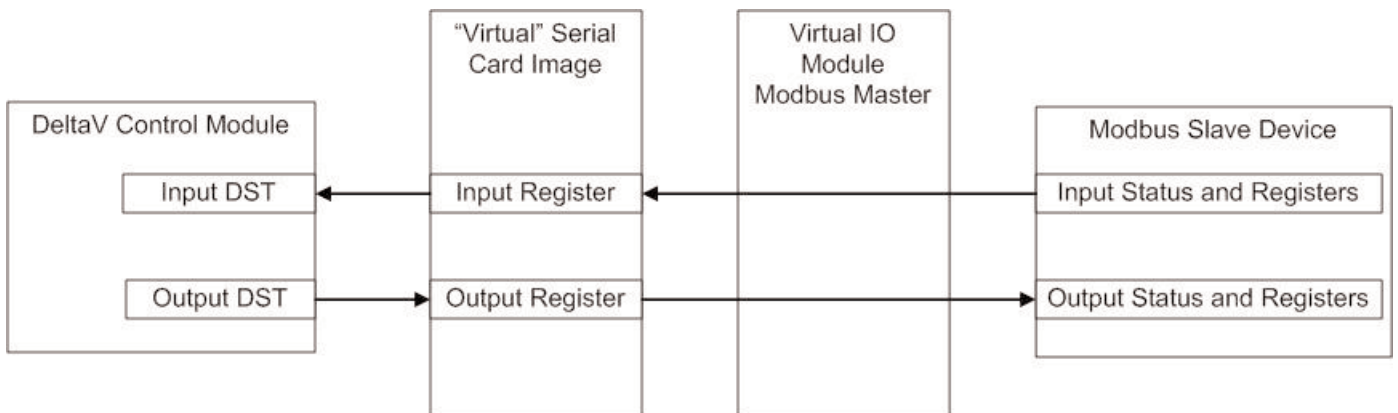



**5.2 Test Results**

Please see the white paper on DeltaV Virtual IO Module Network Performance Testing for complete documentation of Modbus TCP/IP communications IO updates and port scan times benchmarking, on MYNAH Technologies website at [www.mynah.com/network/network\\_application.asp](http://www.mynah.com/network/network_application.asp).

DeltaV Diagnostics were monitored for critical performance data:

- DeltaV Controller Free Time - 97% via DeltaV Diagnostics, with all modules running (total of 19 modules)
- DeltaV Controller Free Memory - 15325669 Bytes.

**6. OMNI6 MCC Device Configuration Reference**

**6.1. Modbus TCP/IP over Ethernet Devices**

<b>Equipment Description</b>	Altivar ATV58 Drive with Ethernet Modbus TCP/IP Communications Card	CM4000 with ECC21 Modbus TCP/IP Communications Card	Advantys STB Distributed I/O	Momentum M1E CPU	TouchScreen Thin Client
<b>Manufacturer</b>	Schneider Electric /Telemecanique	Schneider Electric/Square D Powerlogic	Schneider Electric Telemecanique	Schneider Electric/Modicon	Grayhill
<b>Tested with DeltaV System?</b>	Yes	Yes	Yes	Yes	Yes
<b>Model Name and/or Number</b>	ATV58 with VW3A58310U Card	CM4000 & ECC21	STB NIP 2212	171CCC98020	01YY5021-2
<b>Configuration Software</b>	DeltaV Explorer and MYNAH Technologies VIMNet Explorer				
<b>Data Flow Stream Exceptions</b>	None	None	None	None	None
<b>Dip Switch Configuration</b>	None Required	None Required	None Required	None Required	None Required



6.2. Modbus Serial RS-485 Devices

<b>Equipment Description</b>	Ethernet Modbus TCP/IP Gateway	Alitvar ATV58 VFD with Modbus RS485 Communications	CM4000 with Modbus	Motor Logic Plus SSOLR with Modbus RS485 Communications
<b>Manufacturer</b>	Schneider Electric/Square D Powerlogic	Schneider Electric Telemecanique	Schneider Electric/Square D Powerlogic	Schneider Electric/Square D
<b>Tested with DeltaV System?</b>	Yes	Yes	Yes	Yes
<b>Model Name and/or Number</b>	EGX-400	ATV58 with VW3A58303U Card	CM4000	Motor Logic Plus
<b>Configuration Software</b>	DeltaV Explorer and MYNAH Technologies VIMNet Explorer			
<b>Data Flow Stream Exceptions</b>	None	None	None	None
<b>Dip Switch Configuration</b>	None Required	Device Address See ATV58 Manual	None Required	None Required
<b>Equipment Description</b>	Motor Logic Plus MLPD with Modbus RS485 Communications	Motor Logic Plus MMS with Modbus RS485 Communications	Alitvar ATS48 SoftStarter with Modbus RS485 Communications	
<b>Manufacturer</b>	Schneider Electric Square D	Schneider Electric Square D	Schneider Electric Telemecanique	
<b>Tested with DeltaV System?</b>	Yes	Yes	Yes	
<b>Model Name and/or Number</b>	Motor Logic Plus with 9999MLPD	Motor Logic Plus with 9999MMS	ATS48	
<b>Configuration Software</b>	DeltaV Explorer and MYNAH Technologies VIMNet Explorer			
<b>Data Flow Stream Exceptions</b>	None	None	None	
<b>Dip Switch Configuration</b>	None Required	None Required	None Required	



## 7. Definitions

DCS	Distributed Control System
EDS	Electronic Data Sheet
FAT	Factory Acceptance Testing
FVNR	Full Voltage Non Reversing Motor Starter
FVR	Full Voltage Reversing Motor Starter
IMCC	Intelligent Motor Control Center
IQ	Installation Qualification Protocol
MLP	Motor Logic Plus
ODVA	Open DeviceNet Vendor Association
PCS	Process Control System
SSOLR	Solid State Overload Relay
VFD	Variable Frequency Drive

## 8. MYNAH Technologies Contact Information

Please contact us with any questions about this white paper or other plant floor integration solutions at:

MYNAH Technologies  
504 Trade Center Blvd  
Chesterfield, MO 63005  
1.888.506.9624 (North America)  
1.636.681.1555 (International)  
1.636.681.1660 (fax)  
email: [support@mynah.com](mailto:support@mynah.com)  
[www.mynah.com](http://www.mynah.com)

©MYNAH Technologies 2005. All rights reserved.

MYNAH Technologies and the MYNAH Designs are marks of MYNAH Technologies. Emerson Process Management, DeltaV, and the DeltaV designs are marks of one of the Emerson Process Management of companies. All other marks are property of their respective owners. The contents of this publication are presented for informational purposes only, and while every effort has been made to ensure their accuracy, they are not to be construed as warranties or guarantees, expressed or implied, regarding the products or services described herein or their use or applicability. All sales are governed by our terms and conditions, which are available on request. We reserve the right to modify or improve the design or specification of such products at any time without notice.