



M Y N A HSM

Enron Modbus I/O Driver (Series 2) Programmable Serial Interface Card

USER MANUAL

Rev. P1.10

August 26, 2003

DeltaV is a trademark of Emerson Process Management, Inc © Emerson Process Management, Inc. 1998, 1999.
All rights reserved.

Printed in the U.S.A.

While this information is presented in good faith and believed to be accurate, MYNAH Technologies does not guarantee satisfactory results from reliance upon such information. *Nothing contained herein is to be construed as a warranty or guarantee, express or implied, regarding the performance, merchantability, fitness or any other matter with respect to the products*, nor as a recommendation to use any product or process in conflict with any patent. MYNAH Technologies reserves the right, without notice, to alter or improve the designs or specifications of the products described herein.



1 INTRODUCTION

1.1 Scope

This document is the User Manual for the Enron Modbus I/O serial communication driver firmware for the Emerson Process Management (EPM) DeltaV Control System; it provides information required to install, configure, and maintain the driver firmware on the DeltaV Programmable Serial Interface Card (PSIC). The reader should be familiar with EPM's DeltaV PSIC and connected field devices (supporting the Enron Modbus protocol).

The section *Document Format* briefly describes the contents of each section of this manual. *System Specifications* outlines hardware and software requirements for the Enron Modbus I/O Driver (P1.10) firmware.

1.2 Document Format

This document is organized as follows:

Introduction	Describes the scope and purpose of this document.
Theory of Operation	Provides a general functional overview of the Enron Modbus I/O Driver.
Downloading Firmware	Describes downloading procedures for the Enron Modbus I/O Driver firmware on to the DeltaV PSIC.
Configuration Information	Describes procedures and guidelines for configuring the DeltaV PSIC.
Operational Check	Provides tips and assistance to ensure PSIC is properly setup and configured.
DeltaV-Field Device Electrical Interface	Describes the electrical interface between DeltaV and the Field Device. Also describes the cable pin assignments for RS-232 and RS-422/485 communications.
Technical Support	Describes who to call if you need assistance.
Example	Describes how to configure a device with input and output datasets.



1.3 System Specifications

The following table lists the minimum system requirements for the Enron Modbus I/O Driver:

Table 1: System Specifications

Firmware	Enron Modbus I/O Driver Firmware (P1.10)
Protocol Compatibility	Enron Modbus Protocol is based on the Modbus protocol defined by Gould Modicon in their publication PI-MBUS-300 Rev B. All traffic to and from the RTU's use the ASCII framing message structure. Only reads and writes to 1000, 3000 and 7000 series registers are supported.
Software Requirements	DeltaV System Software (Release 4.2 or later) installed on a hardware-appropriate Windows NT workstation configured as a ProfessionalPlus for DeltaV Serial Interface Port License (VE4102)
Minimum DeltaV Hardware Requirements	DeltaV Series 2 Serial Module, PN: 12P2506X022 DeltaV M3, M5, M5+ or MD Controller, Power Supply and 8 wide controller carrier



2 THEORY OF OPERATION

As part of the serial interface port license, a standard Modbus protocol is installed on the DeltaV PSIC prior to customization. The PSIC needs to be flash upgraded from the Modbus protocol to the Enron Modbus I/O firmware before operation.

The Programmable Serial Interface Card (PSIC) supports RS-232, RS-422/RS-485 Half Duplex and RS-422/RS-485 Full Duplex communications with external devices. For communications with Enron Modbus devices, any of these methods can be utilized. The electrical connection and communication settings must be configured properly to ensure accurate communication between the PSIC and field devices. These are described in Section 4.1.

The primary functions of the driver are listed below:

- Performs data and message handling between DeltaV and field devices.
- In Master mode, sends read/write commands to the field device, checks validity of responses received, and updates the corresponding DeltaV PSIC registers.
- In Slave mode, receives read/write commands from the field device, checks validity of command received, formats a response to send back, and updates the corresponding DeltaV PSIC registers.

Each PSIC, when loaded with the Enron Modbus I/O Driver, is capable of communicating with field devices over one or both of its two ports, depending upon your application.

Default message framing is ASCII. To get RTU framing, see Section 4.3.6.

3 Downloading the firmware

The driver software distribution comprises 15 files, distributed on a CD. These files must be copied to the DeltaV directory on your ProPlus Workstation. The path is:

\DeltaV\ctl\ProgSerial\S2-Enron

Note that you will have to create the \S2-Enron subdirectory.

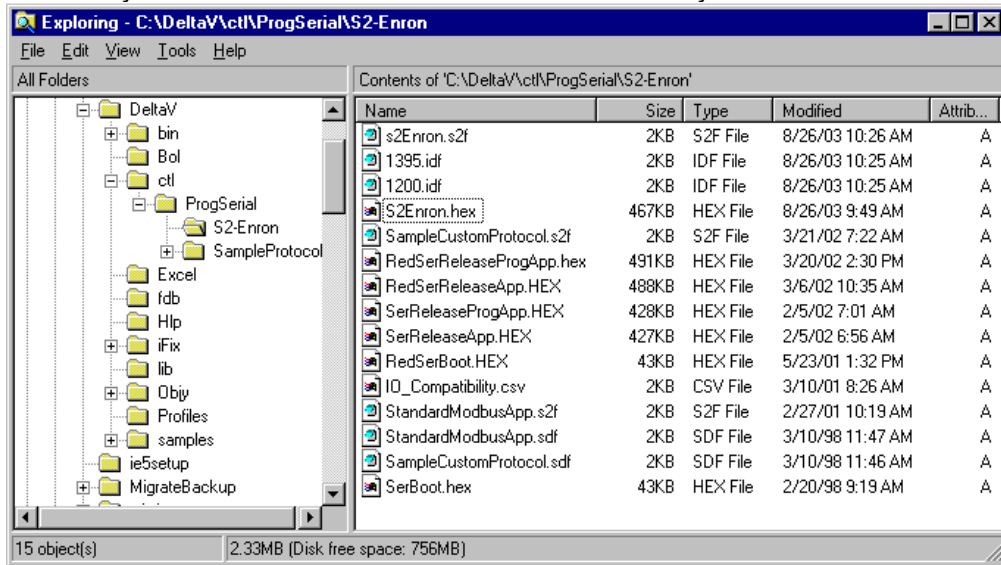

After copy completion, you are ready to program (or upgrade) the Programmable Serial Card with the supplied custom driver software. The steps are as follows:

1. Click on the Start button and select DeltaV-> Installation-> Controller Upgrade Utility as shown below, and the following dialog will appear:

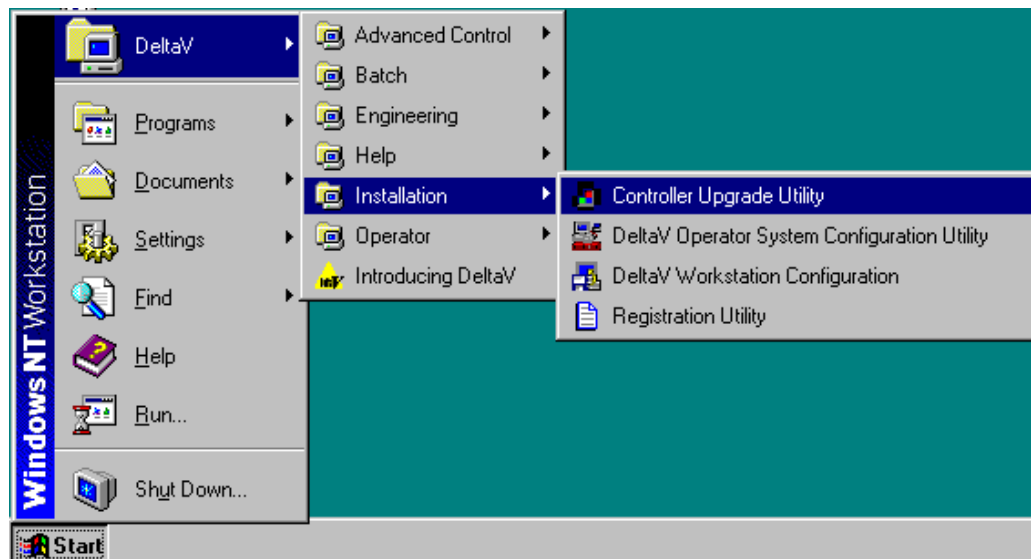

2. Click on the Upgrade I/O Modules radio button, and then click Next.

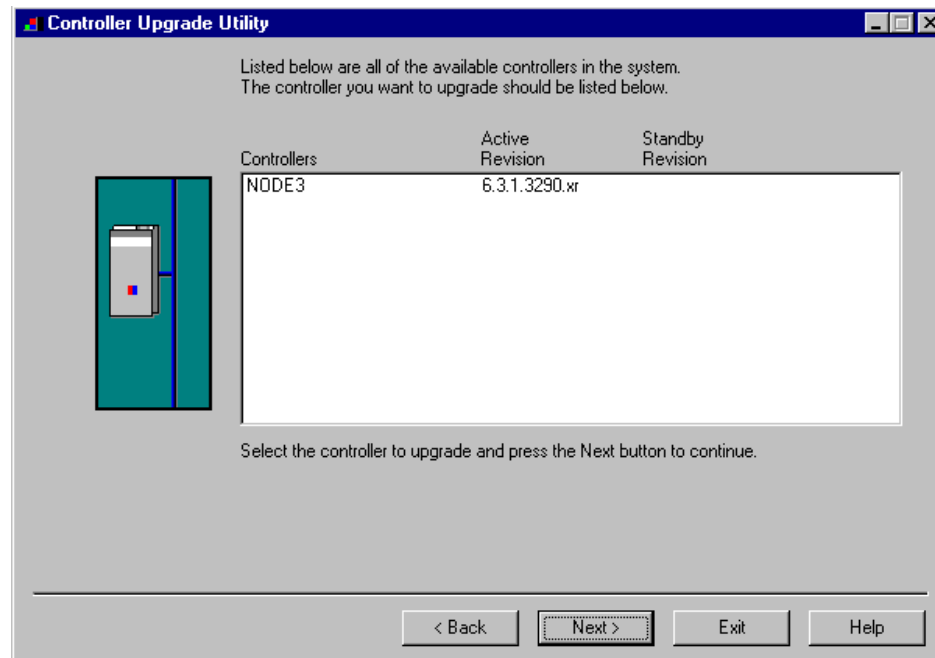
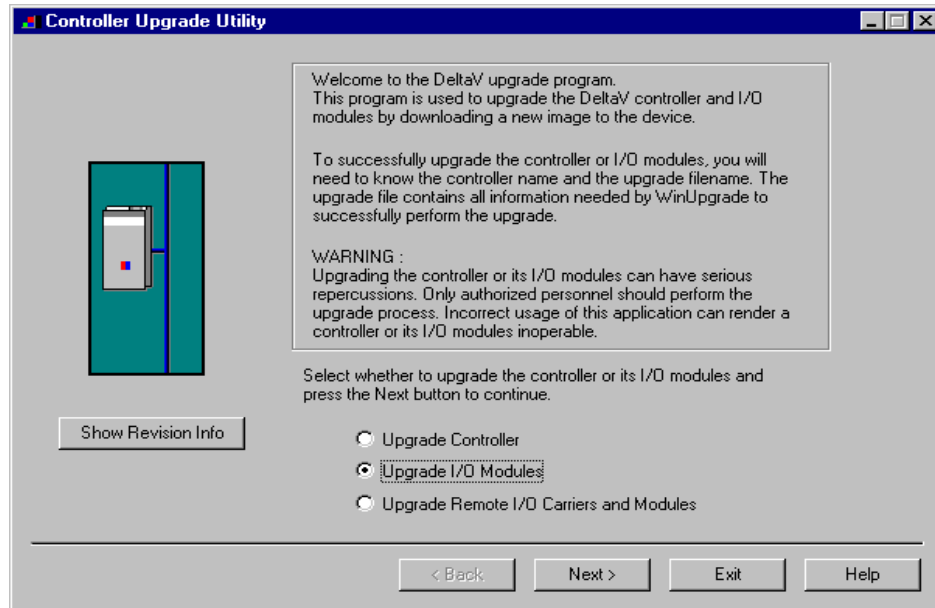

3. The above dialog will appear, listing all the available Controllers in your network. From this dialog, select the appropriate Controller and then Click Next.

4. The following dialog will appear, listing all the I/O modules in your selected Controller. The shown list of I/O modules is an example only. Your list will be different.

Note: The first time a standard Serial card is upgraded to the Enron Modbus I/O Driver, the dialog will be as shown below. When upgrading an existing Programmable Serial Card, skip Steps 4, 5 and 6, and go to Step 7.

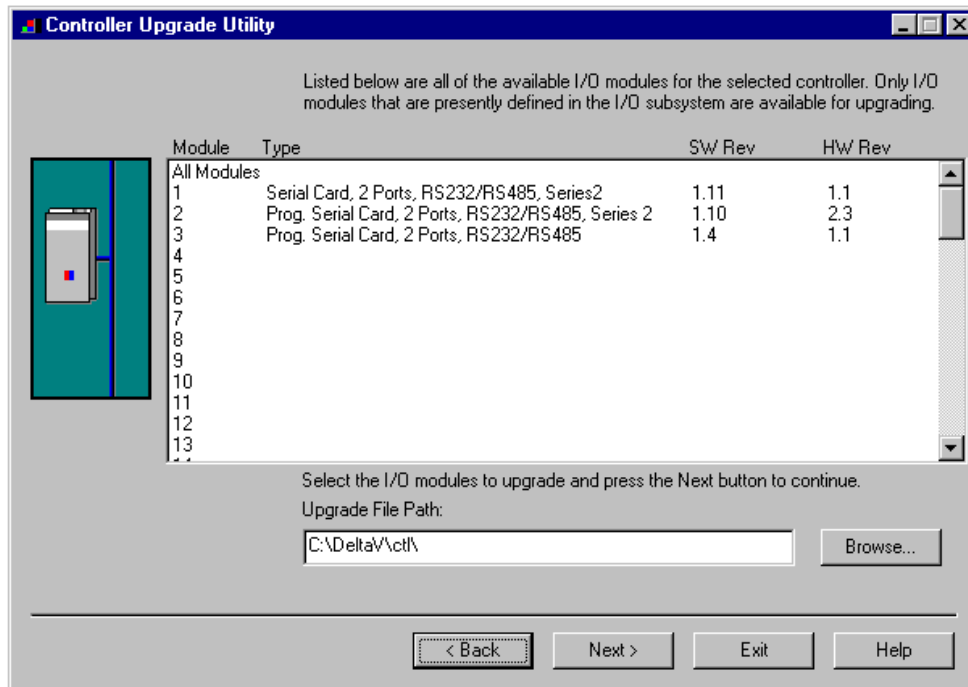

5. Click the Browse button and select the DeltaV path as shown below, and then click Ok. Note that the disk drive could be C or D.

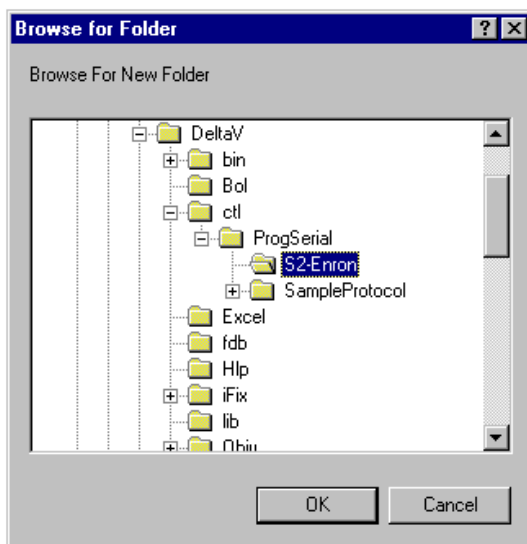

6. Select the I/O module again as shown below and then click Next. Go to Step 9.

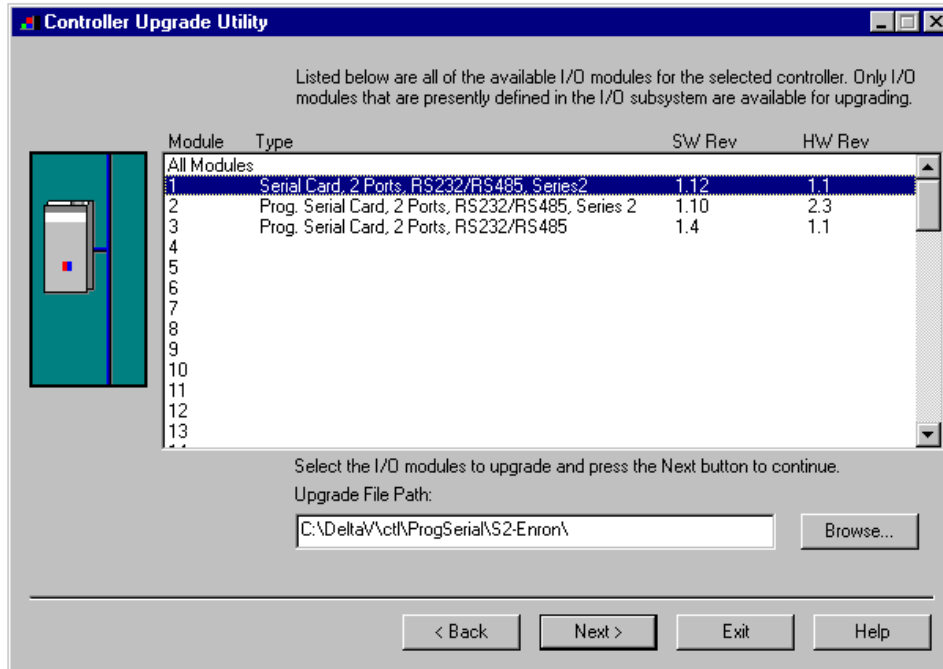

7. If you are upgrading an existing Programmable Serial Card, the dialog will be as shown below. From this dialog, select the Programmable Serial Card I/O Module in the list.

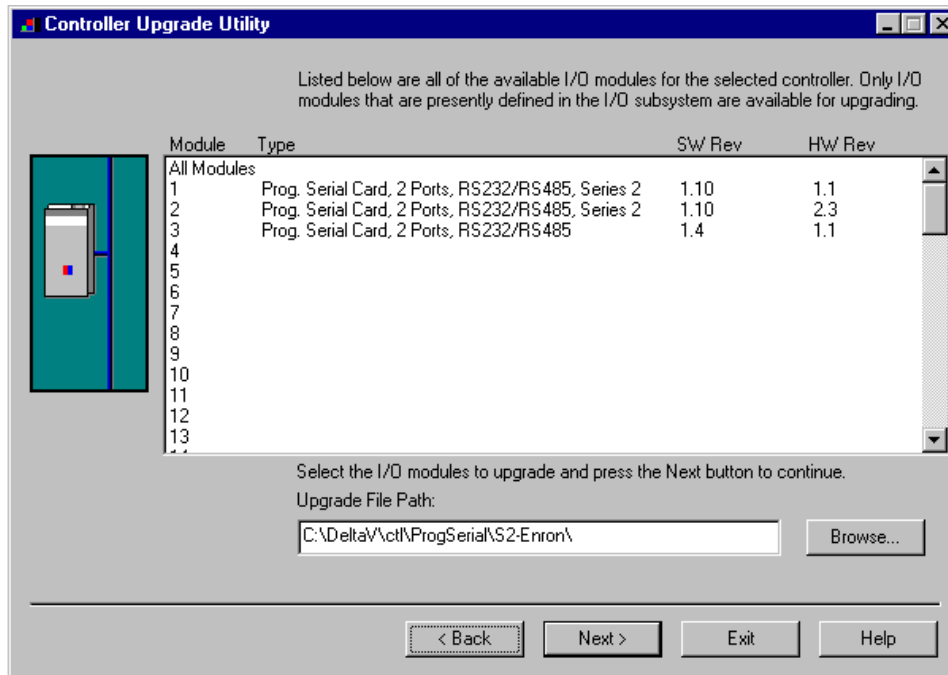

For example, we will select I/O Module 1. This will give you a dialog, from which you will select the file path to where the driver software is located. This path will be:

\\Delta\Vct\ProgSerial\S2-Enron.

Once you are in the specified directory, you will need to select the following file:

S2Enron.S2F

This is shown in the following dialog.

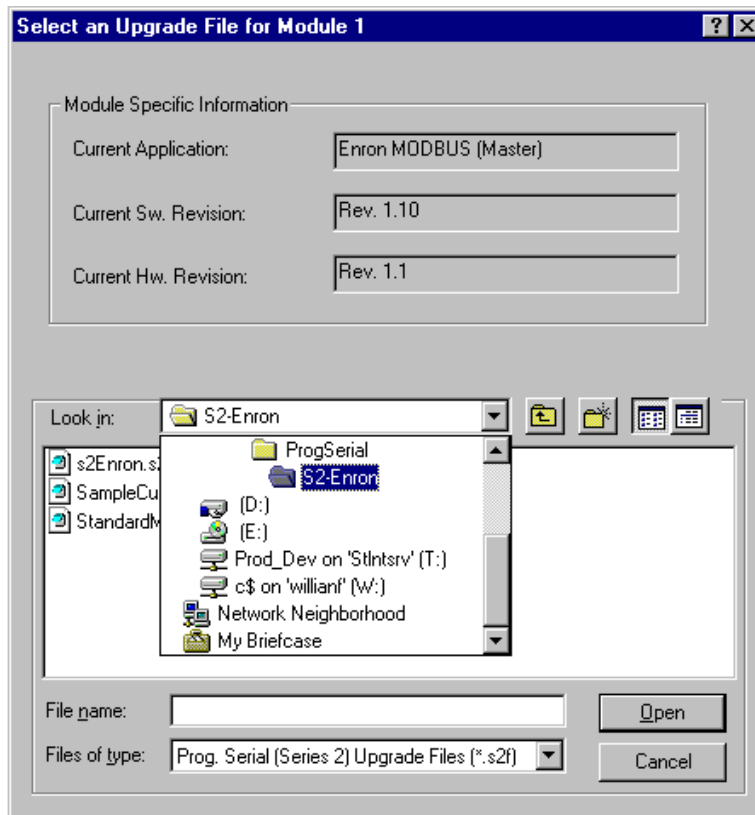

8. After selecting the .S2F file, Click on Open. This dialog will close and you will be back to the following:

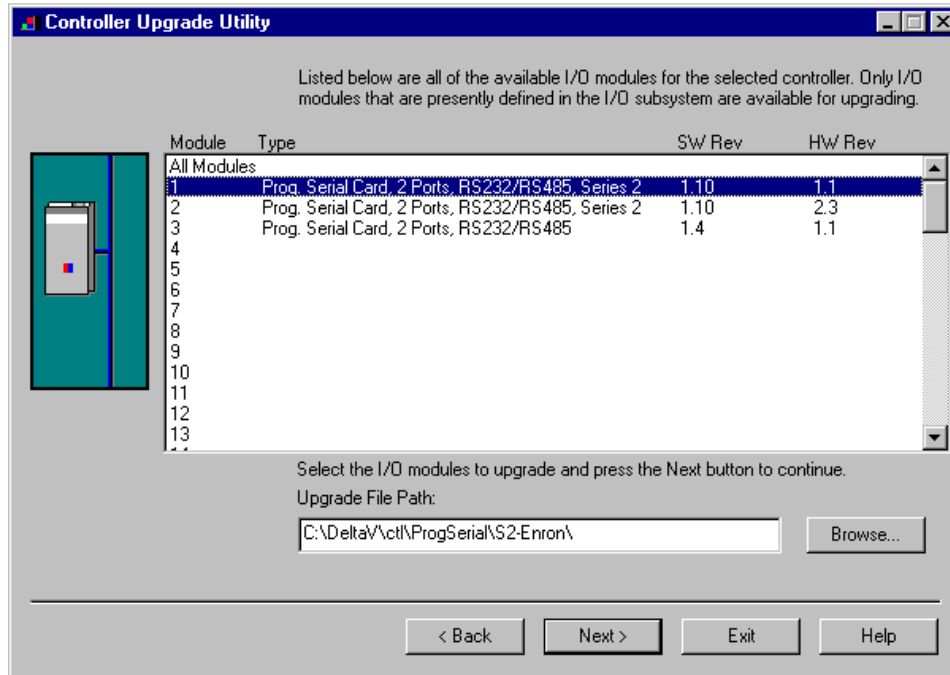

9. In this dialog, Click Next again. You will get the following dialog, confirming the Controller and I/O Module to program.

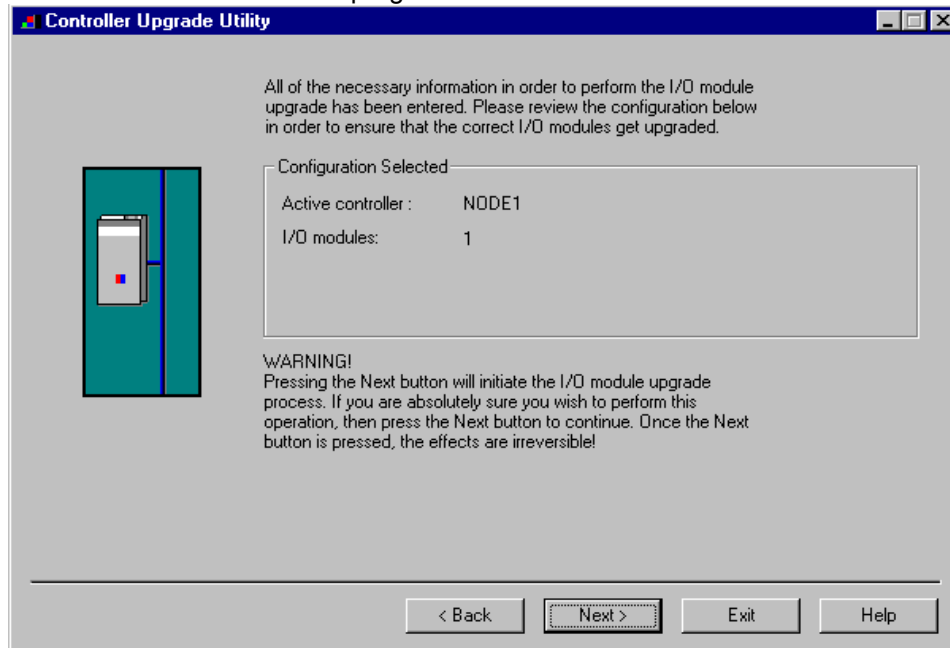

10. Click Next and the I/O Module upgrade process will begin. After completion, you will receive the following dialog, indicating success.

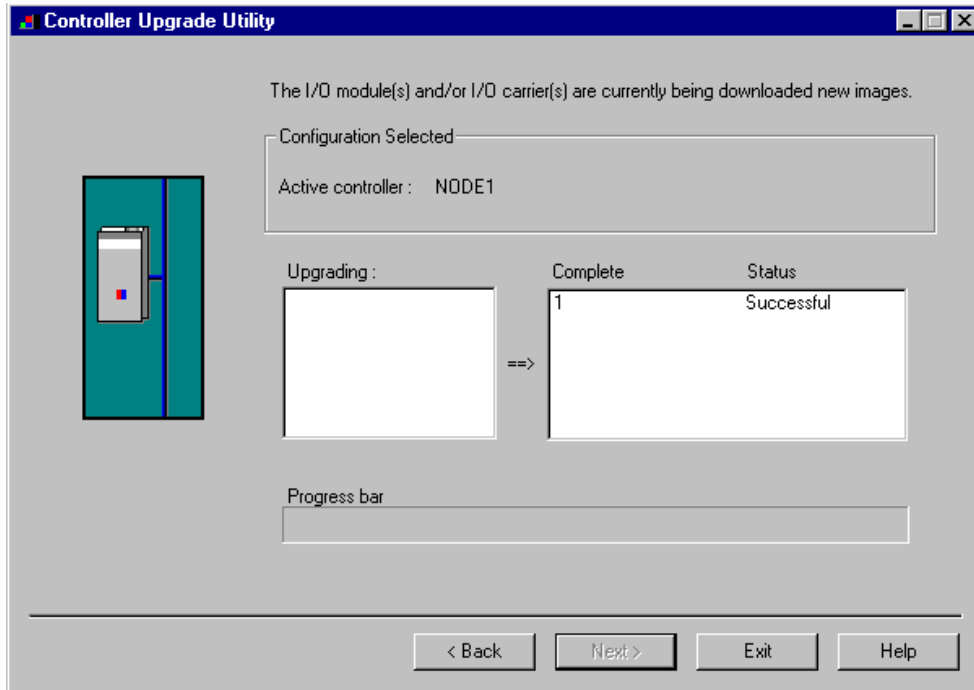

11. This completes the I/O Module upgrade process.

The following sections describe configuration details for the PSIC. Section 8 provides a more specific (and pictorial) step-by-step guide to the configuration.

4.1 Port Configuration

First, enable the port. Then click on the Advanced Tab and select Master or Slave. If Master is selected, also specify the retry count, message timeout value in milliseconds, and message delay time. In most cases, you can leave these at their default values. Next, click on the Communications Tab and specify the Port type. The Port type will be RS-232, RS-422/485 Half Duplex (2 wire), or RS-422/485 Full Duplex (4 wire). Select RS-232 for point-to-point communications; select RS-422/485 if connected to multi-dropped RTU's. Lastly, select the Baud rate, Parity, Data bits and Stop bits parameters; these must match the RTU settings.

4.2 Device Configuration

Specify devices, one for each RTU. The device address must match the RTU address.

4.3 Dataset Configuration

In Master mode, Datasets contain the field values read from an RTU or DeltaV values being written to an RTU. In Slave mode, Datasets are the tables, which will be read or written by the Enron Modbus Master.

4.3.1 Data Direction:

The Data Direction for dataset should be defined as Input or output. This parameter is available only under Master mode.

4.3.2 Output Mode:

Two output modes are available in the DeltaV PSIC: block output (0) and single value output (1). In block mode, any register change in the dataset will trigger the entire dataset to be written to the RTU. In single value mode, only the changed register is written out.

The selected mode is dependent on the field device, whether it supports block output or not, and on your specific application. Please refer to the field device documentation. This parameter is available only under Master mode.

4.3.3 DeltaV Data Type:

The type of Enron Modbus register being mapped will determine the Dataset Data Type. This is described in the following table:

Table 1

Enron Register Type	Dataset Register Type
1000 Series	Boolean with status
3000 Series	16 bit UINT with status
5000 Series	32 bit UINT with status
7000 Series	Floating point with status

4.3.4 DeviceDataType

The DeviceDataType determines which Enron Modbus command is being sent to the RTU. This is described in the following table:

Table 2

Device Data Type	Data Direction	Enron Modbus Command Type
0	Input	1– Read Discrete I/O Status Points (1000 Series Registers)
1	Input	3– Read Analog I/O Points (Floating Point Values-7000 Series Registers, and 32-bit values – 5000 Series Registers)
2	Input	3– Read Analog I/O Points (16-bit Unsigned Integer Values, 3000 Series Registers)
0	Output	5– Force Single Discrete Output Point to ON or OFF. This command is sent when using single value Output Mode. 15– Force Multiple Discrete Output Points to ON or OFF. This command is sent when using Block Output Mode.
1	Output	6– Sets a single Analog floating point value. This command is sent when using single value Output Mode. 16– Sets multiple Analog floating point values. This command is sent when using Block Output Mode.
2	Output	6– Sets a single Analog 16-bit value. This command is sent when using single value Output Mode. 16– Sets multiple Analog 16-bit values. This command is sent when using Block Output Mode.

4.3.5 Data Start Address and Number of Values

The Start Address for each dataset should be configured to match the Enron Modbus registers it reads or writes. In Slave mode, the Start Address must be unique and non-overlapping with other datasets. Note that since the dataset registers are indexed starting with 1, the Start Address must be configured such that (Start Address + 1) is the first Enron Modbus register being accessed.

The Number of values maximum for a dataset is 100, if mapping 1000 series Enron Modbus registers, 60 for 3000 Series registers, and 30 when mapping 7000 series registers.

The following table shows some examples.

Table 3

Start Address	Number Of Values	First Enron Modbus Register	Last Enron Modbus Register
1000	100	1001	1100
1019	20	1020	1039
7000	30	7001	7030
7030	30	7031	7100
3000	60	3001	3060
3060	20	3061	3080

4.3.6 Special Data 1-5

Under the Special data tab, the Special data 1 value is used for 7000 series register data I/O. This data is always transferred as floating point numbers encoded in IEEE format. Floating point numbers are represented in 4 bytes. The byte order of the number is dependent on how the field device stores and transmits it in the command/response packet. In the PSIC, you can change how DeltaV interprets the number by specifying a 0 or 1 in Special data 1 as described below. For example, a 1.0 is represented as 0x3F800000. The PSIC will look at this number as described: Check the field device documentation before configuring this value.

Table 4

Special Data 1	Byte Order
0 (default)	0x3F, 0x80, 0x00, 0x00
1	0x00, 0x00, 0x80, 0x3F

Default message framing for Enron Modbus is ASCII. Use the Special data 2 value to change the framing to RTU as described below.

Table 5

Special Data 2	Message Framing
0 (default)	ASCII Framing
1	RTU Framing

All other Special Data values are unused.



5 Operational Check

5.1 Scope

The following sections provide some assistance to ensure the interface is working properly.

5.2 Verify Hardware and Software Version Number

The user can verify that the Enron Modbus I/O driver has been installed using the DeltaV Diagnostics tool. The Diagnostics tool will show the Hardware Revision No. (HwRev) and the Software Revision No. (SwRev).

To begin the DeltaV Diagnostic tool select Start-> DeltaV-> Operator-> Diagnostics. In the Diagnostics tool expand the Controller, I/O and then double click on the Programmable Serial Interface Card that has the driver installed.

The following information will be displayed:

:	:	:
HwRev	Hardware Revision	1.1 (or later)
SwRev	Software Revision	P1.10 (or later)

5.3 Verify Configuration

- Verify port configuration: The serial port must be enabled. User needs to make sure communication settings such as baud rate, parity, and number of data bits match the field device settings.
- Verify dataset configuration: The datasets configured must be as shown above.

5.4 Verify I/O Communication With Control Studio

User can create I/O modules in the control studio to verify correct values are read from the PSIC. For AI and DI data, the values should be changed in the field device and verified that the new data are correctly reported in DeltaV. Similarly, verify that the AO and DO data is being written correctly from DeltaV to the field device.

5.5 Using Diagnostics

- Verify PSIC communication: Select the PSIC on Diagnostics and press the right mouse button. Select Display Real -Time Statistics from the drop down menu. If the Programmable Serial Interface Card is functioning then the user will see the Valid Responses counter and the Async and/or Sync Transactions counters incrementing. There will not be any error counting up.
- Verify port statistics: Select the Port on the Programmable Serial Interface Card and press the right mouse button. Then select Display Port Statistics form the drop down menu. Verify that the port communications statistics are being displayed properly and are counting as expected for the protocol's functionality.

- Verify dataset values: Select a dataset and press the right mouse button. Select View Dataset Registers from the Drop down window. Verify that the dataset values are displayed as expected.

5.6 LED Indication

The Yellow LED for the port should be on solid when all communications on that port are valid. The Yellow LED should be blinking if there is some valid communications and some communications with errors on that port. The Yellow LED should be OFF if there are no valid communications on that port.



6 DeltaV–Field Device Electrical Interface

The electrical interface between DeltaV and field devices conforms to the RS-232 and RS-422/485 standards.

Each PSIC has 2 ports, which function independently. The distance between the serial card and the field device can be as much as 5000 feet, per the RS-422/485 standard. When using RS-232, the distance is limited to 50 feet. Section 6.1 shows the pin assignments for the PSIC serial terminal block.

6.1 Pin Assignments for DeltaV PSIC

RS-232 Standard

Terminal Number	Signal Description
1	Port 1 - Isolated Ground (GND)
2	Unused
3	Port 1 – Transmit Data (TxD)
4	Unused
5	Port 1 – Receive Data (RxD)
6	Unused
7	Port 1 – Data Terminal Ready (DTR)
8	Port 1 – Data Set Ready (DSR)
9	Port 2 - Isolated Ground (GND)
10	Unused
11	Port 2 – Transmit Data (TxD)
12	Unused
13	Port 2 – Receive Data (RxD)
14	Unused
15	Port 2 – Data Terminal Ready (DTR)
16	Port 1 – Data Set Ready (DSR)



RS-422/485 Half Duplex Standard

Terminal Number	Signal Description
1	Port 1 - Isolated Ground (GND)
2	Port 1 - Data +
3	Unused
4	Port 1 - Data -
5	Unused
6	Unused
7	Unused
8	Unused
9	Port 2 - Isolated Ground (GND)
10	Port 2 - Data +
11	Unused
12	Port 2 - Data -
13	Unused
14	Unused
15	Unused
16	Unused

RS-422/485 Full Duplex Standard

Terminal Number	Signal Description
1	Port 1 - Isolated Ground (GND)
2	Port 1 - TxD +
3	Unused
4	Port 1 - TxD -
5	Unused
6	Port 1 - RxD +
7	Unused
8	Port 1 - RxD -
9	Port 2 - Isolated Ground (GND)
10	Port 2 - TxD +
11	Unused
12	Port 2 - TxD -
13	Unused
14	Port 2 - RxD +
15	Unused
16	Port 2 - RxD -



6.2 Wiring Connections

In general, the figure below shows the connections between the Field Device and the PSIC termination block. In some cases, RxD and TxD signals need to be swapped to create a NULL cable. This can be done easily at the PSIC termination block.

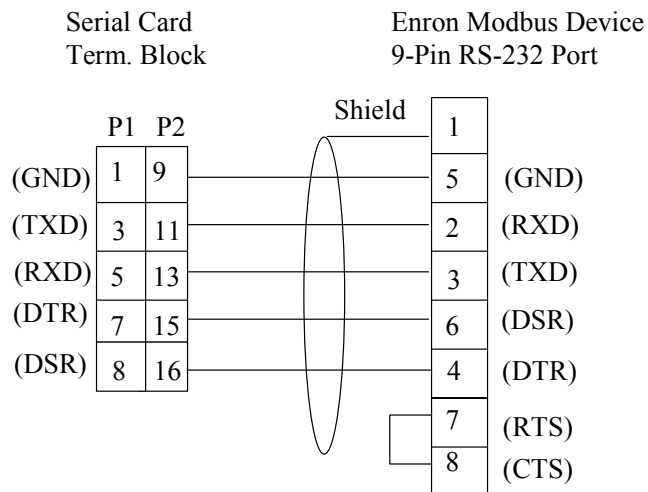
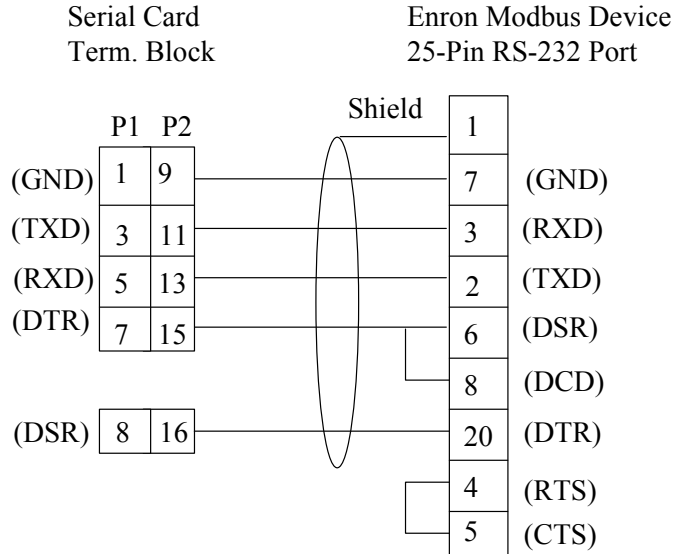

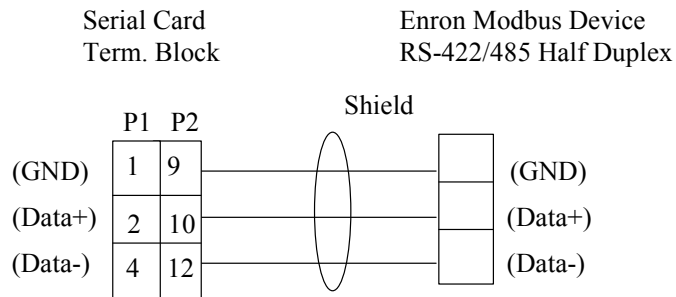
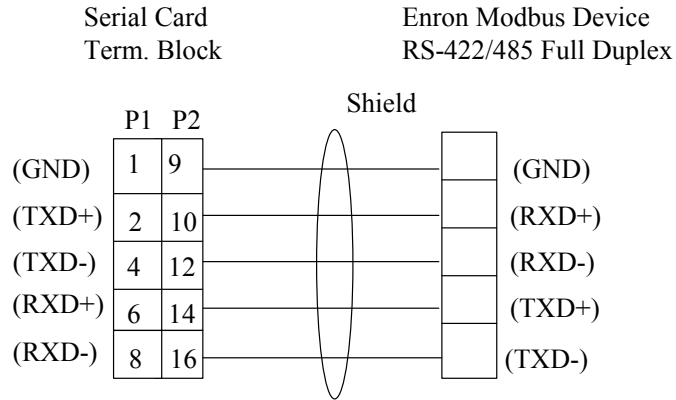



7 Technical Support

For technical support or to report a defect, please give MYNAH Technologies a call at (636) 681-1555. If a defect is discovered, please document it in as much detail as possible and then fax your report to us at (636) 681-1660.

For Product functionality questions, ask for the people in the following order:

1. Nobin William
2. Dean Cook

For Commercial issues, ask for people in the following order:

1. Martin Berutti
2. Jane Wagner

For all other driver and related questions, ask for Nobin William.

You can also send us your questions via e-mail. Our addresses are:

support@mynah.com

Thank you for using DeltaV.



8 Example

8.1 Configuration for PSIC

In this configuration, Card 1 is added, and 1 Device is defined under Port 1.

Step 1:

In the DeltaV Explorer, Right Mouse Click on the I/O entry and select New Card. The following dialog will appear. In this dialog, select Slot Position. In this example, we selected position 01. Click OK to continue.

Add card [?] [X]

Object type: Card [OK]

Modified: -- [Cancel]

Modified by: --

Description:
Enron Modbus

I/O Card

Card class :
Serial Cards

Card type :
2 Ports, Programmable, RS232|RS485

Card series :
Series 1

Features:
Basic Functionality

I/O Redundancy
 Card is redundant

Slot position:
01

Step 2:



The new card will be added with 2 ports, P01 and P02. Next, Right Mouse Click on port P01, and select Properties as follows:

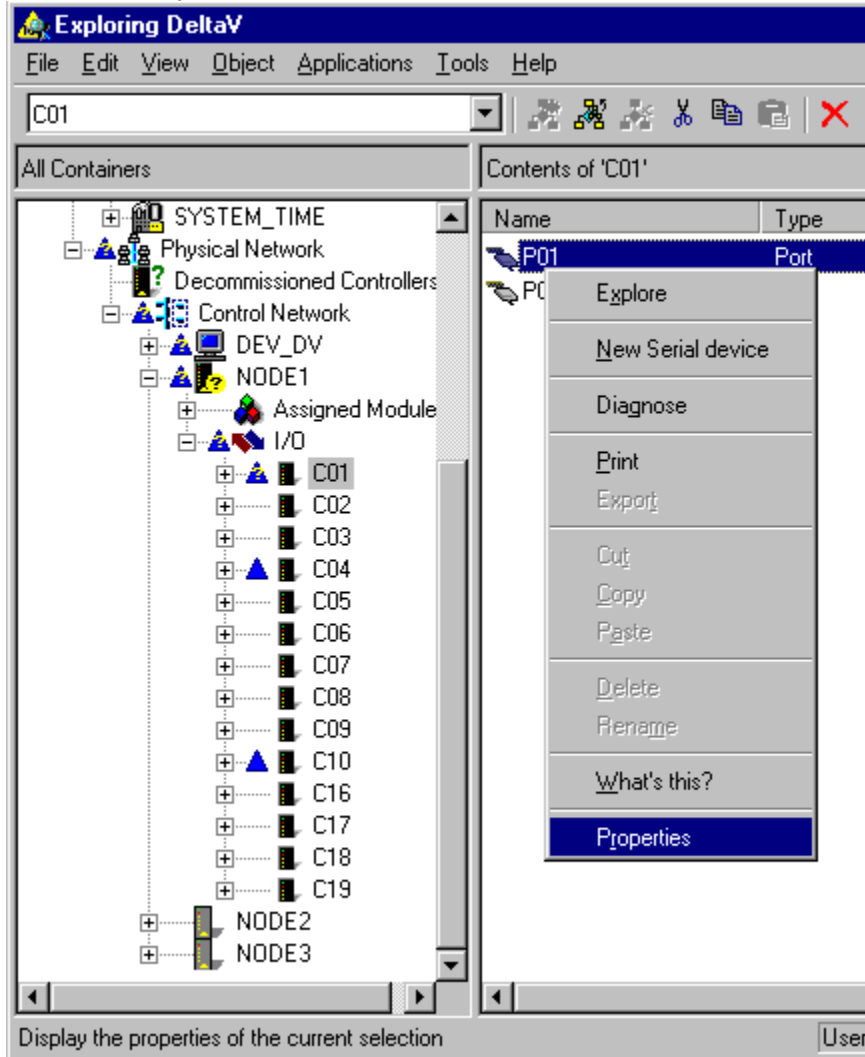

When Properties are selected, the following dialog will appear, allowing you to configure the port. Configure the values as shown.

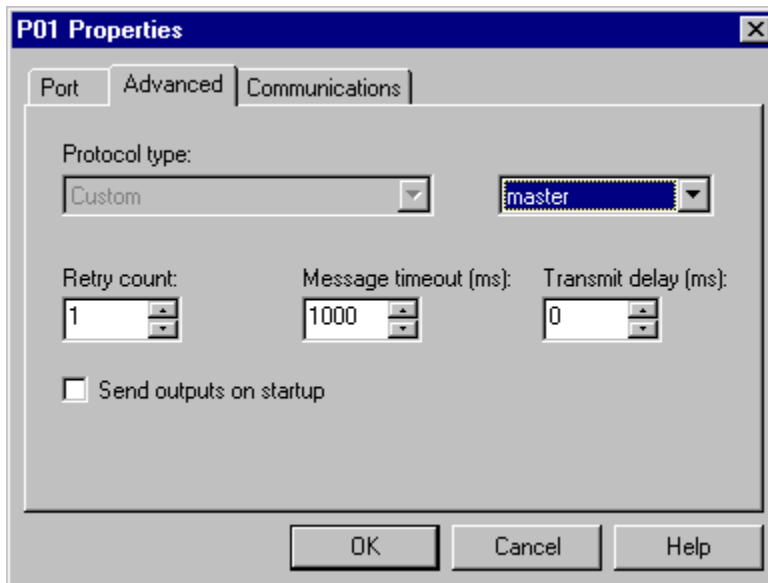
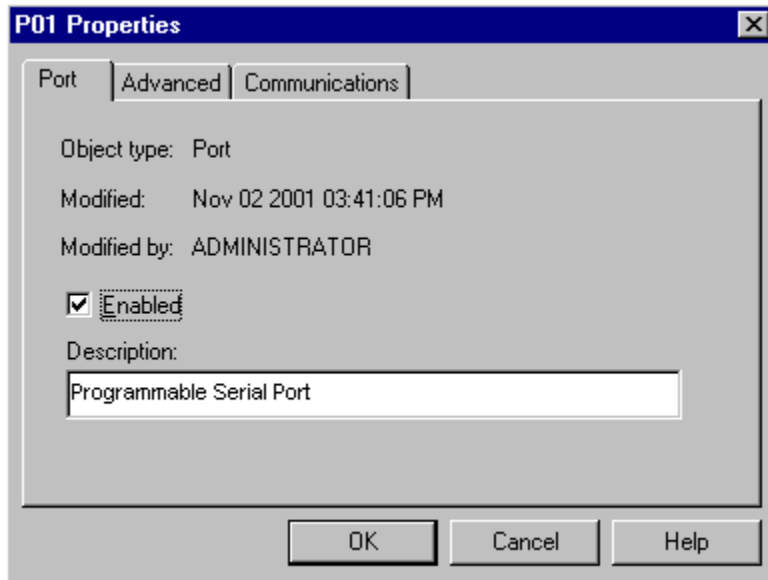

Configure the port as Master as shown above. Configure the communications parameters as shown below, making sure that these match the field device. If the PSIC is to be a Slave to another Enron Modbus master, use the drop-down list and select Slave.

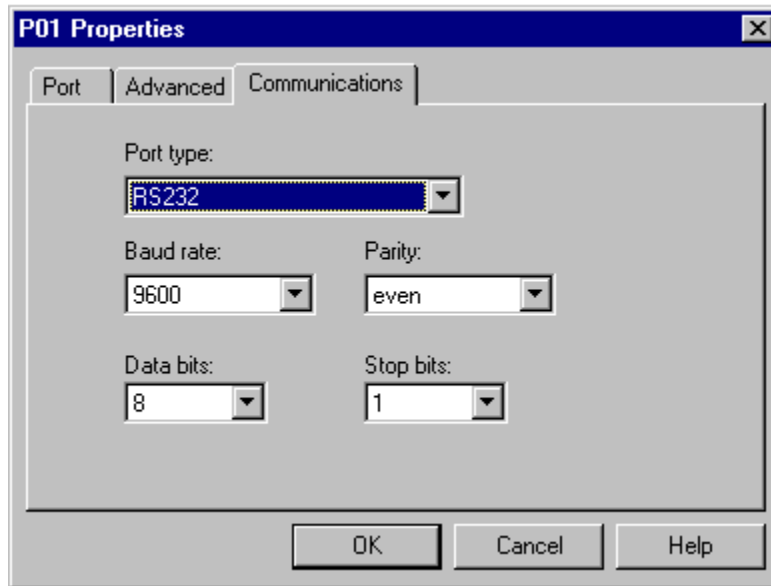

Click on OK to complete Port Configuration.

Step 3:

Add a device at address 1 under port P01. Right Mouse Click on Port P01 as shown below and select New Device.

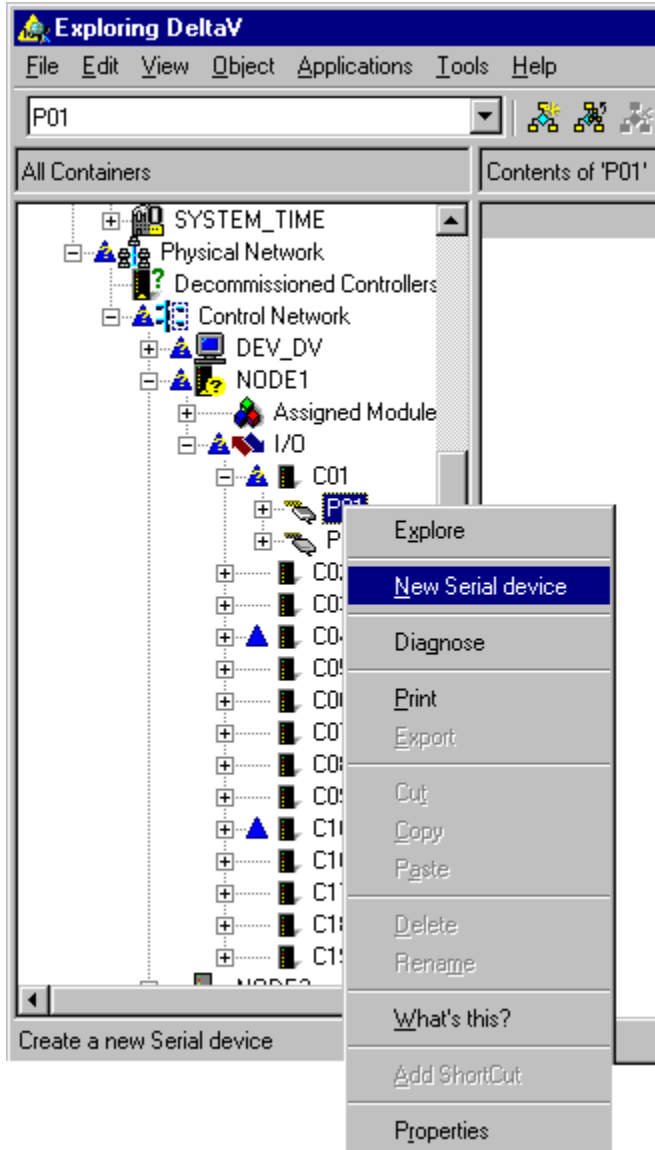

The following dialog will appear. Add description text and click OK.



A screenshot of a Windows-style dialog box titled "Properties". The dialog box has a blue title bar with a question mark icon and a close button. The main area is light gray and contains the following fields and buttons:

- Object type: Serial I/O Device
- Modified:
- Modified by:
- Description: Enron Modbus device
- Device Address: 1
- Buttons: OK and Cancel

Step 4:

Now we must create datasets under the device. The datasets will have different configuration parameters based on the type of Enron registers being accessed. First, Right Mouse Click on DEV01, and select New Dataset as shown below:

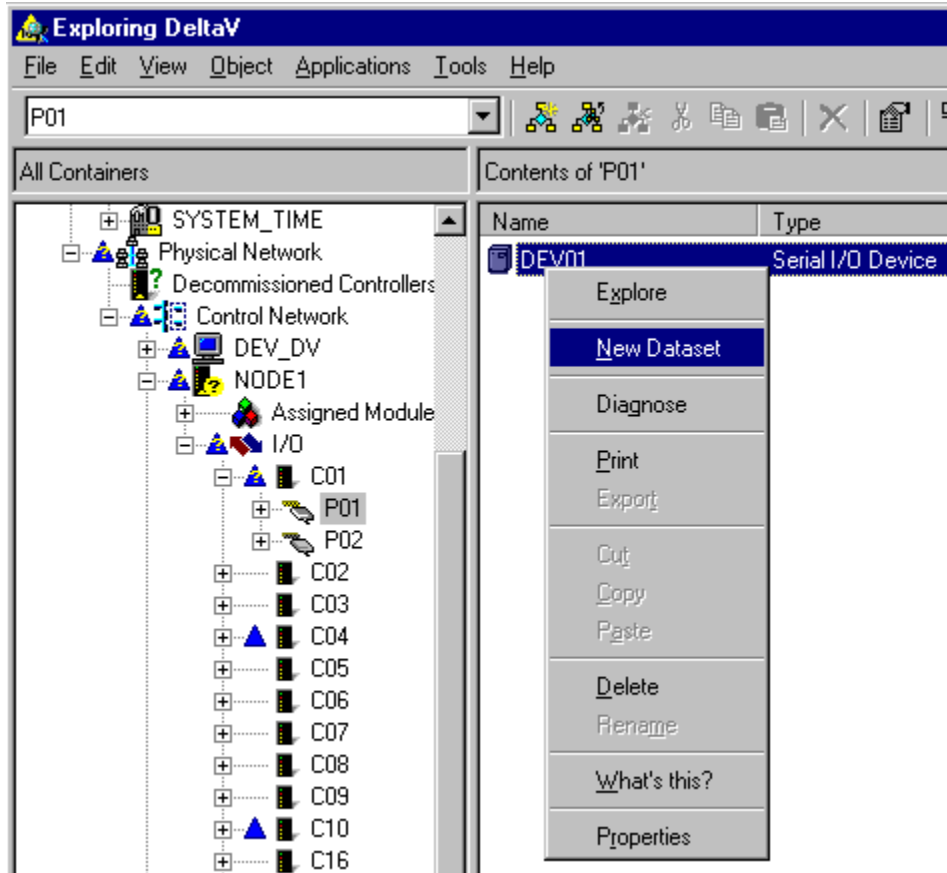

When New Dataset is selected, the following dialog will appear. We will create 2 input datasets. Configure the parameters as given in Table 5 and shown in the following dialogs:

Table 5

Device#	Dataset#	DeltaV Data Type	Device Data Type	Start Address	Number of Values	Special Data 1
1	1	Boolean	0	1000	10	0
1	2	Floating Point	1	7000	10	1



Dataset 1 dialogs:

The screenshot shows the 'Create dataset' dialog box with the 'General' tab selected. The dialog has a title bar with a close button. Below the title bar are four tabs: 'General', 'DeltaV', 'PLC', and 'Special data'. The 'General' tab contains the following fields and controls:

- Object type: (empty text field)
- Modified: (empty text field)
- Modified by: (empty text field)
- Description: (empty text area)
- Data direction: (dropdown menu showing 'input')
- Output mode: (text field showing '0')
- Output read back?: (checkbox, currently unchecked)

At the bottom of the dialog are three buttons: 'OK', 'Cancel', and 'Help'.

The screenshot shows the 'Create dataset' dialog box with the 'DeltaV' tab selected. The dialog has the same title bar and tabs as the previous screenshot. The 'DeltaV' tab contains the following fields and controls:

- DeltaV data type: (dropdown menu showing 'Boolean with status')
- Dataset Tag: (text field showing 'NODE101010101') with a 'Browse...' button to its right.

At the bottom of the dialog are three buttons: 'OK', 'Cancel', and 'Help'.



The screenshot shows the 'Create dataset' dialog box with the 'General' tab selected. The 'Device data type' field contains the value '0'. The 'Data start address' field contains '1000'. The 'Number of values' field is a spinner box set to '10'. At the bottom are 'OK', 'Cancel', and 'Help' buttons.

The screenshot shows the 'Create dataset' dialog box with the 'Special data' tab selected. It features five input fields labeled 'Special data 1' through 'Special data 5', each containing the value '0'. At the bottom are 'OK', 'Cancel', and 'Help' buttons.

Dataset 2 dialogs:

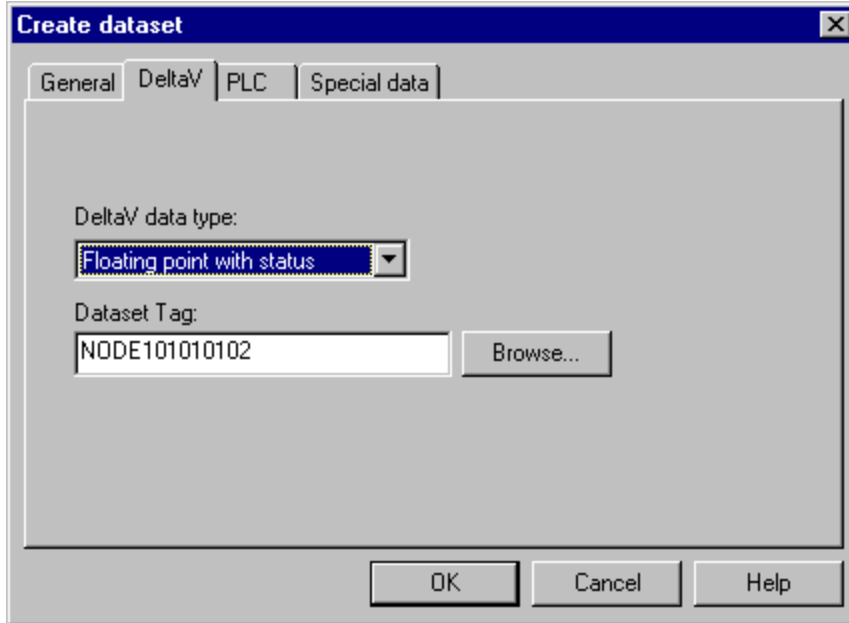

The screenshot shows a 'Create dataset' dialog box with the 'DeltaV' tab selected. The 'General' tab is also visible. The 'DeltaV data type' dropdown menu is set to 'Floating point with status'. The 'Dataset Tag' text box contains 'NODE101010102' and has a 'Browse...' button next to it. At the bottom, there are 'OK', 'Cancel', and 'Help' buttons.

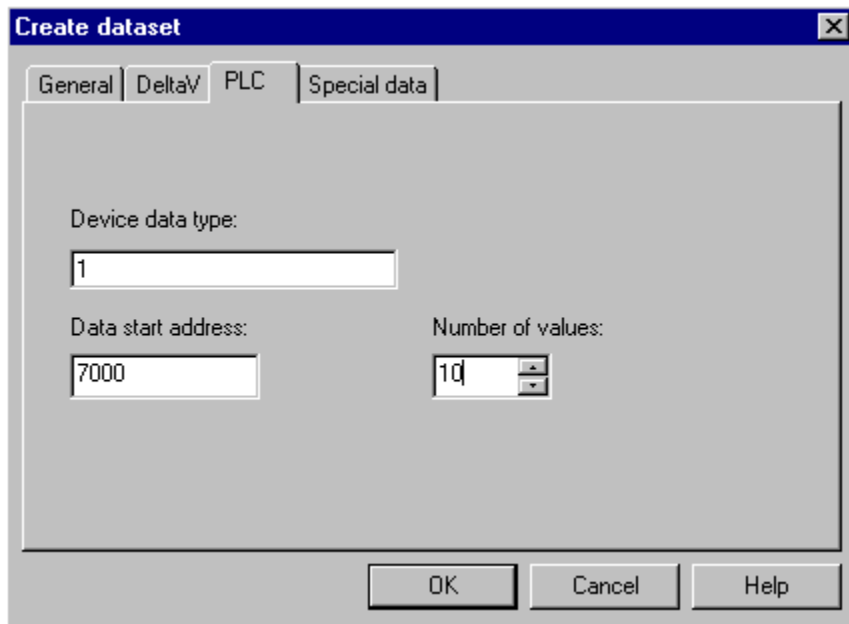

The screenshot shows the same 'Create dataset' dialog box, but with the 'PLC' tab selected. The 'Device data type' text box contains '1'. The 'Data start address' text box contains '7000'. The 'Number of values' spinner box is set to '10'. At the bottom, there are 'OK', 'Cancel', and 'Help' buttons.



Create dataset [X]

General | DeltaV | PLC | **Special data**

Special data 1	<input type="text" value="1"/>
Special data 2	<input type="text" value="0"/>
Special data 3	<input type="text" value="0"/>
Special data 4	<input type="text" value="0"/>
Special data 5	<input type="text" value="0"/>

OK Cancel Help

Step 5:

In this step, we will create 2 output datasets under DEV01. Configure the dataset parameters as shown in Table 6 and dialogs below:

Table 6

Device#	Dataset#	DeltaV Data Type	Device Data Type	Start Address	Number of Values	Special Data 1
1	3	Boolean	0	1020	20	0
1	4	Floating Point	1	7050	10	1

Dataset 3 dialogs:

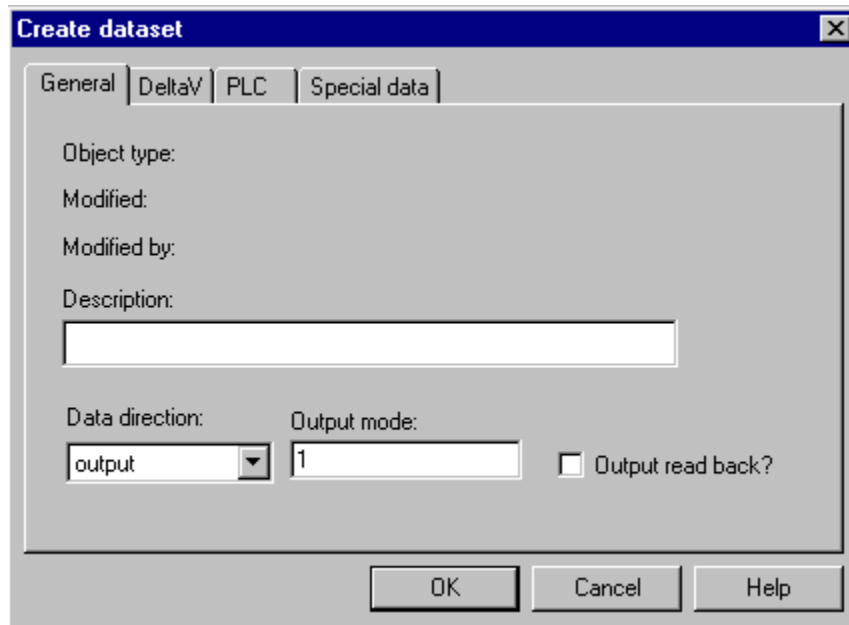

Dataset 3 has Output mode as 1, indicating single value writes. If a value changes, only that value will be written out.



Create dataset [X]

General | **DeltaV** | PLC | Special data

DeltaV data type:

Dataset Tag:

Create dataset [X]

General | DeltaV | **PLC** | Special data

Device data type:

Data start address: Number of values:

Dataset 2 dialogs:

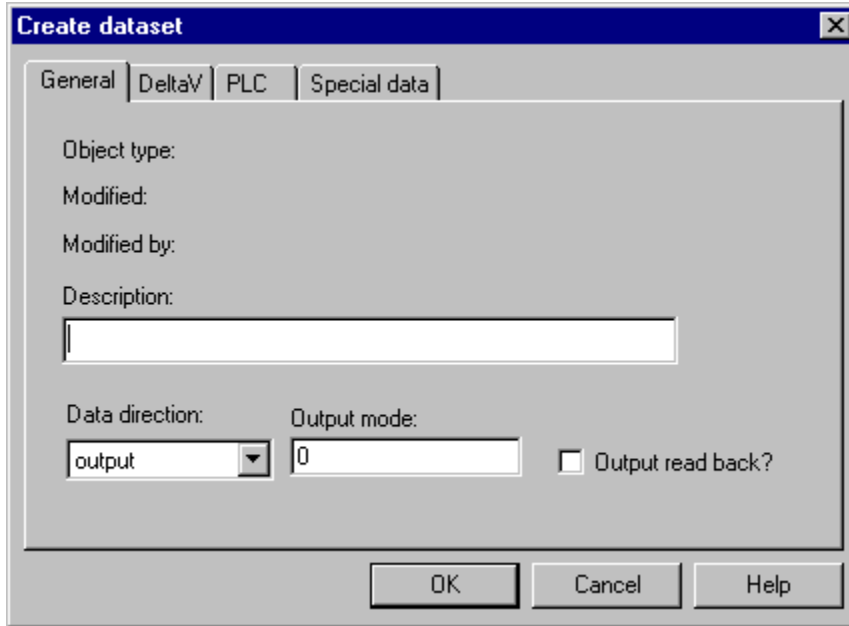

Dataset 4 has Output mode as 0, indicating block writes. When any value in the dataset changes, the entire dataset will be written out.

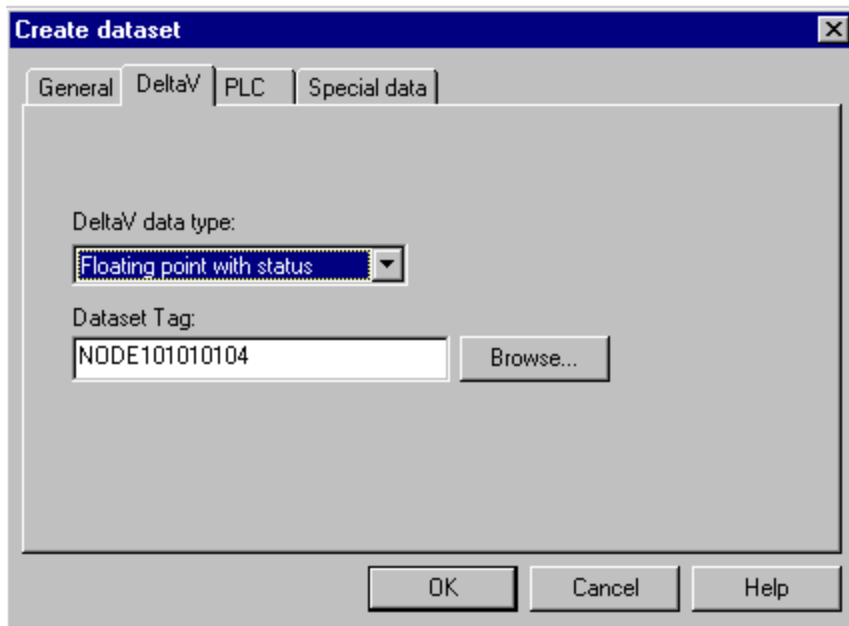

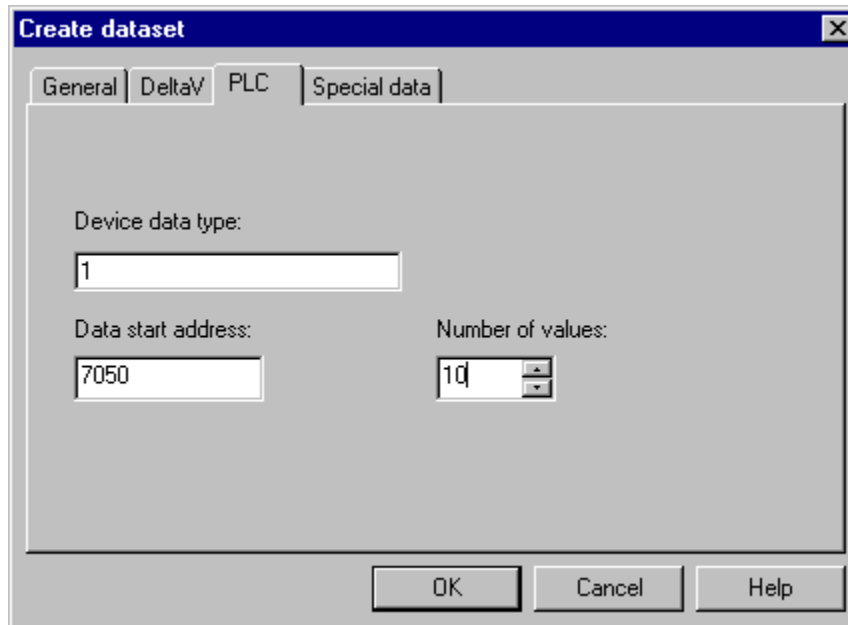

This completes the configuration procedure.