



M Y N A HSM

**Siemens 3964R
Programmable Serial Interface Card
Series 2**

USER MANUAL

Rev. P1.10

December 10, 2003

DeltaV is a trademark of Emerson Process Management, Inc © Emerson Process Management, Inc. 1998, 1999.
All rights reserved.

Printed in the U.S.A.

While this information is presented in good faith and believed to be accurate, Mynah Technologies does not guarantee satisfactory results from reliance upon such information. *Nothing contained herein is to be construed as a warranty or guarantee, express or implied, regarding the performance, merchantability, fitness or any other matter with respect to the products*, nor as a recommendation to use any product or process in conflict with any patent. Mynah Technologies reserves the right, without notice, to alter or improve the designs or specifications of the products described herein.



1 INTRODUCTION

1.1 Scope

This document is the User Manual for the Siemens 3964R serial communication driver firmware for the Emerson Process Management (EPM) DeltaV Control System; it provides information required to install, configure, and maintain the driver firmware on the DeltaV Programmable Serial Interface Card (PSIC). The reader should be familiar with EPM's DeltaV PSIC and connected Siemens field devices (supporting the 3964R protocol).

The section *Document Format* briefly describes the contents of each section of this manual. *System Specifications* outlines hardware and software requirements for the Siemens 3964R Driver (P1.10) firmware.

1.2 Document Format

This document is organized as follows:

Introduction	Describes the scope and purpose of this document.
Theory of Operation	Provides a general functional overview of the Siemens 3964R Driver.
Downloading Firmware	Describes downloading procedures for the Siemens 3964R Driver firmware on to the DeltaV PSIC.
Configuration Information	Describes procedures and guidelines for configuring the DeltaV PSIC.
Operational Check	Provides tips and assistance to ensure PSIC is properly setup and configured.
DeltaV–Field Device Electrical Interface	Describes the electrical interface between DeltaV and the Field Device. Also describes the cable pin assignments for RS-232 and RS-422/485 communications.
Technical Support	Describes who to call if you need assistance.



1.3 System Specifications

The following table lists the minimum system requirements for the Siemens 3964R Driver:

Table 1: System Specifications

Firmware	Siemens 3964R Driver Firmware (P1.10)
Protocol Compatibility	Siemens 3964R Protocol, as documented in Simatic S5 CP 521 SI Communication Bulletin
Software Requirements	DeltaV System Software (Release 6.3 or later) installed on a hardware-appropriate Windows NT workstation configured as a ProfessionalPlus for DeltaV Serial Interface Port License (VE4102)
Minimum DeltaV Hardware Requirements	DeltaV Serial Module, Series 2 only DeltaV M3, M5, M5+ or MD Controller, Power Supply and 8 wide controller carrier



2 THEORY OF OPERATION

As part of the serial interface port license, a standard Modbus protocol is installed on the DeltaV PSIC prior to customization. The PSIC needs to be flash upgraded from the Modbus protocol to the Siemens 3964R firmware before operation.

The Programmable Serial Interface Card (PSIC) supports RS-232, RS-422/RS-485 Half Duplex and RS-422/RS-485 Full Duplex communications with Siemens PLC's. The electrical connection and communication settings must be configured properly to ensure accurate communication between the PSIC and Siemens PLC's. These are described in Section 4.1.

The primary functions of the driver are listed below:

- Performs data and message handling between DeltaV and Siemens PLC's.
- This driver runs in Master mode only. In this mode, the driver sends read/write commands to the Siemens PLC, checks validity of responses received, and updates the corresponding DeltaV PSIC registers. PLC register types available for read and write are as follows:

Each PSIC, when loaded with the Siemens 3964R Driver, is capable of communicating with Siemens PLC's over one or both of its two ports, depending upon your application.



3 Downloading the firmware

The DeltaV Controller upgrade utility is used to flash the Serial Card with the distributed firmware. The firmware distribution software comprises 15 files, distributed on a CD. These files must be copied to the DeltaV directory on your ProPlus Workstation. Note that you will have to create the **\Siemens 3964R S2** subdirectory. The path is:

\DeltaV\ctl\ProgSerial\Siemens 3964R S2

The following shows a completed copy operation:

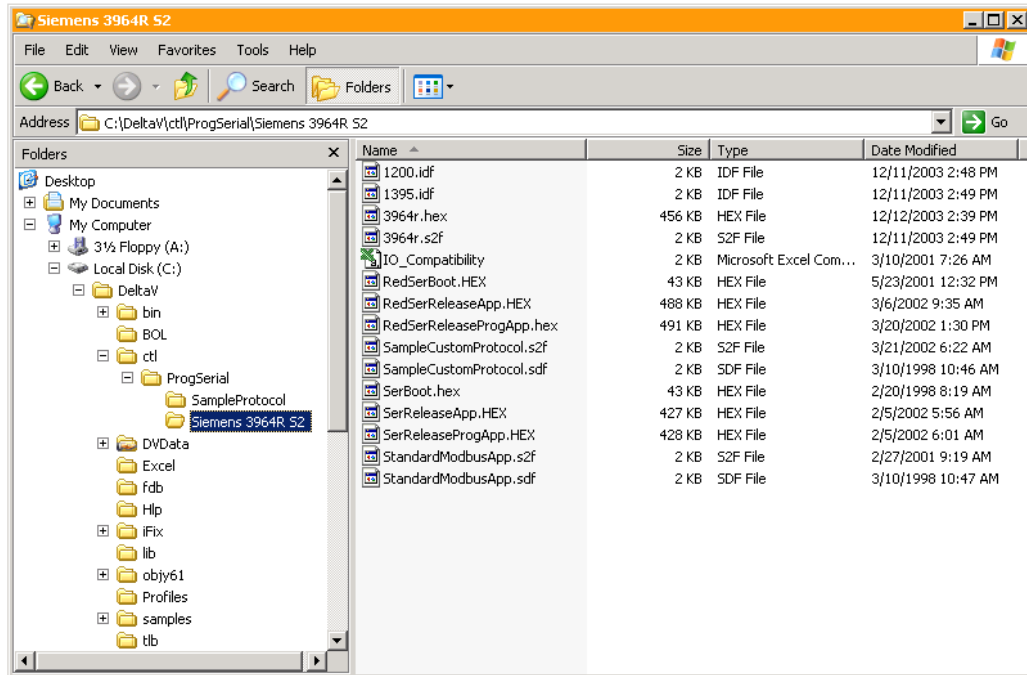

After copy completion, you are ready to program (or upgrade) the Programmable Serial Card with the supplied custom driver software. The steps are as follows:



1. Click on the Start button and select DeltaV-> Installation-> Controller Upgrade Utility as shown below:

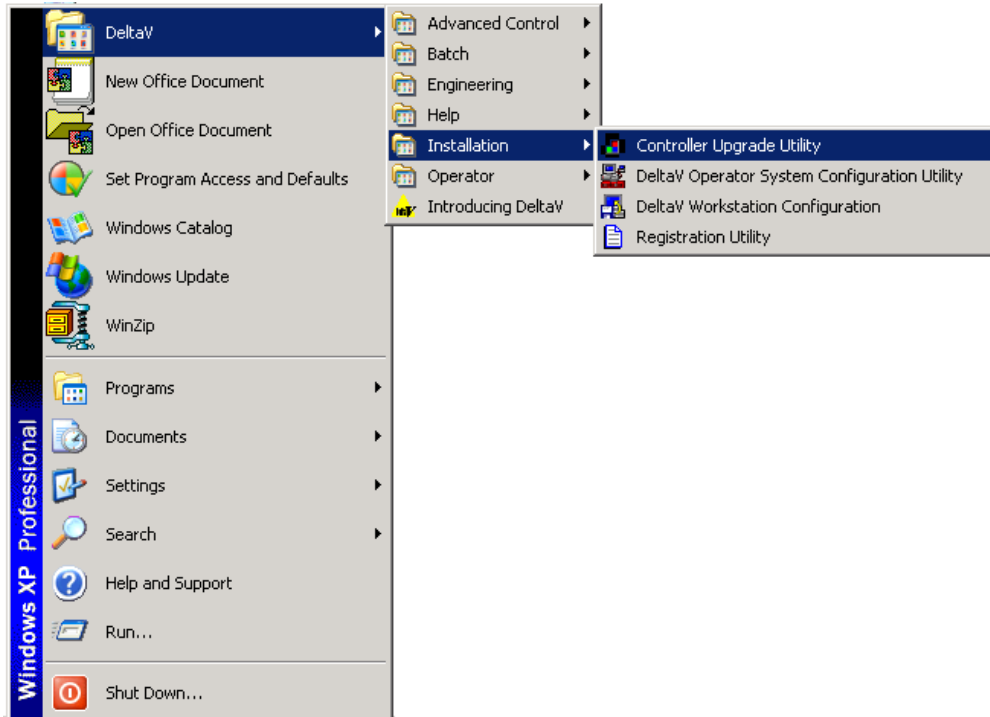

The following dialog will appear:

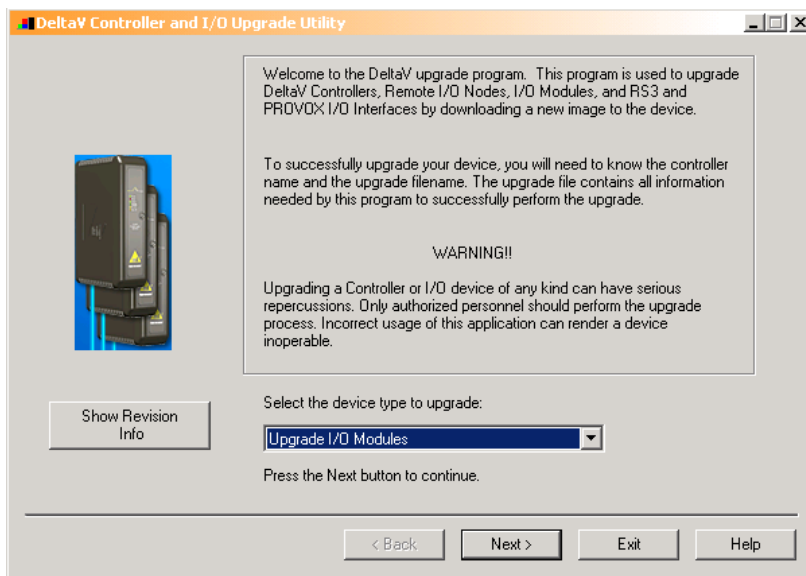

2. Select the Upgrade I/O Modules option as shown above, and then click Next.

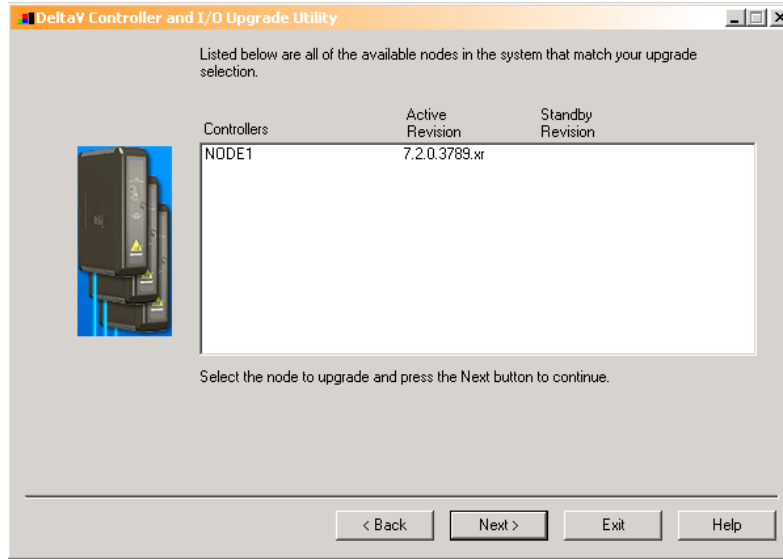

3. The above dialog will appear, listing all the available Controllers in your network.
4. From this dialog, select the appropriate Controller and then Click Next. The dialog with all configured I/O modules will appear as shown below. Your list will be different.

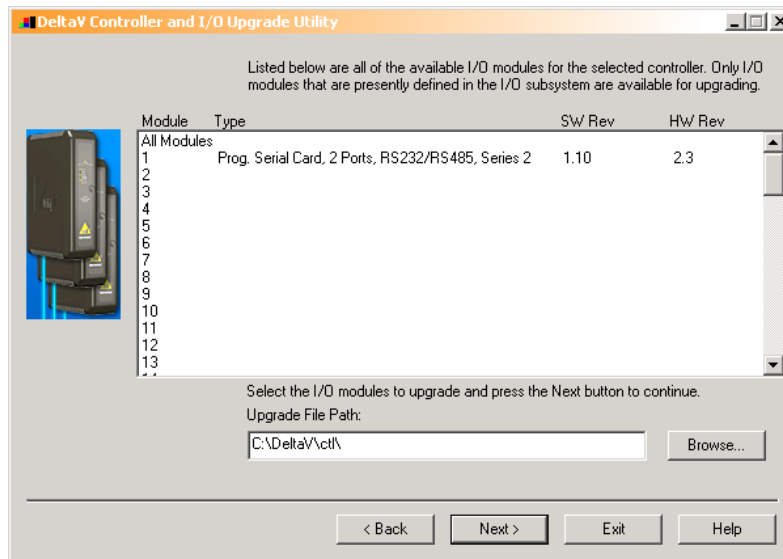

Note

The first time a standard Serial card is upgraded to the Siemens 3964R firmware, Steps 5 and 6 must be performed. When upgrading an existing Programmable Serial Card, skip Steps 5 and 6, and go to Step 7.



5. Click the Browse button and select the DeltaV path as shown below. Note that the disk drive could be C or D. After selecting the folder, you will be back in the dialog showing I/O Modules.

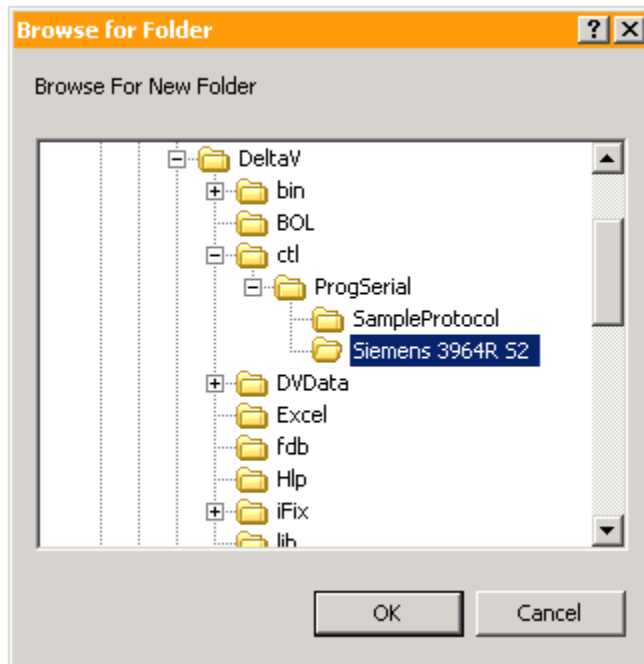

6. Select the Serial module and then click Next. Go to Step 9.

7. If you are upgrading an existing Programmable Serial Card, the dialog will be as shown below. From this dialog, select the Programmable Serial Card I/O Module in the list.

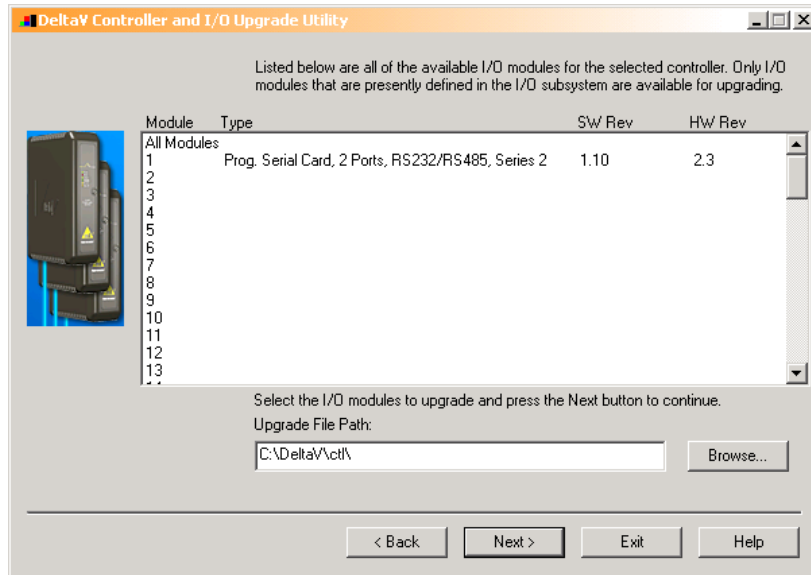

For example, we will select I/O Module 1. This will give you a dialog, from which you will select the file path to where the driver software is located. This path will be:

\\DeltaVctl\ProgSerial\Siemens 3964R S2

Once you are in the specified directory, you will need to select the following file:

3964r.S2F

This is shown in the following dialog.

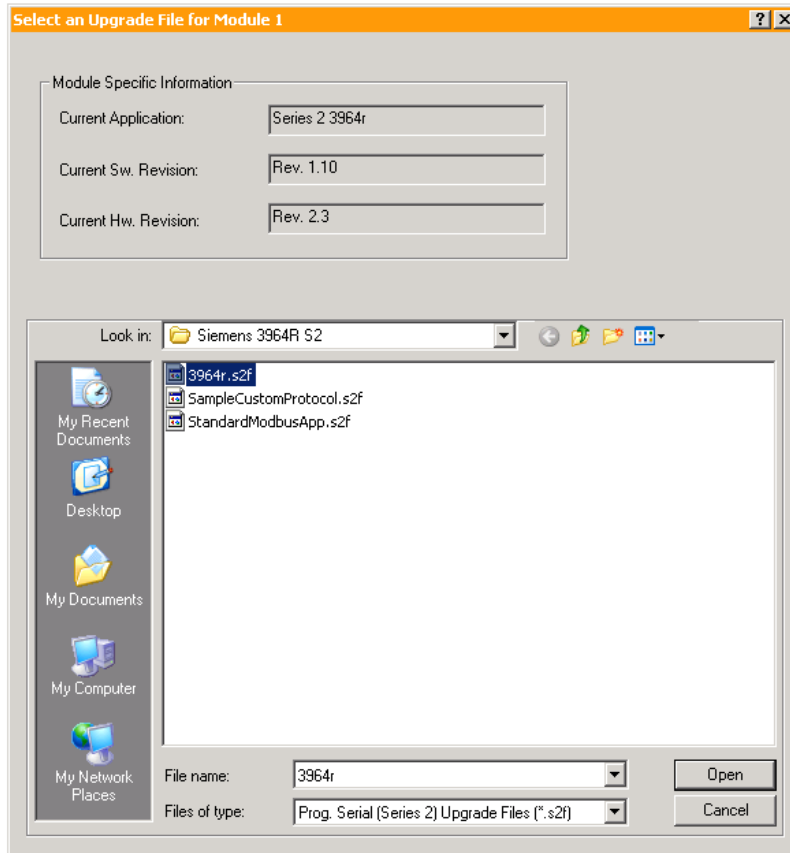

8. After selecting the .S2F file, Click on Open. This dialog will close and you will be back to the following:

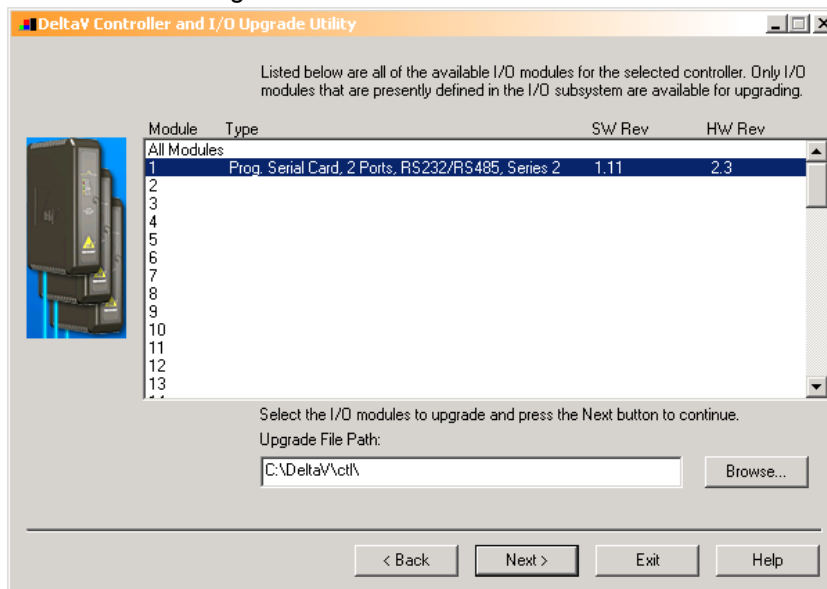



9. In this dialog, Click Next again. You will get the following dialog, confirming the Controller and I/O Module to program.

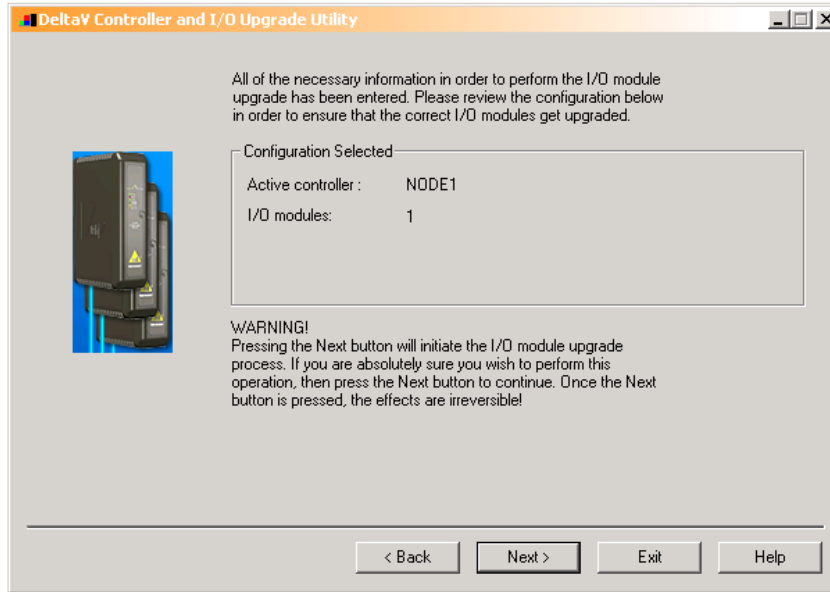

10. Click Next and the I/O Module upgrade process will begin. After completion, you will receive the following dialog, indicating success.

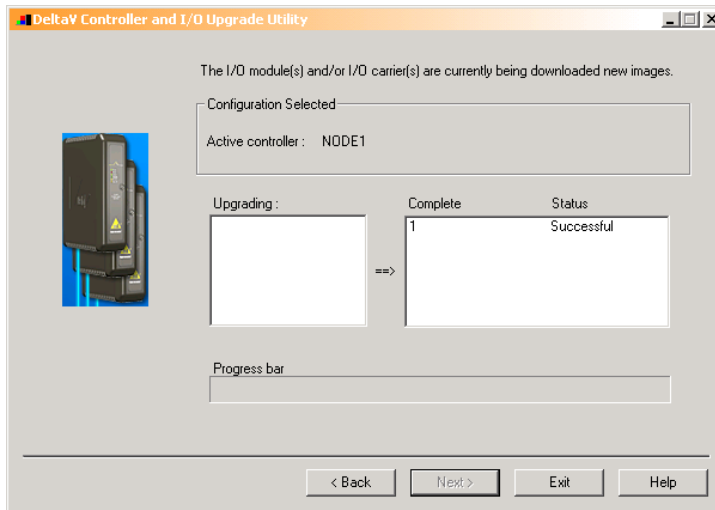

11. This completes the I/O Module upgrade process.



4 CONFIGURATION INFORMATION

This section describes the steps necessary to configure the DeltaV PSIC to obtain proper communication.

Each Serial Card in the I/O subsystem contains two channels or ports. Each port will be enabled or disabled individually and each port will contain some port specific configuration parameters. Port configuration comprises RS-232 or RS-422/485, baud rate, parity, byte size, and stop bits used. All selected parameters must match the connected field device(s).

The DeltaV Explorer view of a configuration containing a PSIC will be as follows, where C01 has a card type of Programmable Serial Card, P01 and P02 are the ports on the card, DEVXX are the field devices attached to the ports and DSXX are configured datasets under each device. You can have one or more field devices (each with a unique address) under each port. The device address (under DEVXX) is used in communications, and it should match the PLC Address.

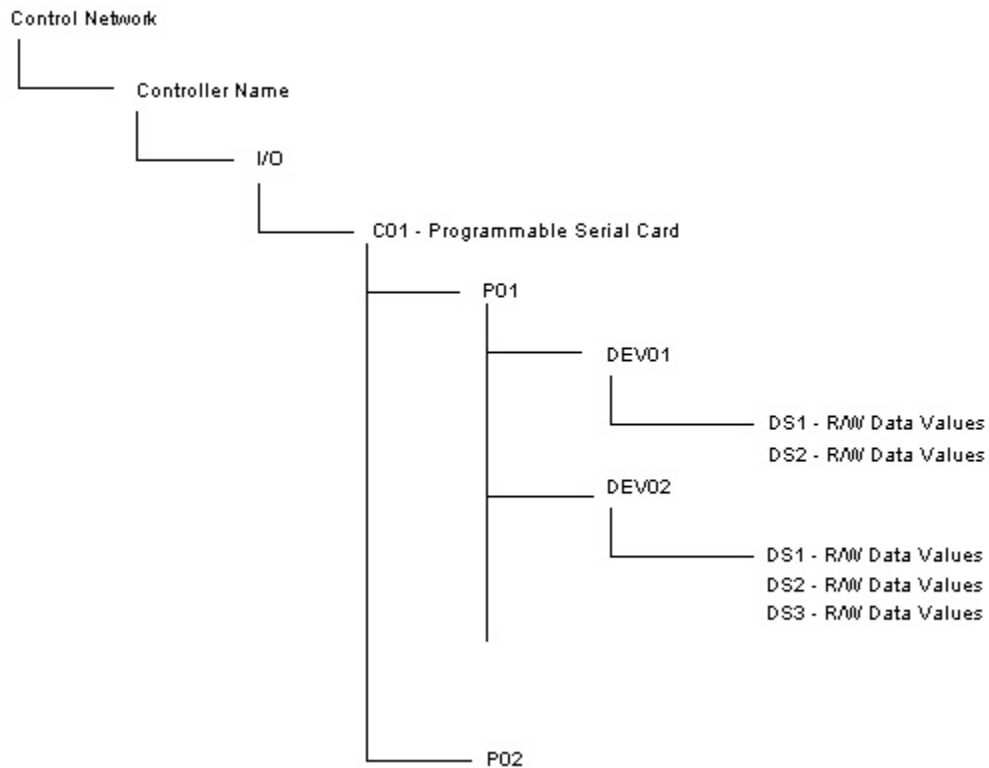

A total of 16 datasets can be configured under each port. The datasets are divided over the configured devices. A dataset represents register data read from the PLC, or written to a PLC. Output datasets can also be configured to read back.



4.1 Port Configuration

First, enable the port. Then click on the Advanced Tab and select Master. Specify the retry count, message timeout value in milliseconds, and message delay time. In most cases, you can leave these at their default values. Next, click on the Communications Tab and specify the Port type. The Port type will be RS-232 or RS-422/485. Lastly, select the Baud rate, Parity, Data bits and Stop bits parameters; these must match the PLC settings. Typically for PLC communications, these are 9600, Even parity, 8 bits and 1 stop bit.

4.2 Device Configuration

Specify devices, one for each PLC. The device address must match the PLC address.

4.3 Dataset Configuration

Datasets contain the field values read from a PLC or DeltaV values being written to a PLC. Each dataset will read or write data of one type. This is described in Table 2 below.

4.3.1 Data Direction:

The Data Direction for dataset should be defined as Input or output. This parameter is available only under Master mode.

4.3.2 Output Mode:

Two output modes are available in the DeltaV PSIC: Block Output (0) and Single Value Output (1). In block mode, any register change in the dataset will trigger the entire dataset to be written to the PLC. In single value mode, only the changed register is written out.



4.3.3 DeltaV Data Type:

The type of Siemens 3964R register being mapped will determine the DeltaV Data Type. This is described in the following table:

Table 2: Siemens 3964R Register Types

Device Data Type	Siemens 3964R Register Type	DeltaV Data Type
0	Data Block	8-bit INT, 8-bit UINT, 16-bit INT, 16-bit UINT, 32-bit INT, 32-bit UINT, FLOAT
1	Extended Block	8-bit INT, 8-bit UINT, 16-bit INT, 16-bit UINT, 32-bit INT, 32-bit UINT, FLOAT
2	Counters	16-bit INT, 16-bit UINT
3	Timers	16-bit INT, 16-bit UINT
4	Flag Bytes	8-bit INT, 8-bit UINT
5	I/O Bytes	8-bit INT, 8-bit UINT
6	Extended I/O Bytes	8-bit INT, 8-bit UINT
7	Input Bytes	8-bit INT, 8-bit UINT
8	Output Bytes	8-bit INT, 8-bit UINT
9	Absolute Addresses	8-bit INT, 8-bit UINT, 16-bit INT, 16-bit UINT, 32-bit INT, 32-bit UINT, FLOAT
10	System Addresses	8-bit INT, 8-bit UINT, 16-bit INT, 16-bit UINT, 32-bit INT, 32-bit UINT, FLOAT

4.3.4 DeviceDataType

The DeviceDataType determines which Siemens 3964R command is being sent to the PLC. See Table 2 above.



4.3.5 Data Start Address and Number of Values

The Start Address for each dataset should be configured to match the Siemens PLC registers it reads or writes. Note that DeltaV uses 1-based addressing, and dataset registers are indexed starting with 1, the Start Address must be configured such that (Start Address + 1) is the first Siemens register being accessed. For example, to access Register 1 in the PLC, use Start Address of 0. The start address and number of values must match the valid address for each type of PLC register.

Table 3: Siemens 3964R Register Ranges

Device Data Type	Siemens 3964R Register Type	DB Address	DW Address
0	Data Block	0-255	0-255
1	Extended Block	0-255	0-255
2	Counters	N/A	0-255
3	Timers	N/A	0-255
4	Flag Bytes	N/A	0-254
5	I/O Bytes	N/A	0-254
6	Extended I/O Bytes	N/A	0-254
7	Input Bytes	N/A	0-126
8	Output Bytes	N/A	0-126
9	Absolute Addresses	N/A	0-65535
10	System Addresses	N/A	0-511

The maximum number of registers read or written for a specific dataset is 64. Note that registers are 2 bytes each.



4.3.6 Special Data 1-5

The Special Data 1 register is used to select Siemens communications parameters. The values are as below:

Table 4: Protocol Options

Special Data Number	Default Value	Description
1	0	Data Block number for Device Data Type 0 and 1. This number has the range 0-255.
2	0	Not Used
3	0	Not Used
4	0	Not Used
5	0	Registers are transmitted/received in High Byte, Low Byte order.
	1	Registers are transmitted/received in Low Byte, High Byte order.



5 Operational Check

5.1 Scope

The following sections provide some assistance to ensure the interface is working properly.

5.2 Verify Hardware and Software Version Number

The user can verify that the Radio Modem Modbus driver has been installed using the DeltaV Diagnostics tool. The Diagnostics tool will show the Hardware Revision No. (HwRev) and the Software Revision No. (SwRev).

To begin the DeltaV Diagnostic tool select Start-> DeltaV-> Operator-> Diagnostics. In the Diagnostics tool expand the Controller, I/O and then double click on the Programmable Serial Interface Card that has the driver installed.

The following information will be displayed:

:	:	:
HwRev	Hardware Revision	2.3 (or later)
SwRev	Software Revision	P1.10 (or later)

5.3 Verify Configuration

- Verify port configuration: The serial port must be enabled. User needs to make sure communication settings such as baud rate, parity, and number of data bits match the field device settings.
- Verify dataset configuration: The datasets configured must be as shown above.

5.4 Verify I/O Communication With Control Studio

User can create I/O modules in the control studio to verify correct values are read from the PSIC. For AI and DI data, the values should be changed in the field device and verified that the new data are correctly reported in DeltaV. Similarly, verify that the AO and DO data is being written correctly from DeltaV to the field device.

5.5 Using Diagnostics

- Verify PSIC communication: Select the PSIC on Diagnostics and press the right mouse button. Select Display Real -Time Statistics from the drop down menu. If the Programmable Serial Interface Card is functioning then the user will see the Valid Responses counter and the Async and/or Sync Transactions counters incrementing. There will not be any error counting up.
- Verify port statistics: Select the Port on the Programmable Serial Interface Card and press the right mouse button. Then select Display Port Statistics form the drop down menu. Verify that the port communications statistics are being displayed properly and are counting as expected for the protocol's functionality.



- Verify dataset values: Select a dataset and press the right mouse button. Select View Dataset Registers from the Drop down window. Verify that the dataset values are displayed as expected.

5.6 LED Indication

The Yellow LED for the port should be on solid when all communications on that port are valid. The Yellow LED should be blinking if there is some valid communications and some communications with errors on that port. The Yellow LED should be OFF if there are no valid communications on that port.



6 DeltaV–Field Device Electrical Interface

The electrical interface between DeltaV and field devices conforms to the RS-232 and RS-422/485 standards.

Each PSIC has 2 ports, which function independently. The distance between the serial card and the field device can be as much as 4000 feet, per the RS-422/485 standard. When using RS-232, the distance is limited to 50 feet. Section 6.1 shows the pin assignments for the PSIC serial terminal block.

6.1 Pin Assignments for DeltaV PSIC

RS-422 Standard

Terminal Number	Signal Description
1	Port 1 - Isolated Ground (GND)
2	Port 1 – Transmit Data (TxD+)
3	Unused
4	Port 1 – Transmit Data (TxD-)
5	Unused
6	Port 1 – Receive Data (RxD+)
7	Unused
8	Port 1 – Receive Data (RxD-)
9	Port 2 - Isolated Ground (GND)
10	Port 2 – Transmit Data (TxD+)
11	Unused
12	Port 2 – Transmit Data (TxD-)
13	Unused
14	Port 2 – Receive Data (RxD+)
15	Unused
16	Port 2 – Receive Data (RxD-)

For additional detail, please refer to DeltaV Books Online.



7 Technical Support

For technical support or to report a defect, please give MYNAH Technologies a call at (636) 681-1555. If a defect is discovered, please document it in as much detail as possible and then fax your report to us at (636) 681-1660.

For Product functionality questions, ask for the people in the following order:

1. Nobin William
2. Martin Berutti

For Commercial issues, ask for people in the following order:

1. Martin Berutti
2. Jane Wagner

For all other driver and related questions, ask for Nobin William.

You can also send us your questions via e-mail. Our address is:

support@mynah.com

Thank you for using DeltaV.