



M Y N A HSM

**Rice Lake Weigh Scale Application
Programmable Serial Interface Card**

USER MANUAL

Rev. P1.0

October, 2000

DeltaV is a trademark of Emerson Process Management, Inc © Emerson Process Management, Inc. 1998, 1999. All rights reserved.

Printed in the U.S.A.

While this information is presented in good faith and believed to be accurate Mynah Technologies does not guarantee satisfactory results from reliance upon such information. *Nothing contained herein is to be construed as a warranty or guarantee, express or implied, regarding the performance, merchantability, fitness or any other matter with respect to the products*, nor as a recommendation to use any product or process in conflict with any patent. Mynah Technologies reserves the right, without notice, to alter or improve the designs or specifications of the products described herein.



Driver Installation

The driver software comprises 4 files, distributed on a 3.5” diskette. These files must be copied to the DeltaV directory on your ProPlus Workstation. The path is:

\\DeltaV\ctl\ProgSerial\SampleProtocol

The following shows a completed copy operation:

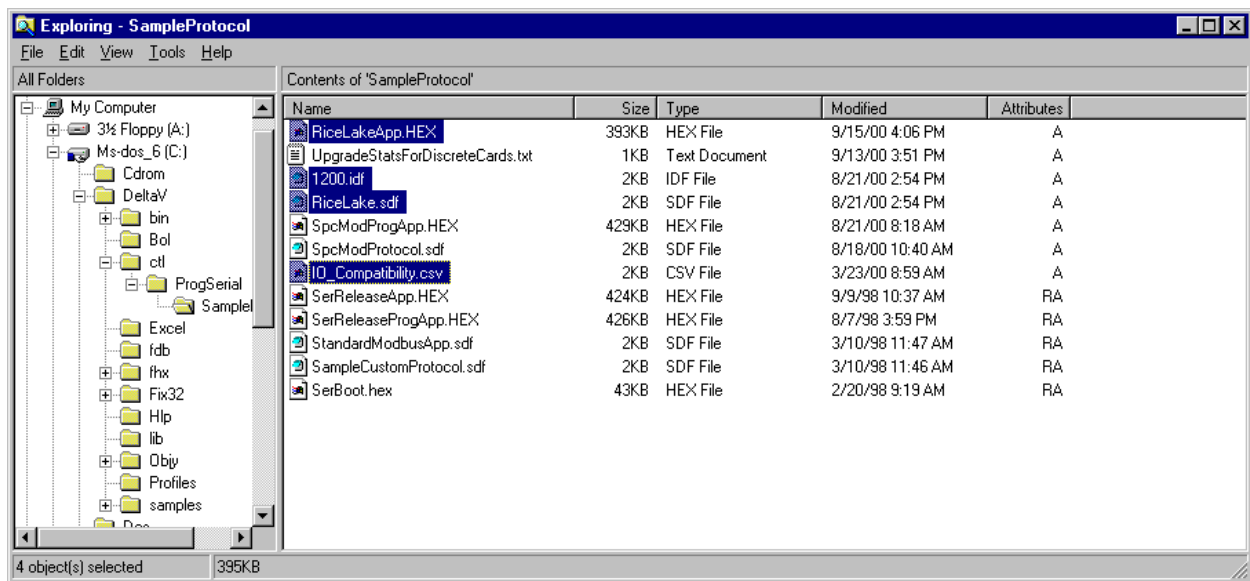



After copy completion, you are ready to program (or upgrade) the Programmable Serial Card with the supplied custom driver software. The steps are as follows:

1. Click on the Start button and select DeltaV, Installation, Controller Upgrade Utility as shown below.

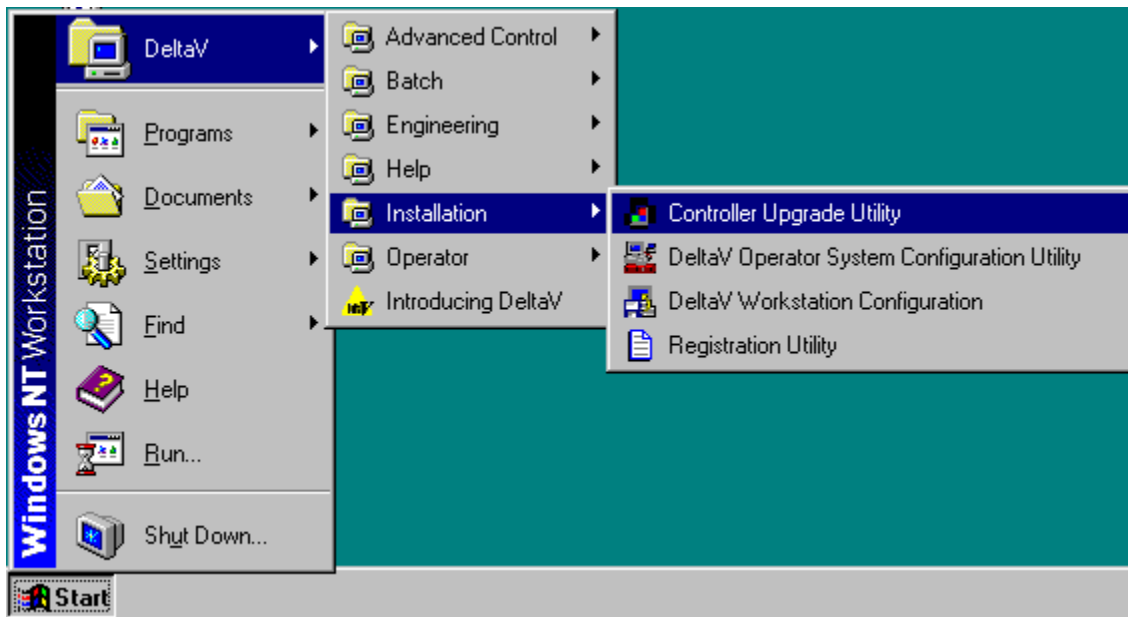



The following dialog will appear:

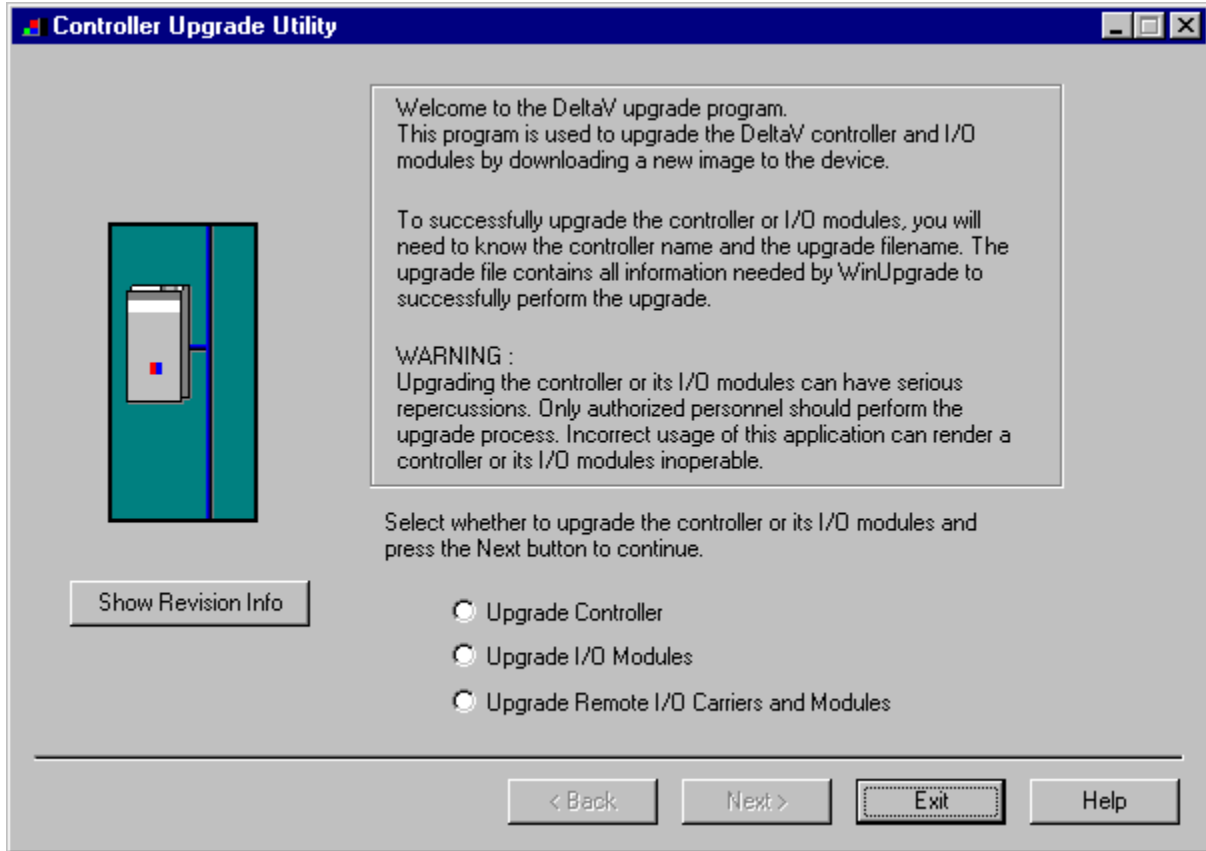

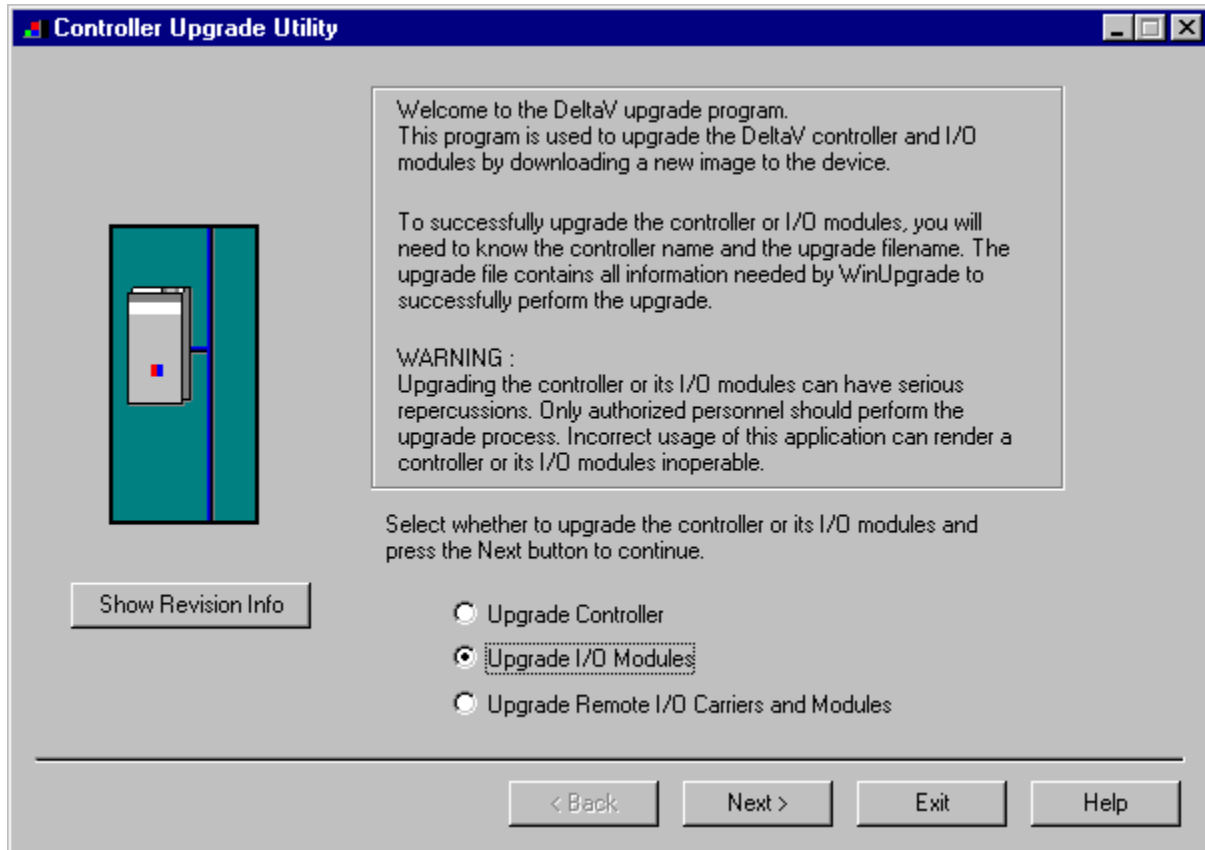

Click on the Upgrade I/O Modules radio button, and then click Next.

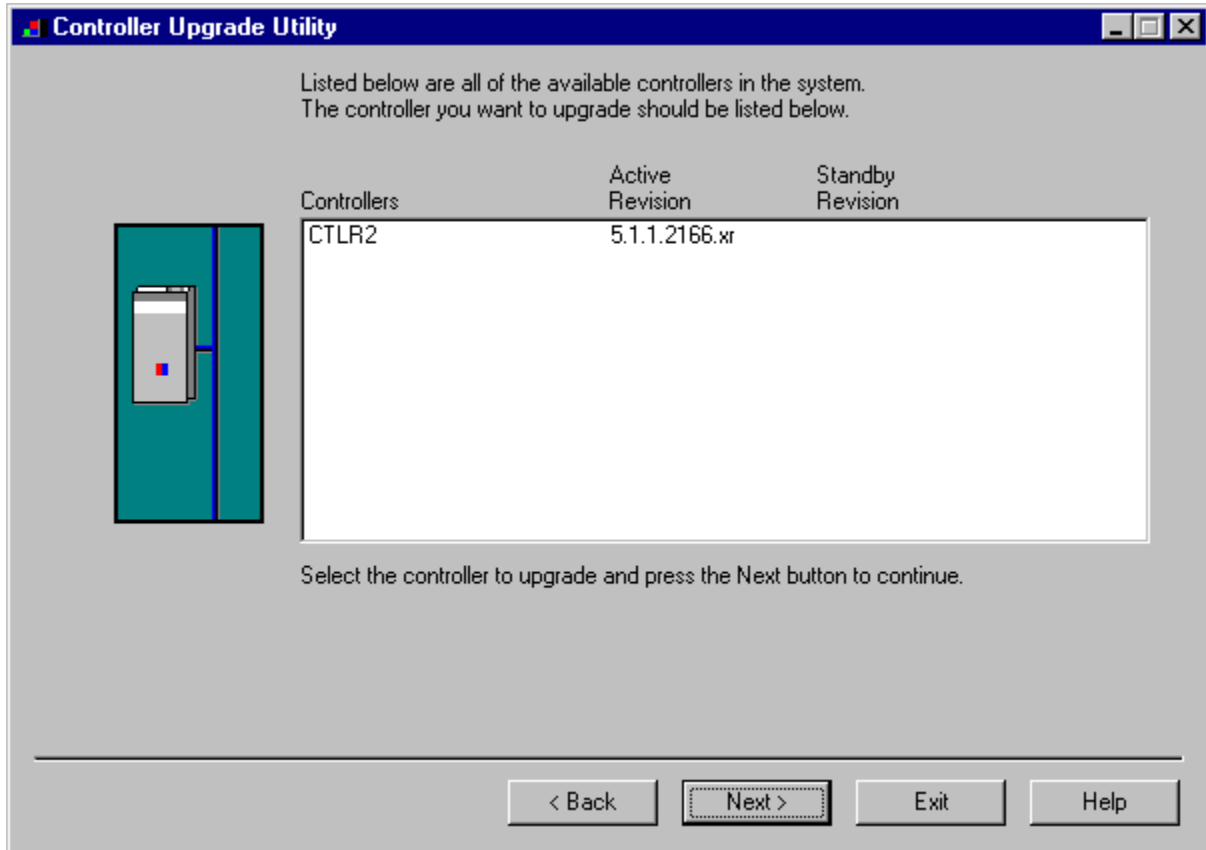

The above dialog will appear, listing all the available Controllers in your network. From this dialog, select the appropriate Controller and then Click Next as shown below.

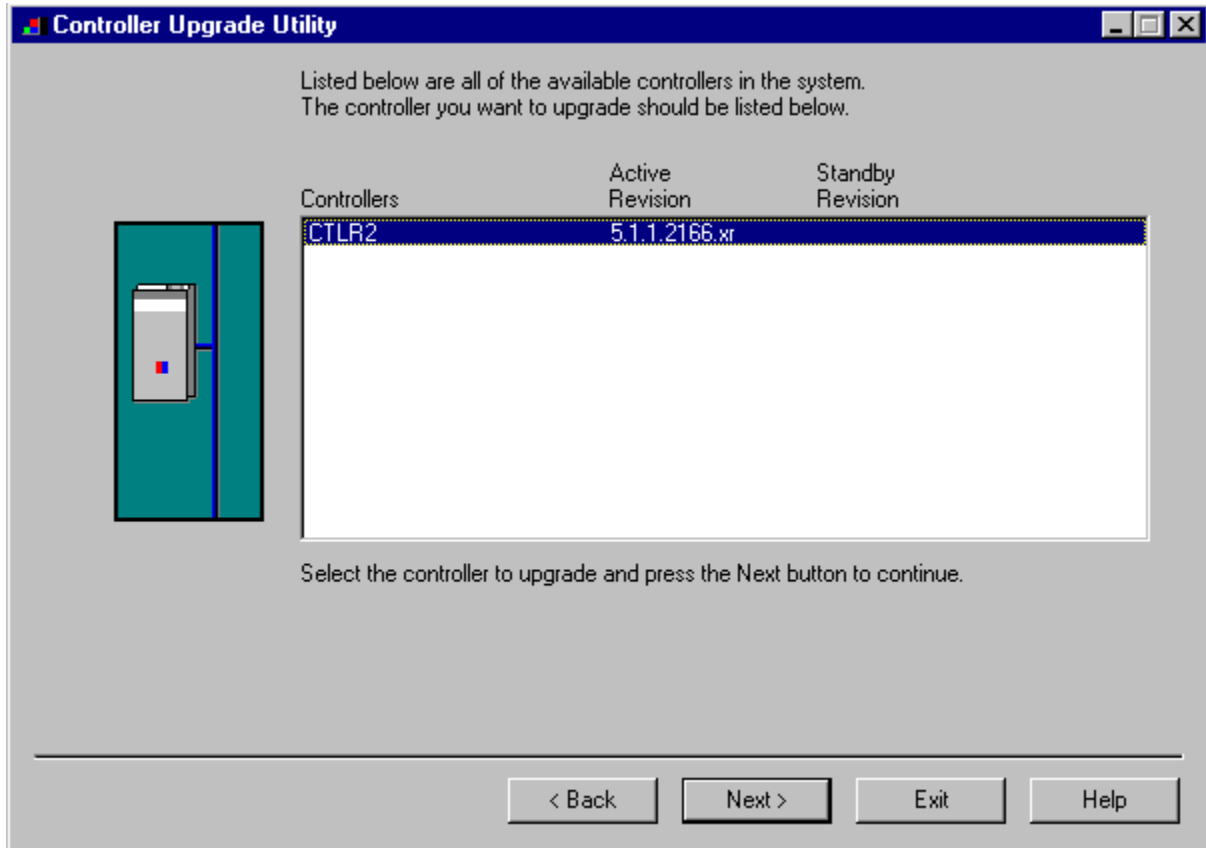

After you Click Next, the following dialog will appear, listing all the I/O modules in your selected Controller. The shown list of I/O modules is an example only. Your list will be different.

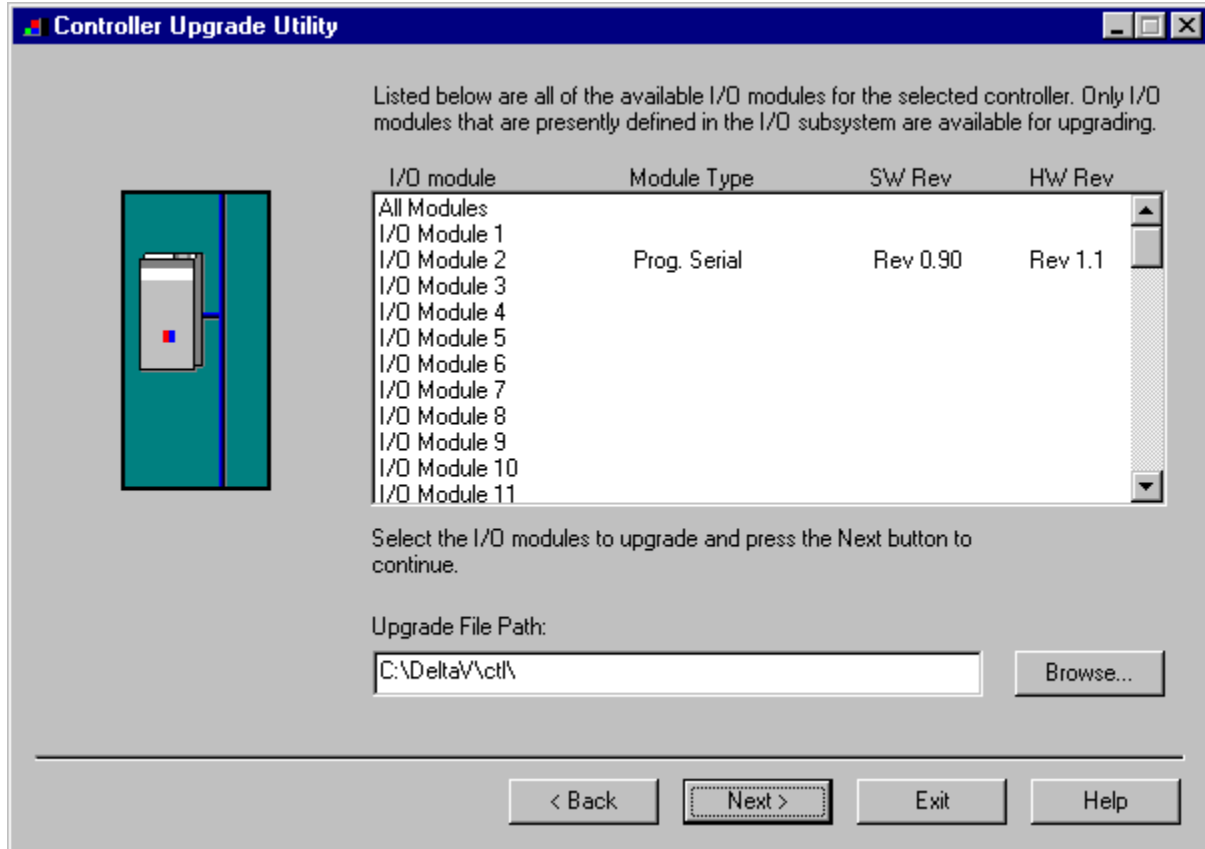

From this dialog, select the Programmable Serial Card I/O Module in the list. For example, we will select I/O Module 2. This will give you the following dialog, from which you will select the file path to where the driver software is located. This will be:

\\DeltaV\ctl\ProgSerial\SampleProtocol.

Once you are in the specified directory, you will need to select the following file:

RiceLake.SDF

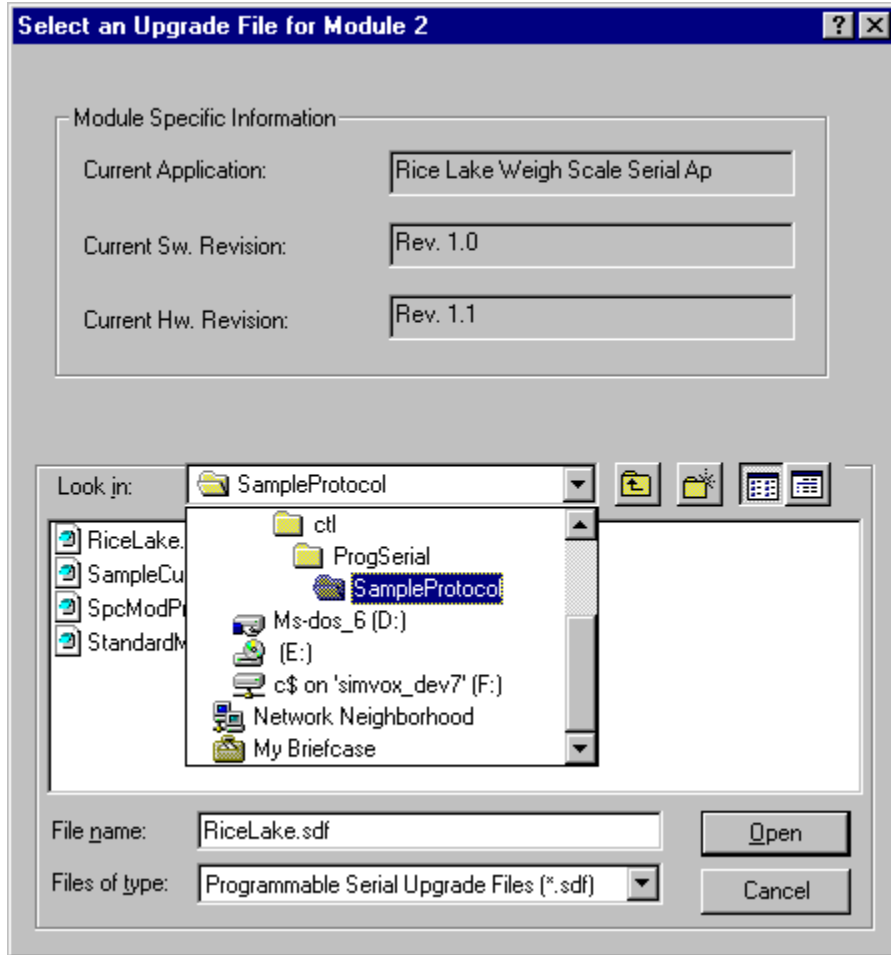

After selecting the .SDF file, Click on Open. This dialog will close and you will be back to the following:

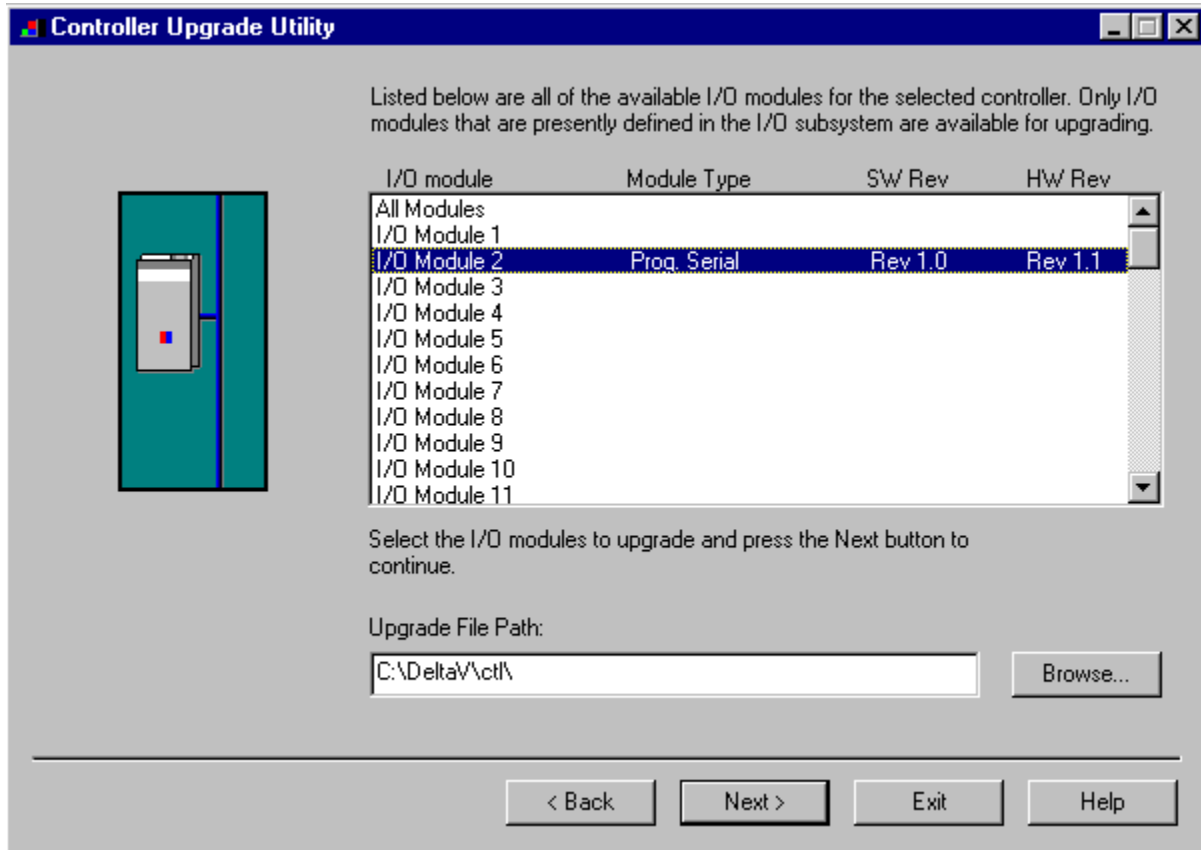

In this dialog, Click Next again. You will get the following dialog, confirming the Controller and I/O Module to program.

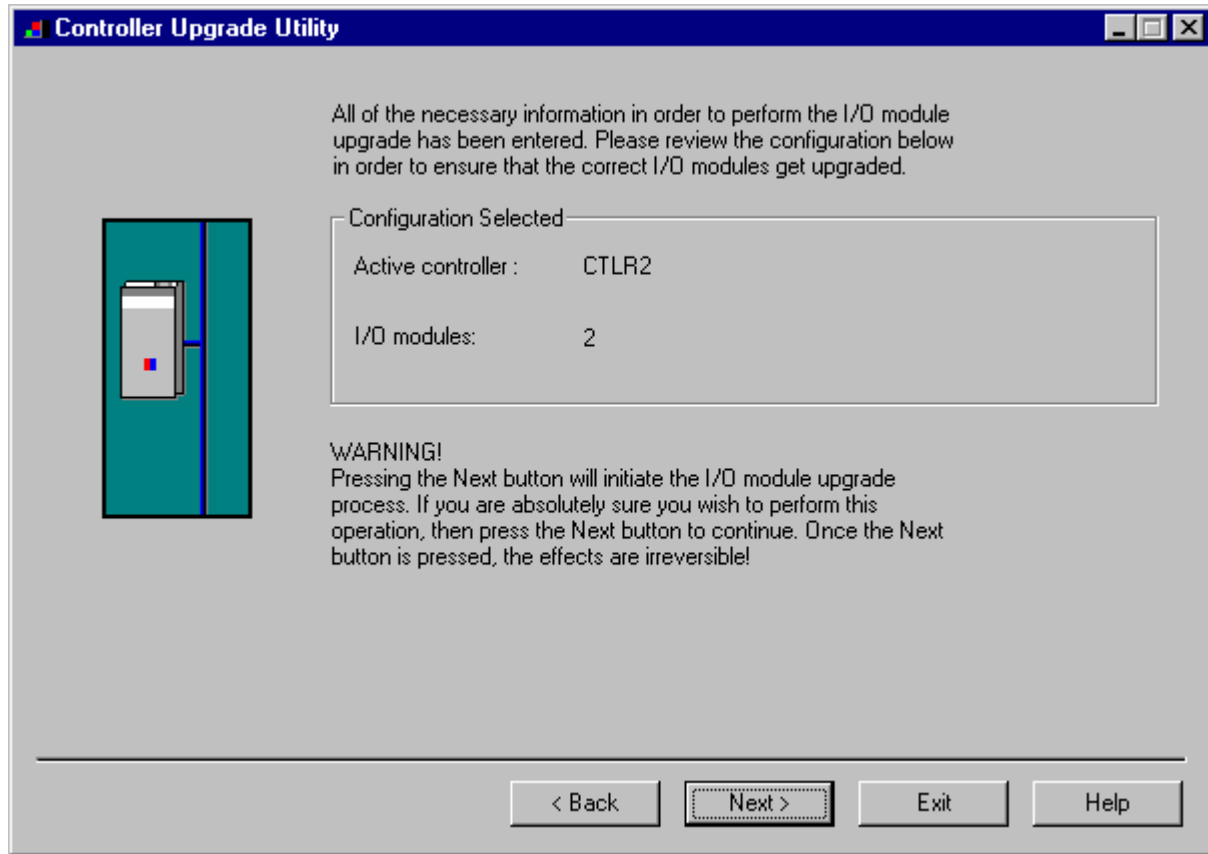

Click Next and the I/O Module upgrade process will begin. After completion, you will receive the following dialog, indicating success.

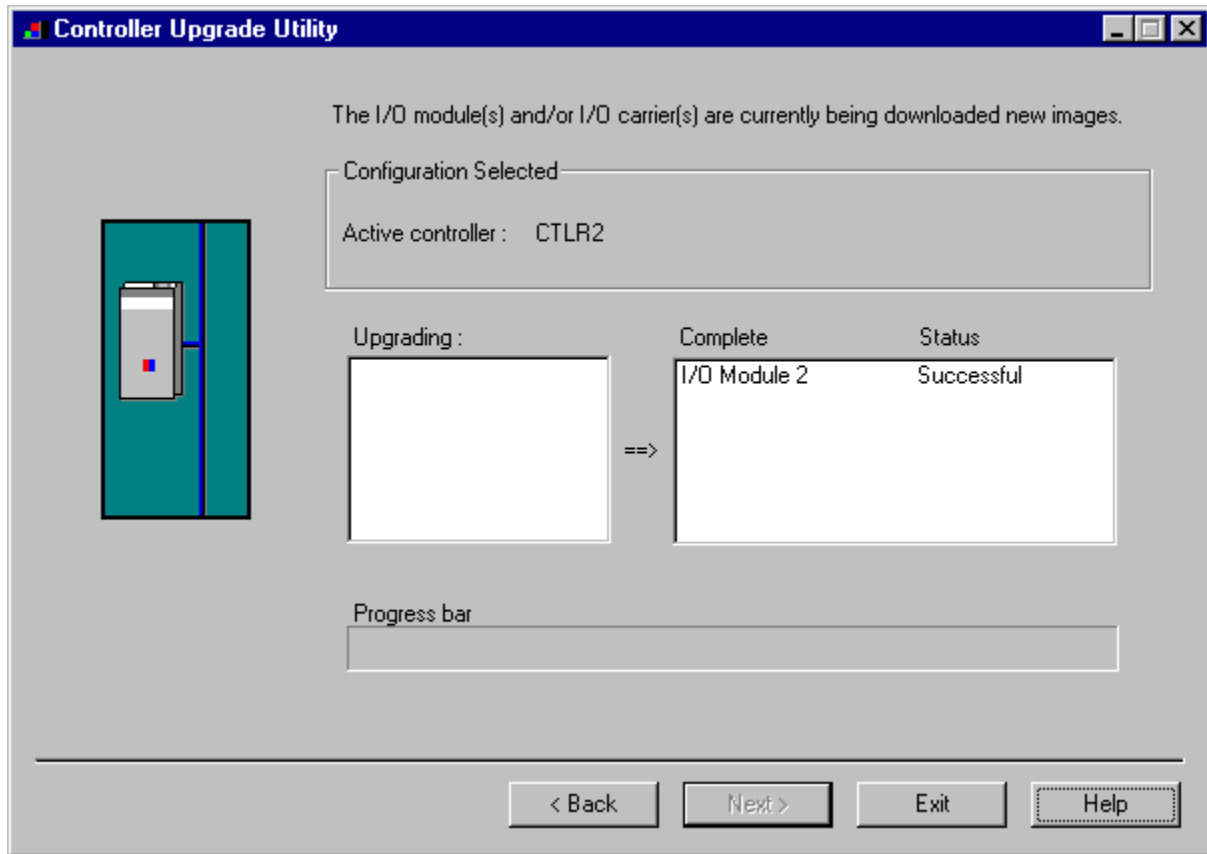

This completes the I/O Module upgrade process.



Serial Card Hookup – RS-232

The Programmable Serial Card supports RS-232 communications with field devices. The following is an RS-232 hookup, with 2 serial cards. Each serial card supports 2 weigh scales, 1 per port. The distance between the serial card and the weigh scale must not exceed 50 feet, per the RS-232 standard.

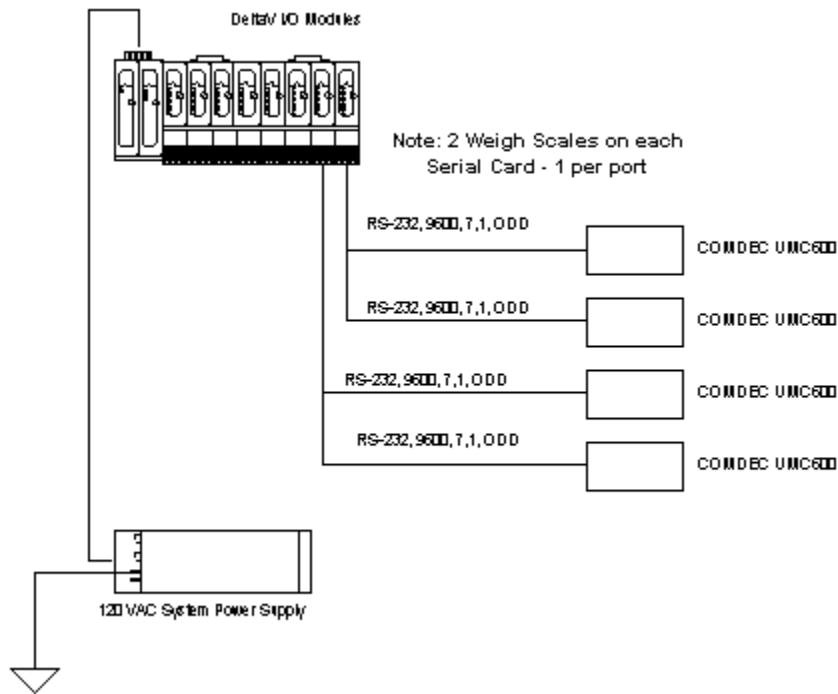



The RS-232 cable pinout is as follows. Note that if a NULL cable is required, swap pins 3 & 5 and 11 & 13 on the term block.

Term Block - Port1 Weigh Scale Device

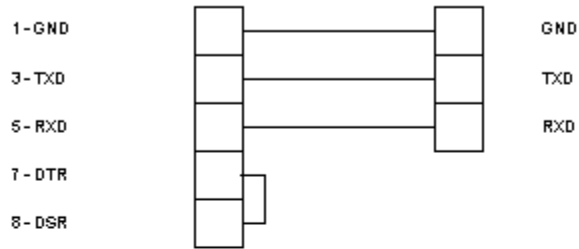

Term Block - Port2 Weigh Scale Device

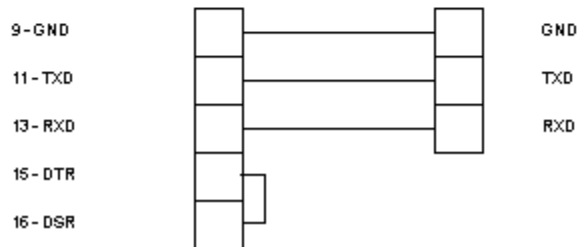



Serial Card Hookup – RS-485

The Programmable Serial Card can also be used to communicate with the Weigh Scales using RS-485. The following is an RS-485 hookup, with 2 serial cards. Each serial card supports 2 weigh scales, 1 per port. The distance between the serial card and the weigh scale can be as much as 5000 feet, per the RS-485 standard.

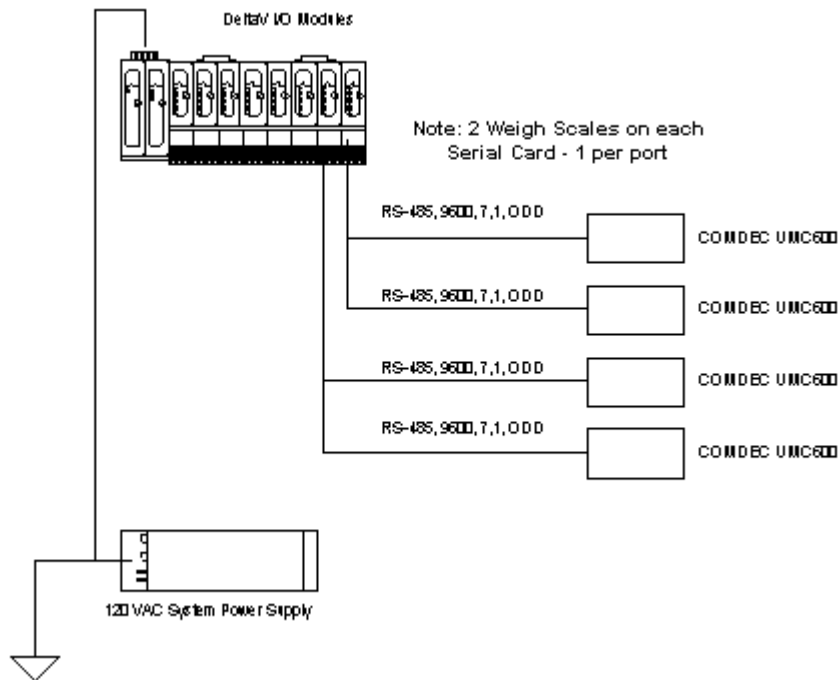

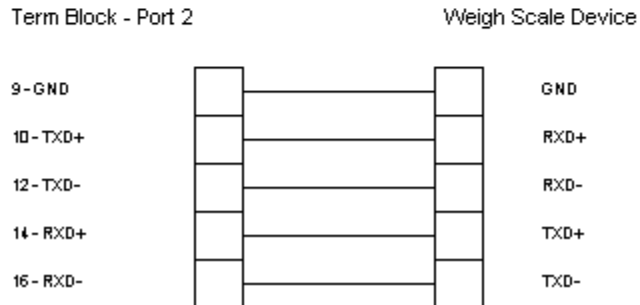
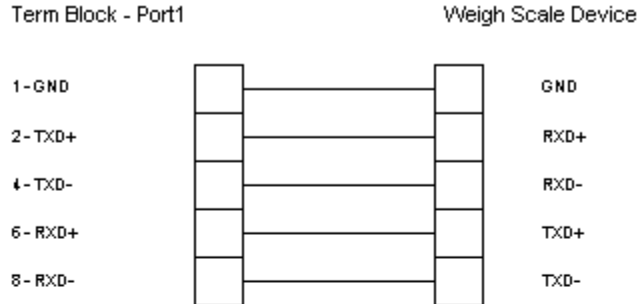

The RS-485 cable pinout is as follows.



Serial Card Hookup – RS-485 Multi-Drop

It may be possible to multi-drop all four weigh scales from a single port on a serial card. This would depend on whether the devices can be addressed uniquely. Such a hookup would be as follows:

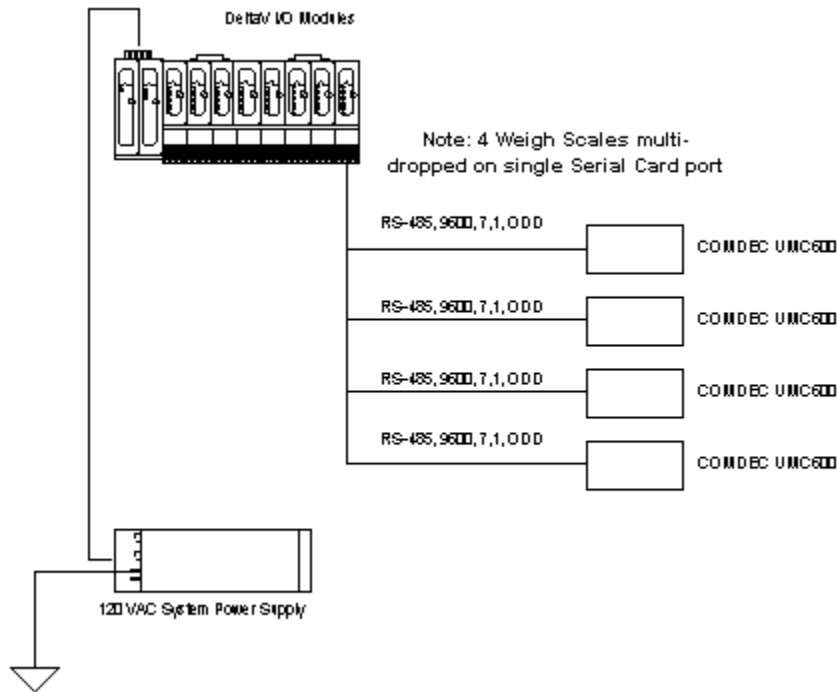

Using the Driver

To have the Programmable Serial Card communicate with the Weigh Scale, follow these steps:

1. In DeltaV, configure the serial card. This will create a Programmable Serial Card and define 2 ports under it, P01 and P02.

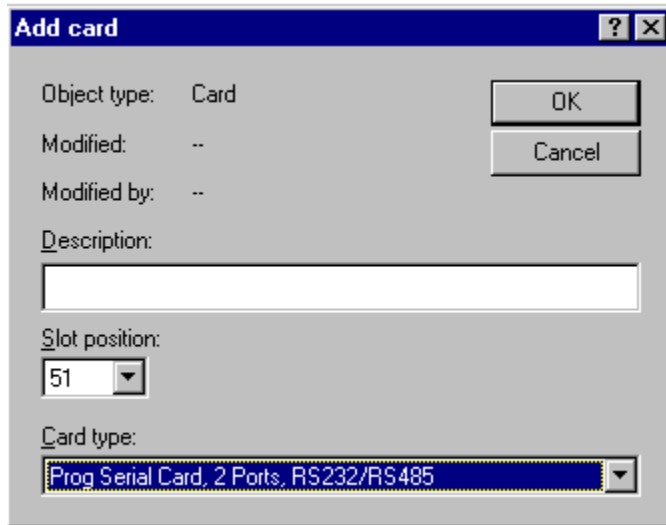

2. Right mouse click on Port 1. The following dialog will appear.

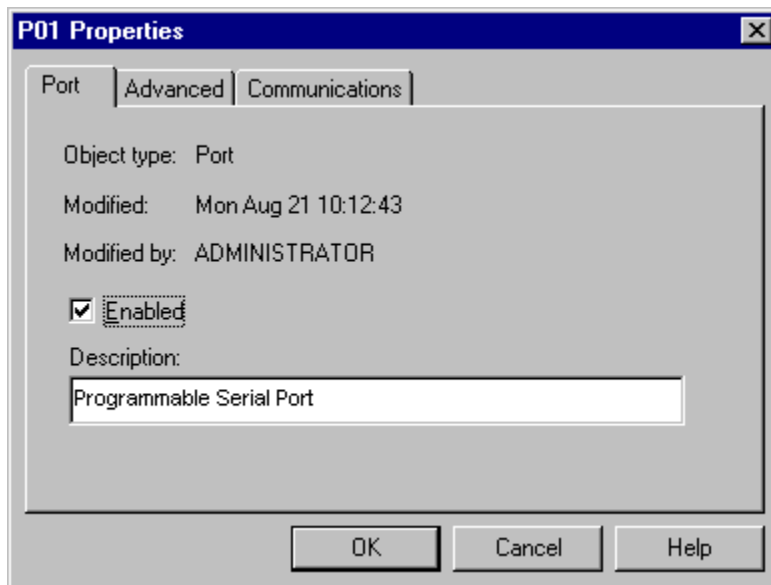



Click on the Enabled checkbox to enable the Port. Next select the Advanced tab. The following dialog will appear.

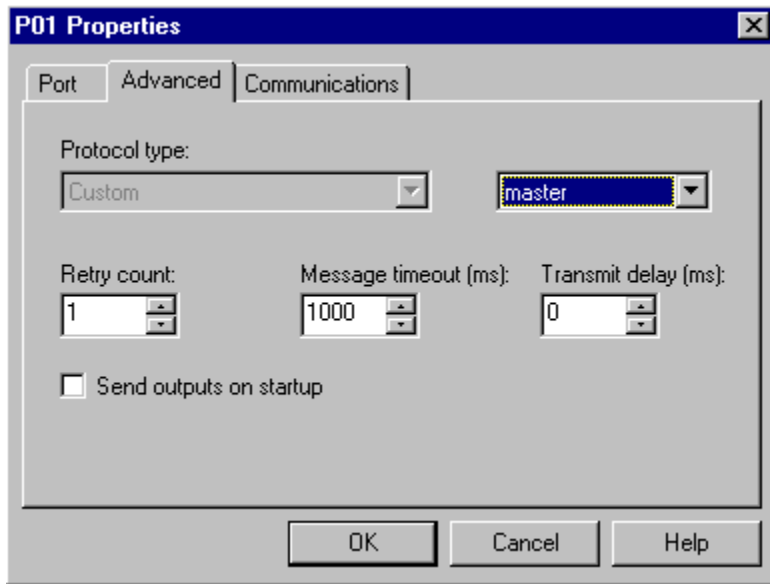

In this dialog, select Master since the card will be the master in communications. Also select the message time parameters. Next click the Communications tab. The following dialog will appear.

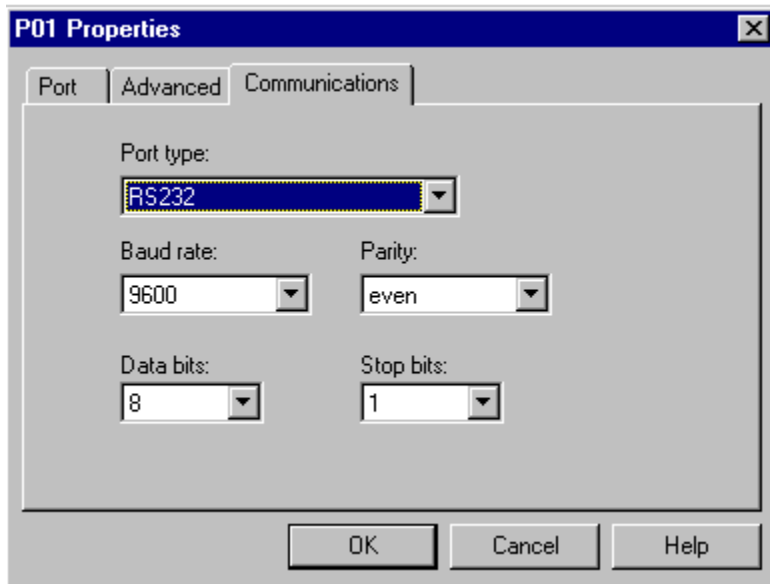

Specify Port type and the required baud rate parameters and click OK. The Port type will be RS232 or RS422/RS485 Full Duplex. Using RS422/RS485 allows greater distance between the



Serial card and the Weigh Scale. Furthermore, you can multi-drop Weigh Scales from the same port.

3. Configure a Serial Device under the Port by doing a Right Mouse click and selecting New Serial Device. The following dialog will appear:

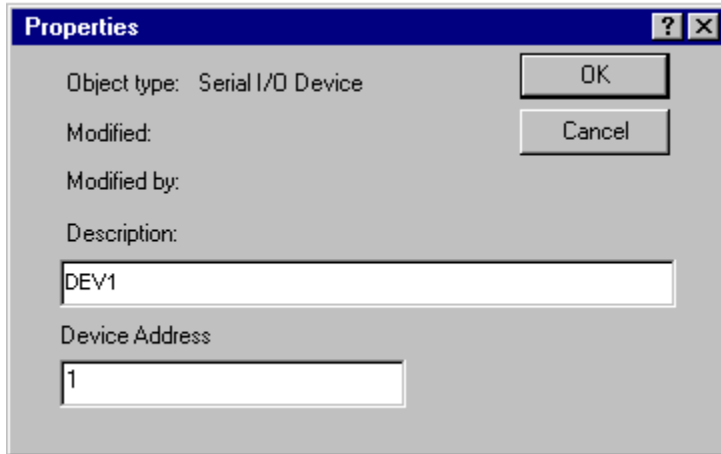

Specify the device address and description. Then click OK. This will add the serial device. You can define a maximum of 8 devices per port, representing 8 multi-dropped Weigh Scales. Address the devices 1-8. If only one Weigh Scale is attached, define only one device, addressed as 1.

4. Next, configure datasets in the Serial Device. For this application, each device must have 2 datasets under it. Both datasets will be of type Input. Dataset 1 will be have 2 values of type Floating point. Dataset 2 will have 4 values of type 8 bit Unsigned Int. To add a new dataset, right mouse click on the Serial Device and select New Dataset. The following dialog will appear.

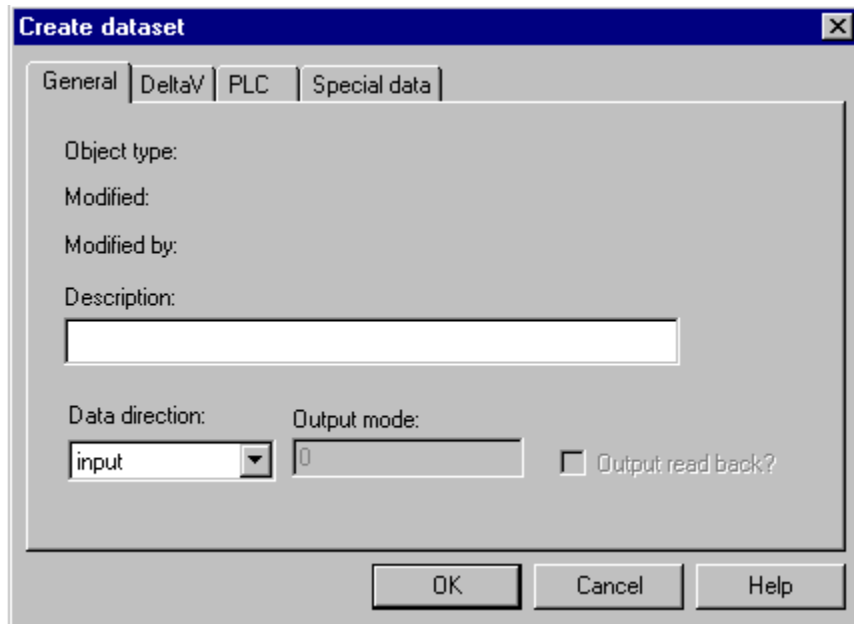

Configure the data direction to be input. Next click on the DeltaV tab. The following dialog will appear.

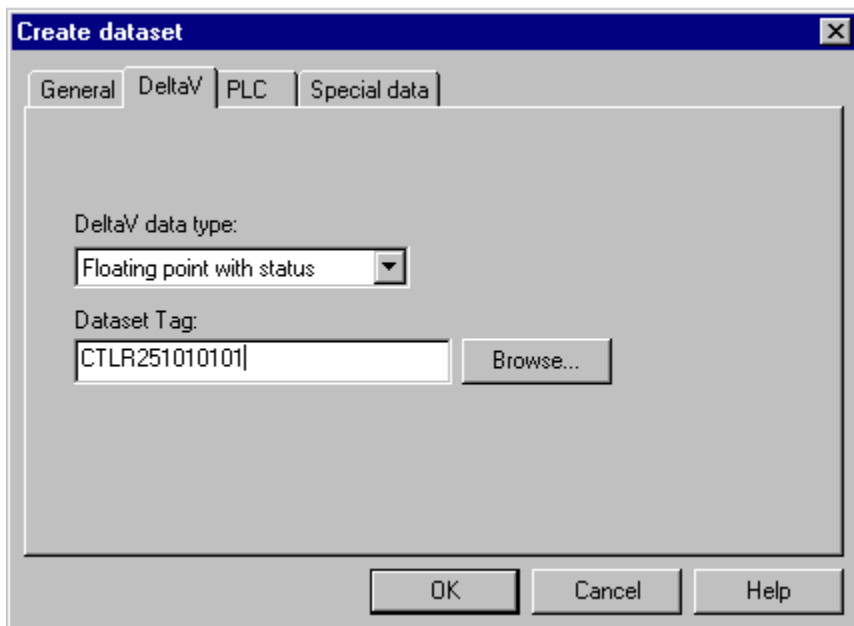

In this dialog, configure the data type needed for DeltaV. You can see the available types by clicking on the drop down list. Remember for this application, the first dataset data type is Floating point, and the second dataset data type is 8 bit Unsigned Int.



Next click the PLC tab. The following dialog will appear.

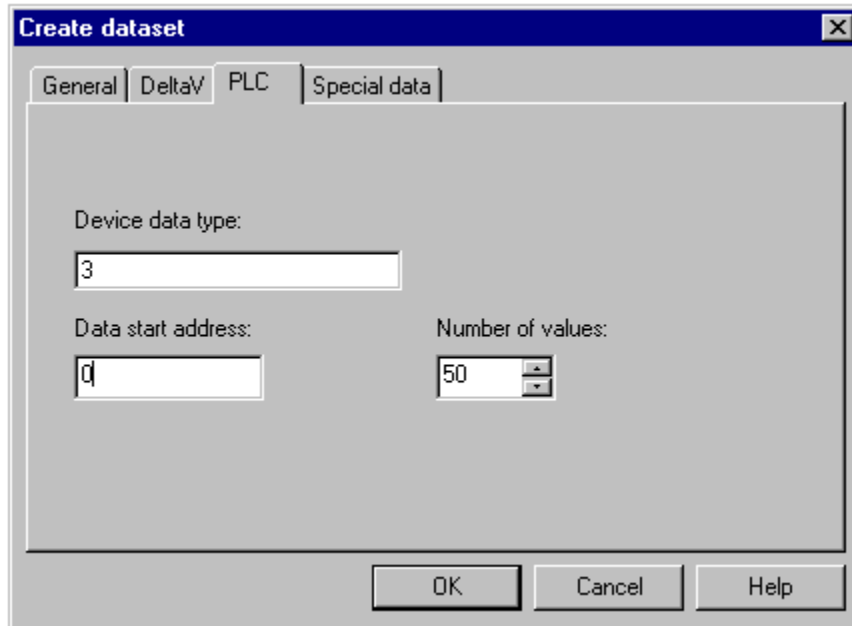

In this dialog, select the parameters as shown above for dataset 1. No parameters are defined under the Special data tab. Click OK to complete dataset definition. For dataset 2, select the parameters as shown below.

Driver Communications

The driver will continuously communicate with the Weigh Scales. This is known as the “Continuous” Mode of the Weigh Scales. In this mode, transmission occurs at the end of each display update.

If the communication parameters are setup as RS-232, then no commands are sent from the Serial Card to the Weigh Scale. The Serial Card simply receives the data packets, parses them out and makes the data available to DeltaV in the configured registers.

If the communication parameters are setup as RS-485, then the Serial Card will send out a poll command to the Weigh Scale. The Serial Card then receives the data packets, parses them out and makes the data available to DeltaV in the configured registers.

If there are communication errors, these are reported up to DeltaV. Errors are of two types:

1. Physical communication problems;
2. Status information received from the Weigh Scale.

Each weigh scale will always have only the following registers configured:

Data Name	Data Type	Assigned Register
Gross Weight	Floating Point	Dataset1-R1
Net Weight	Floating Point	Dataset1-R2
Gross Weight Units	Unsigned Integer 8	Dataset2-R1 1 – LBS 2 – KGS
Net Weight Units	Unsigned Integer 8	Dataset2-R2 1 – LBS 2 – KGS
Status	Unsigned Integer 8	Dataset2-R3
Error Code	Unsigned Integer 8	Dataset2-R4



The Status byte will be a bit mask defined as follows:

Status Bit	Value	Description
0	1	Digital Calibration
1	2	Analog Calibration
2	4	Invalid Data
3	8	Over/Under Range
4	16	Scale in Motion
5	32	Tare Recall data on Display
6	64	Setpoint #1 on Display
7	128	Setpoint #2 on Display

The bits are defined in order of priority, with bit 0 being the highest priority. A value of 0 indicates normal status.

The Error Code byte represents errors detected in the received messages. Most of these errors could be a result of mismatched communication parameters. These are defined as follows:

Error Code	Description
101	Invalid start of message detected. For continuous mode (RS-232), this should be a <STX>. For continuous mode (RS-484) response to poll, this should be a <:>. Instead some other character was received.
102	Invalid weigh units. The expected character for units is an <L> or <K>. This error code indicates that some other character value was received.
103	Invalid weigh type. The expected character for units is a <G> or <N>. This error code indicates that some other character value was received.
104	Invalid end of message. In RS-232 mode, the expected end of message is <CR><LF>. In RS-485 mode, the end of message is <CR>. The proper end of message byte(s) were not received.
105	Invalid status byte. Status byte should be one of the following: <D>,<A>,<I>,<O>,<M>,<Z>,<X>,<Y>,<SP>
106	Invalid polarity. The valid polarity indication is given by <-> for negative numbers and space for positive number. The received character did not match either.



Powerful Solutions for Digital Plants

Technical Support

For technical support or to report a defect, please give MYANH Technologies a call at (636) 681-1555. If a defect is discovered, please document it in as much detail as possible and then fax your report to us at (636) 681-1660.

For Product functionality questions, ask for the people in the following order:

1. Nobin William
2. Martin Berutti

For Commercial issues, ask for people in the following order:

1. Martin Berutti
2. Jane Wagner

For all other driver and related questions, ask for Nobin William.

You can also send us your questions via e-mail. Our addresses are:

Support@mynah.com

Thank you for using DeltaV.