

Allen-Bradley Driver for DeltaV Series 2 Programmable Serial Interface Card With Redundancy

USER MANUAL

November 2002

Rev. P1.12

Allen-Bradley and DeltaV are registered trademarks and DeltaV is a trademark of Emerson
© Emerson 1998, 1999, 2000, 2001. All rights reserved.

Printed in the U.S.A.

While this information is presented in good faith and believed to be accurate, Emerson does not guarantee satisfactory results from reliance upon such information. *Nothing contained herein is to be construed as a warranty or guarantee, express or implied, regarding the performance, merchantability, fitness or any other matter with respect to the products, nor as a recommendation to use any product or process in conflict with any patent.* Emerson reserves the right, without notice, to alter or improve the designs or specifications of the products described herein.



1 INTRODUCTION

1.1 Scope

This document is the User Manual for the Allen Bradley serial communication driver firmware for the Emerson DeltaV Control System; it provides information required to install, configure, and maintain the Allen-Bradley driver firmware on the DeltaV Series 2 Programmable Serial Interface Card (PSIC). The PSIC can be installed using redundant or simplex termination. The reader should be familiar with the DeltaV controller system and the Allen-Bradley PLC-5 Family of Programmable Logic Controllers and/or the Allen-Bradley SLC-500 Family of Serial Logic Controllers.

A DeltaV Programmable Serial Interface Card with the Allen-Bradley driver may communicate with the Allen-Bradley PLC-5 Family of Programmable Logic Controllers and/or the Allen-Bradley SLC-500 Family of Serial Logic Controllers within the constraints delineated herein. In general for driver version P1.0, the Allen-Bradley family of SLC-500's can communicate using the same command set used to communicate with the PLC-5 family. The SLC5/01 communicates via the PLC2 basic commands, so only file N9 can be accessed with the SLC5/01. For driver version P1.1, a specific command type was added to read/write SLC5/XX Input and Output tables. The current release of the driver, version P1.3, expands on the SLC specific command to read/write all SLC tables. Additionally, this version allows you to select communications using Half Duplex/CRC. Note that the default is Full Duplex/BCC. Version P1.4 is specific for Series 1 serial cards. Version P1.11 is for Series 2 Simplex serial cards, and Version P1.12 is for Series 2 Redundant serial cards.

The section *Document Format* briefly describes the contents of each section of this manual. *System Specifications* outlines hardware and software requirements for the Allen-Bradley Driver (P1.12) firmware. *Related Documents* lists other documents used to prepare this manual.

1.2 Document Format

This document is organized as follows:

Introduction	Describes the scope and purpose of this document
Theory of Operation	Provides a general functional overview of the Allen-Bradley Driver.
Downloading Firmware	Describes downloading procedures for the Allen-Bradley Driver firmware on to the DeltaV PSIC
PSIC Configuration	Describes procedures and guidelines for configuring the DeltaV PSIC
Operational Check	Provide tips and assistance to ensure PSIC is properly setup and configured
DeltaV-PLC/SLC	Describes the electrical interface between DeltaV and the PLC-5 or the SLC5/XX
Electrical Interface	Describes the pin assignments necessary for RS-232 and RS422/485 communications



1.3 System Specifications

The following table lists the minimum hardware requirements for the Allen-Bradley Driver:

Table 1: System Specifications

	Specifications
Firmware	Allen-Bradley Driver Firmware (P1.12)
Protocol	Allen-Bradley Protocol as defined in the documents:
Compatibility	Data Highway/Data Highway Plus™/DH-485 Communication Protocol and Command Set Reference Manual by Allen-Bradley
Software	DeltaV System Software (Release 3.1 or later) installed on a hardware- appropriate Windows NT workstation configured as a ProPlus for DeltaV
Requirements	Serial Interface Port License (VE4102)
Minimum	DeltaV PSIC Hardware PN: 12P2506X022 (Series 2 only)
Hardware	Simplex Term Block PN: 12P0921X012
Requirements	Redundant Term Block PN: 12P2565X012
	DeltaV M3, M5, M5Plus, or MD Controller, Power Supply and 2-wide controller carrier
	8-wide I/O card carrier
	Allen-Bradley PLC-5 Family of Programmable Logic Controllers or Allen-Bradley SLC5/XX family of Serial Logic Controllers or equivalent

1.4 Related Documents

The following documents were referenced either directly or indirectly in the development of this document:

- 96KH06.D01 - Type KJ3003 Serial Interface Hardware Specification
- 96KH05.D03 - DeltaV Programmable Serial Card Design Document
- DeltaV Programmable Serial Card Application Guide
- DeltaV Programmable Serial Card Allen-Bradley Data Highway Settings Rev 3
- Data Highway/Data Highway Plus™/DH-485 Communication Protocol and Command Set by Allen-Bradley
- 96KH05.D01 DeltaV Serial Card Design Document
- Allen-Bradley DF1 Protocol and Command Set Reference Manual
- Allen-Bradley Enhanced and Ethernet PLC-5 Programmable Controllers User Manual
- Allen-Bradley Software Configuration Manual
- Allen-Bradley Programming Manual
- Allen-Bradley Instruction Set Reference



2 THEORY OF OPERATION

As part of the serial interface port license, a standard Modbus protocol is installed on the DeltaV PSIC prior to customization. The PSIC needs to be flash upgraded from the Modbus protocol to the Allen-Bradley protocol before operation.

The Allen-Bradley serial driver implements DF1 protocol. It communicates with PLC-5 or SLC5/XX devices on the DH+ network through either a 1785-KE or 1770-KF2 communication modules. These modules convert the DF1 serial protocol to the DH+ network protocol. The switch settings must be configured properly for the RS-232 or RS-422/485 prerequisite for proper operation.

The Allen-Bradley Driver communicates with the PLC and updates emulated DeltaV I/O with the data received from the PLC. The primary functions of the driver are listed below:

- Performs data and message handling between DeltaV and PLC-5 / SLC5/XX.
- Sends messages to PLC-5 / SLC5/XX from DeltaV
- Processes reply information and updates the corresponding emulated DeltaV I/O channels
- Update emulated input channel status and Data Block status to indicate the communication state of PLC-5 / SLC5/XX.
- Checks validity of messages received by PLC-5 / SLC5/XX.

Upon proper installation and configuration of the Allen-Bradley driver within the DeltaV/PSIC system, communications with a properly configured Allen-Bradley PLC-5 or SLC5/XX may proceed.

There are a maximum of 16 Datasets (DS) per port, with a total of 32 per PSIC. The maximum number of data elements per Dataset that can be supported by the PSIC depends on the data file type. Note that the number of supported Datasets does not change. The following table describes this correlation:

Dataset Data File Type	Number of Data Elements
Boolean	100
Discrete	100
8-bit signed integer	100
16-bit signed integer	100
32-bit signed integer	50
8-bit unsigned integer	100
16-bit unsigned integer	100
32-bit unsigned integer	50
Floating point	50
String	1

The DeltaV PSIC is the master in all communications. It polls each input device and requests data values on a message-by-message basis. The output is performed when a new value is to be written to the devices. The PSIC constantly scans the configured input Datasets for new values and updates the database. Upon a change of value in the output Dataset, the PSIC will finish the current input scan and suspend the input process. It will service all the output requests before resuming the input process.

With the Allen-Bradley driver installed, the “Advanced” tab under port properties will allow selection of the configuration option for the port to act as a slave. This Allen-Bradley driver does not support slave functionality, so this configuration option is not valid.

The Allen-Bradley driver supports PLC-5 Logical ASCII and binary addressing, and SLC5/XX Protected Typed Logical addressing.



3 Downloading the firmware

To begin installation of the Allen-Bradley driver, create a folder on the hard drive. The preferred location for the folder is at C:\DeltaV\Ctl\ProgSerial\S2AllenBradley, although any location will work.

Next, copy the following files from the CD provided. The files are:

- Ab-manual.pdf
- 1200.idf
- 1395.idf
- IO_Compatibility.csv
- RedSerBoot.HEX
- RedSerReleaseApp.HEX
- RedSerReleaseProgApp.hex
- s2ab.s2f
- S2RedAllenBradleyApp.hex
- SampleCustomProtocol.s2f
- SampleCustomProtocol.sdf
- SerBoot.hex
- SerReleaseApp.HEX
- SerReleaseProgApp.HEX
- StandardModbusApp.s2f
- StandardModbusApp.sdf

Once the files have been copied to the appropriate folder, the process of downloading the driver can begin:

1. Start the "Controller Upgrade Utility" from the DeltaV/Installation menu
2. Select "Upgrade I/O Modules" and engage the "Next" button
3. From the controller list select the controller to which the serial card is attached and enter the "Next" button
4. Find the list of I/O cards connected to the selected controller. At the bottom of the screen there is an upgrade file path displayed. Enter the "Browse" button and browse to the directory containing the Allen-Bradley driver. This should be C:\DeltaV\Ctl\ProgSerial\S2AllenBradley. Engage the "OK" button to return to the I/O card selection screen
5. Select the Serial Card or Prog Serial Card to be upgraded
6. If the user chooses a standard Serial Card to be upgraded then the card will automatically be upgraded as soon as the "Next" button is entered. If the user chooses a Prog Serial Card, the user will be prompted for the S2F file to use. Browse to and select the proper SDF file. Press the "Open" button followed the "Next" button to start the upgrade process
7. The Flash Upgrade process should start and the progress will be displayed in the progress window. An upgrade complete message will be displayed upon completion of the upgrade.
8. If a standard Serial Card was used for this installation, delete the Serial Card in DeltaV Explorer and Auto-sense the new Prog Serial Card. Installing a special driver changes the card from a standard Serial Card to a Prog Serial Card.



4 CONFIGURATION INFORMATION

This section describes the steps necessary to configure the DeltaV PSIC and the Allen-Bradley PLC such that communications may be invoked

4.1 Channel Attributes Block of PSIC

Channel Attributes Block

For the PSIC configuration, there is one channel attributes block per Dataset. There can be up to 16 Datasets configured per port for a total of 32 Channel Attribute Blocks per Serial Card. Each Channel Attribute Block contains all the configuration information for a single configured PSIC Dataset.

The four following attributes (page 9) are unique to the Allen-Bradley Data Highway serial card. All other values are as per the standard serial interface card. Information for the standard serial interface card can be found in *DeltaV Books Online*, under the title "Using Serial Data Control Strategies".



Attribute	Defined Values
<p>DeviceDataType</p>	<p>0 = Basic Protected 1 = Basic Protected Bit 2 = Basic Unprotected 3 = Basic Unprotected Bit 4 = PLC-5 Typed (Logical ASCII Addressing) 5 = PLC-5 Ranged (Logical ASCII Addressing) 6 = Diagnostic 7 = PLC-5 Read-Mod-Write (Logical ASCII Addressing) 8 = PLC-5 Typed (Logical Binary Addressing) 9 = PLC-5 Ranged (Logical Binary Addressing) 10 = PLC-5 Read-Mod-Write (Logical Binary Addressing) 11 = SLC 500, SLC 5/03 and SLC 5/04 Protected Typed Logical Read/Write with three address fields</p>
<p>SpecialData1 (PLC-5 /SLC File Type)</p>	<p>This Field is "Don't Care" for DeviceDataType 0-3, and 6</p> <p>0 = Output File Type, O 1 = Input File Type, I 2 = Status File Type, S 3 = Binary File Type, B 4 = Timer File Type, T * 5 = Counter File Type, C * 6 = Control File Type, R * 7 = Integer File Type, N 8 = Floating File Type, F</p> <p>* Timer, Counter and Control types are not available in this driver at this time when communicating with a PLC-5.</p>
<p>SpecialData2 (PLC-5 /SLC File Number)</p>	<p>This field is "Don't Care" for DeviceDataType 0-3, 6</p> <p>0 – 65535 file number</p> <p>0 - 8 are reserved to match with file types in SpecialData1</p>
<p>SpecialData3</p>	<p>Specify 0 for DF1 with Full Duplex and BCC</p> <p>Specify 1 for DF1 with Half Duplex and CRC</p>



4.2 Device And Dataset Configuration

The following paragraphs discuss some attributes in the device and Dataset configuration:

4.2.1 Device Address:

The device address attribute is located in the device configuration box under port. It is the PLC/SLC node address, not the 1785-KE or 1770-KF2 communication module address. This number is used by DeltaV to uniquely identify each PLC in the Data Highway Plus network. The PLC node address is an octal-based number set with dip switches on the PLC. Therefore, it needs to be converted to a decimal number in the serial card configuration. For example, an octal address of 10 on the PLC corresponds to a decimal address of 8 in the serial card. The acceptable address range is between 1 and 255.

4.2.2 Output Mode:

Two output modes are available in the driver: block output (0) and single output (1). In typed or ranged transaction (DeviceDataType 4,5,8, and 9), the block output mode writes the entire data block for every output data value change. Therefore, it is undesirable to contain any foreign-device-controlled (device other than DeltaV) values within the block. For example, if a PLC-5 memory N7:5 is written by a PLC-2, and user defines a Dataset with a range of N7:0 to N7:10 in block output mode, an output operation will overwrite the N7:5 with the value in the DeltaV database.

Single output mode allows individual value to be sent out, leaving other values in the Dataset unaffected. In the binary file type, word value is treated as a single value. It does not allow user to write a specific bit within a word. Therefore, the entire 16 bit will be written when a single discrete output value changes. When communication with a PLC-5, writing single bit values in a multi-bit Dataset can be achieved with Read-Modify-Write (RMW) transaction (DeviceDataType 7 and 10). The RMW is used only with binary file type and single output mode. Each bit can be set or reset within a binary file without affecting other bits in the same word. This command is not available under the SLC5/XX architecture.

4.2.3 DeviceDataType

This attribute defines what type of transaction will be performed for the Dataset between the PSIC and the Allen-Bradley device. Values from 0 to 11 are listed in the above table. They are briefly described below:



Types 0 – 3 (Basic Commands):

These are mainly for PLC-5 backward compatibility to older types of PLC with non-paged memory like PLC-2. The special data fields are not used during configuration. All data (16-bit integer or discrete) are written/read through the PLC-2 compatibility file. The memory address in PLC-5 is assigned with the communication module address. This address is an octal based number which can be set with dip switches on the module. For example, if the KE module has an address of 13 octal (11 decimal), data will be accessed from PLC-5 integer file N11.

The Basic Protected (0) and Basic Unprotected (2) use word address to operate on integer data. The Basic Protected Bit (1) and Basic Unprotected Bit (3) use byte address to operate on discrete or binary data. Since the addressing scheme differs between Basic word and Basic bit commands, the user needs to be cautious in specifying the starting address in the Dataset. For example, if user wants to access bit 0 in word 10 (N11:10), the starting address needs to be 20 to convert word address into byte address. All four commands support both single and block output mode. In single output mode, only the changed bits will be written in addressed byte for Basic Bit write.

Types 4 (Typed Transaction with ASCII addressing) and 8 (Typed Transaction with binary addressing):

The typed transactions treat each data type as an element and automatically adjust the memory address to accommodate the defined element type. Therefore, the starting address points to different memory location depending on the data type. It points to the word address for integer data and double word address for floating point data.

For Binary data type, it points to the word, not the bit, address within the Binary file. The number of element denotes the number of bits to be included in the Dataset starting at the specified word address. The bit position is relative to the starting word address. Therefore, every seventeenth bit will start at the next word. For example, a starting address of 8 with 32 elements means the Dataset starts at the eighth word in the binary file and contains 32 bits. The seventeenth bit will start at the ninth word. The bit position in the PLC is specified by a slash (/) after the word address. Therefore, the first bit in the above Dataset has an address of B3:8/0. Although each Dataset can contain 100 elements, it is recommended that the maximum number to be 96 to ensure the Dataset ends on a word address boundary.

Both single and block output modes are supported for integer, binary, and floating point file type.



Types 5 (Ranged Transaction with ASCII addressing) and 9 (Ranged Transaction with binary addressing):

Unlike Typed operations that automatically adjust the memory address to accommodate the defined element type, the Ranged operations use word address exclusively. It performs consecutive memory word read and write. The driver takes care of address adjustment for floating point file type, making it transparent to the user and DeltaV. Therefore, the Ranged operation on integer, binary, and floating point file types are the same as the Typed operation.

Both single and block output modes are supported for integer, binary, and floating point file type.

Unlike the Typed read which only accesses the accumulator or position attribute, the Ranged read always starts at the first attribute and includes all three attributes in the data file.

Types 7 (Read-Modify-Write with ASCII addressing) and 10 (Read-Modify-Write with binary addressing):

When communicating with a PLC-5, Read-Modify-Write (RMW) is used to set/reset a single bit in the binary file. User can set any bit in the Dataset. It is different from writing to the binary file with Typed write. The Typed write will write all 16 bits in the word. The RMW let user write a single bit in any word, leaving other bit unaffected. The block output mode is not supported in RMW. Therefore, single output mode (1) must be used with RMW.

RMW is for output only. The data direction parameter in the Dataset configuration must be "output". Configuring RMW as input to PSIC will cause error and undesirable results.

Type 11 (SLC 500, SLC 5/03 and SLC 5/04 Protected Typed Logical Read/Write with three address fields):

This DeviceDataType is used to read/write all available tables (including the Input and Output tables) of the SLC processors listed. The reads and writes are from/to the logical address generated based on the starting address of the dataset. The following describes the parameters and their usage:

Input, Output, and Binary tables can be defined as Boolean, Discrete or 16-bit UINT. When using Boolean or Discrete, the starting address is always a 16-bit word address (0, 16, 32, etc), and the Number of Values refers to bits. For example, a Dataset with starting address at 0 and 32 values gives you 32 bits. When using 16-bit UINT, the starting address can be anywhere in the table, and the Number of Values refers to 16-bit registers.

Input tables are read only. Output tables can be read and written. When performing reads/writes to the Output table, the driver will access the SLC on a 16-bit word basis. If the Output mode in DeltaV is 0 (i.e., Block), the entire block will be written if any bit in the Dataset changes. On the other hand, if the Output mode is 1 (i.e., Single Value), then on a single bit change, the 16-bit word containing that bit will be written.

For floating point values, the starting address refers to the register number and a 4 byte value is read/written. For all other tables, the starting address refers to the register number and a 2 byte value is read/written.



Notes:

- DeviceDataTypes 7 and 10 are only valid with file type 3 and output mode 1.
- Output Modes : 0- block output; 1- single data output
- PLC 5/XX Binary File Types only work in output mode 0, block outputs. To write single bit values in a multi-bit dataset use DeviceDataType 7 or 10 with output mode 1.
- Floating Point file types, 32-bit Integer, and 32-bit unsigned Integer require 2 16-bit registers per value, thus reducing the registers per dataset to 50 (maximum 16-bit registers per dataset is 100).
- When addressing registers, DeltaV PSIC register numbers are 1 based, whereas PLC and SLC registers are 0 based.



Dataset properties [X]

General | DeltaV | PLC | Special data

Object type: Dataset
Modified: Wed Nov 11 09:59:58
Modified by: ADMINISTRATOR

Description:
DataSet01

Data direction: Output mode: Output read back?

OK Cancel Help

Dataset properties [X]

General | DeltaV | PLC | Special data

DeltaV data type:

Dataset Tag:
 Browse...

OK Cancel Help

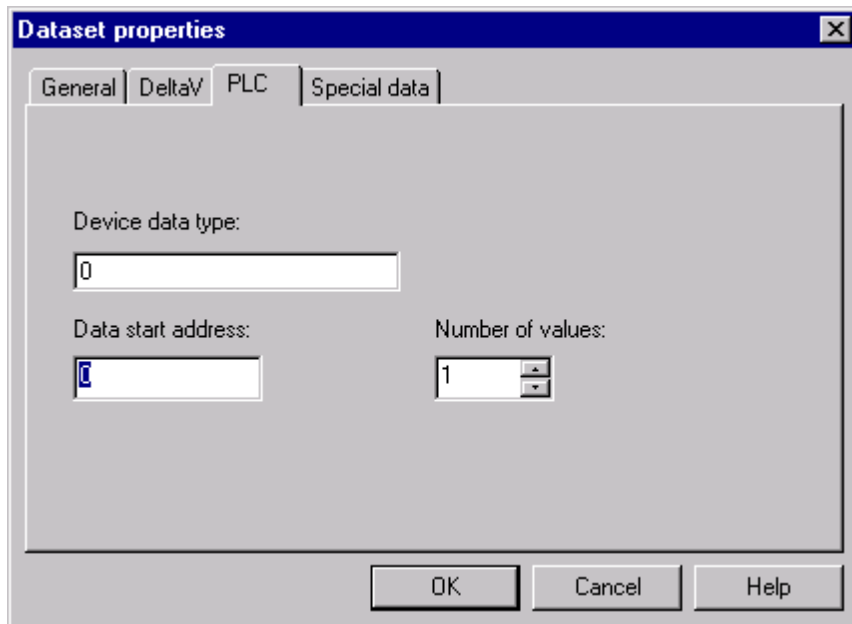
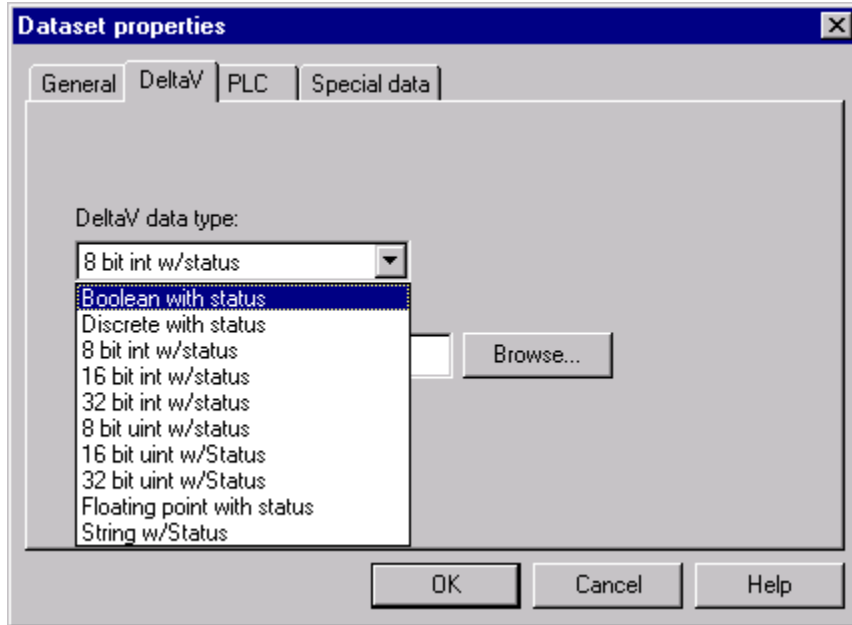

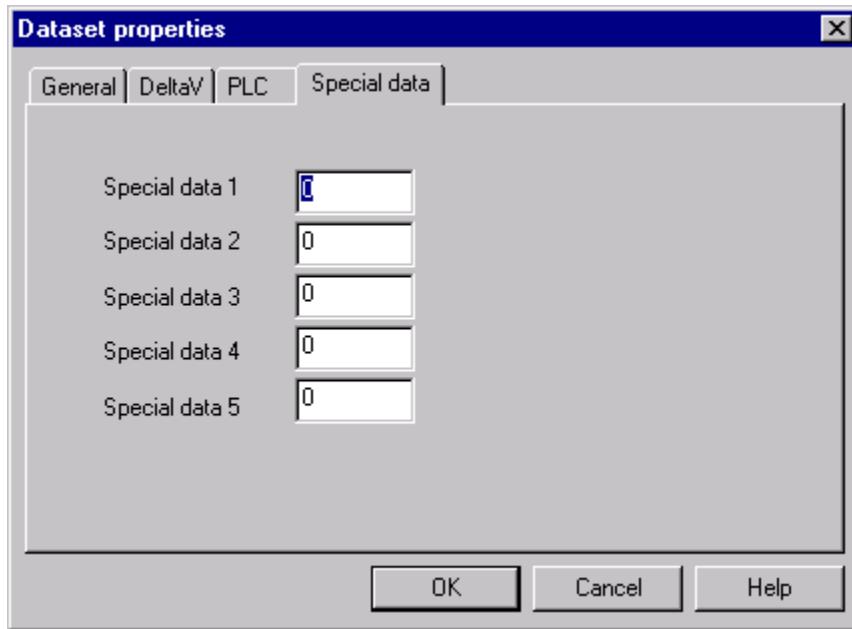

4.4 Serial Port Configuration for DeltaV PSIC

In order for proper communication between the Programmable Serial Interface Card and the Allen-Bradley PLC, the serial port settings on both devices must be configured properly.

The PSIC serial port can be configured via a combination of the following settings through the DeltaV Explorer Menu using the Properties box.

- Protocol Type Custom
- Mode Master
- Retry Count 0 to 255
- Message time-out 100 to 25500ms
- Transmit Delay 0 to 25500ms
- Send Outputs on Startup Yes or No
- Port Type RS-232, RS-422/485 Half - Duplex, RS - 422/485 Full - Duplex
- Baud Rate 300, 1200, 2400, 4800, 9600, 38400, 57600, 115200
- Parity None, Even or Odd
- Data Bits 7 or 8
- Stop Bits 1 or 2



5 Operational Check

5.1 Scope

The following sections provide some assistance to ensure the interface is working properly.

5.2 Verify Hardware and Software Version Number

The user can verify that the AB driver has been installed using the DeltaV Diagnostics tool. The Diagnostics tool will show the Hardware Revision No. (HwRev) and the Software Revision No. (SwRev).

To begin the DeltaV Diagnostic tool select Start-> DeltaV-> Operator-> Diagnostics. In the Diagnostics tool expand the Controller, I/O and then double click on the Programmable Serial Interface Card that has the Allen-Bradley driver installed.

The following information will be displayed:

:	:	:
HwRev	Hardware Revision	1.1 (or later)
SwRev	Software Revision	P1.0 (or later)

5.3 Verify Configuration

- Verify port configuration: The serial port must be enabled. User needs to make sure communication settings such as baud rate, parity, and number of data bits match the Allen-Bradley device settings.
- Verify device configuration: User must check for the proper device address is entered. The Allen-Bradley device address is an octal-based number. This number must be converted to a decimal number.
- Verify Dataset configuration: The RMW operations are output-only commands. Do not configure input Dataset with RMW. The DeltaV data type also needs to match with Allen-Bradley data types. For example, user should not match a DeltaV 16-bit unsigned integer with a PLC-5 floating point file data. Unpredictable results will occur if there is a mismatch between the two data types. The starting address should always be an even number to ensure proper word boundary is assigned. For Special Data 2, number 0 through 8 must match the default Allen-Bradley file types.



5.4 Verify I/O Communication With Control Studio

- User can create I/O modules in the control studio to verify correct values are read and written between the foreign device into the PSIC. For input data, the values should be changed in the foreign device and verified that the new data are correctly reported. For output data, change the values in the controller and then verify that the values are transferred to the foreign device.
- To assign a Dataset and a register in the Dataset to an I/O module, follow these steps:
 1. Double click the IO_IN/IO_OUT parameter for the module. This brings up the IO_IN/IO_OUT Property window.
 2. Click on the Browse button. This brings up the Browse window.
 3. Click on the Object_Type drop down list, select All. This displays all the Dataset tags.
 4. Double click on the desired Dataset tag. This assigns the tag to the module and closes the Browse window.
 5. Choose the desired register in the Parameter drop down list.
 6. Click the OK button.
- For output modules, user also needs to change the MODE parameter to Manual for Normal Mode and Target.

5.5 Using Diagnostics

- Verify PSIC communication: Select the PSIC on Diagnostics and press the right mouse button. Select Display Real -Time Statistics from the drop down menu. If the Programmable Serial Interface Card is functioning then the user will see the Valid Responses counter and the Async and/or Sync Transactions counters incrementing. There will not be any error counting up. This method checks the railbus communications between the serial card and the DeltaV controller.
- Verify port statistics: Select the Port on the Programmable Serial Interface Card and press the right mouse button. Then select Display Port Statistics form the drop down menu. Verify that the port communications statistics are being displayed properly and are counting as expected for the Allen-Bradley protocol's functionality.
- Verify Dataset values: Select a Dataset and press the right mouse button. Select View Dataset Registers from the Drop down window. Verify that the Dataset values are displayed as expected.

5.6 LED Indication

The Yellow LED for the port should be on solid when all communications on that port are valid. The Yellow LED should be blinking if there is some valid communications and some communications with errors on that port. The Yellow LED should be OFF if there are no valid communications on that port.



6 DeltaV – PLC/SLC Electrical Interface

The electrical interface between DeltaV and the PLC-5 and SLC 5/XX conforms to the RS-232 protocol and RS-422/485 protocol. The cabling should not exceed 50 feet for the RS-232 protocol or 4000 feet for the RS-422/485 protocol.

In 6.1 and 6.2 the pin assignments for the PSIC Serial Terminal Block are listed for the RS-232 protocol and the RS-422/485 protocol. Pins 1 - 8 are for Port 1 connections and Pins 9 - 16 are for Port 2 connections

6.1 RS-232 Pin Assignments for DeltaV PSIC

Terminal Number	Signal Description
1	Port 1 - Isolated Ground (GND)
2	Unused
3	Port 1 - Transmit Data (TXD)
4	Unused
5	Port 1 - Receive Data (RXD)
6	Unused
7	Port 1 - Data Terminal Ready (DTR)
8	Port 1 - Dataset Ready (DSR)
9	Port 2 - Isolated Ground (GND)
10	Unused
11	Port 2 - Transmit Data (TXD)
12	Unused
13	Port 2 - Receive Data (RXD)
14	Unused
15	Port 2 - Data Terminal Ready (DTR)
16	Port 2 - Dataset Ready (DSR)



6.2 RS-422/485 Pin Assignments for DeltaV PSIC

Terminal Number	Signal Description
1	Port 1 - Isolated Ground (GND)
2	Port 1 Half Duplex Data+/Full Duplex TXD+
3	Unused
4	Port 1 - Half Duplex Data -/ Full Duplex TXD-
5	Unused
6	Port 1 - Full Duplex RXD+
7	Unused
8	Port 1 - Full Duplex RXD-
9	Port 2 - Isolated Ground (GND)
10	Port 2 - Half Duplex Data+ / Full Duplex TXD+
11	Unused
12	Port 2 - Half Duplex Data-/ Full Duplex TXD-
13	Unused
14	Port 2 - Full Duplex RXD+
15	Unused
16	Port 2 - Full Duplex RXD-



6.3 Wiring Connections for RS-232 Communications

The figure below shows the connections between the 1785-KE module RS-232 port and the serial card I/O termination block.

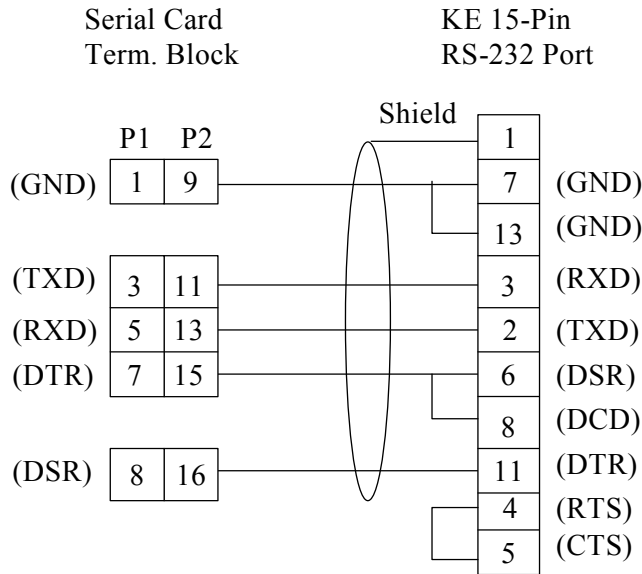

The figure below shows the connections between the 1770-KF2 module RS-232 port and the serial card I/O termination block.

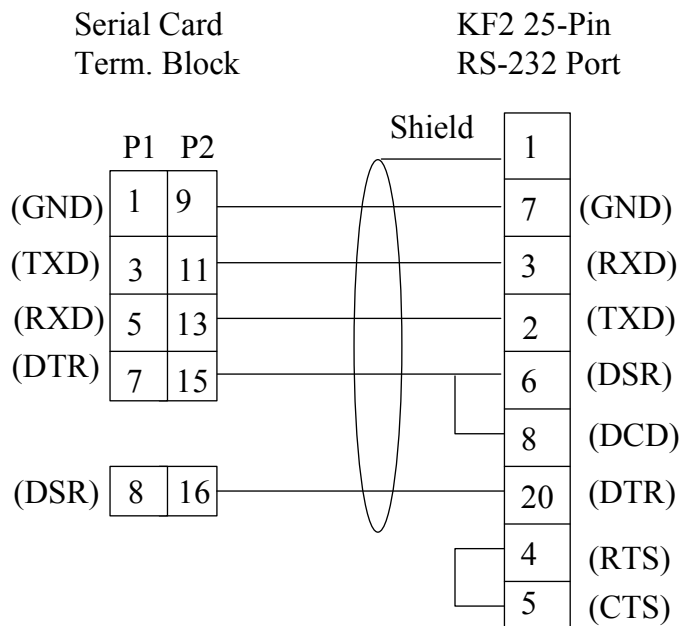



The figure below shows the connections between the Channel 0 Port of a PLC-5 and the serial card I/O termination block.

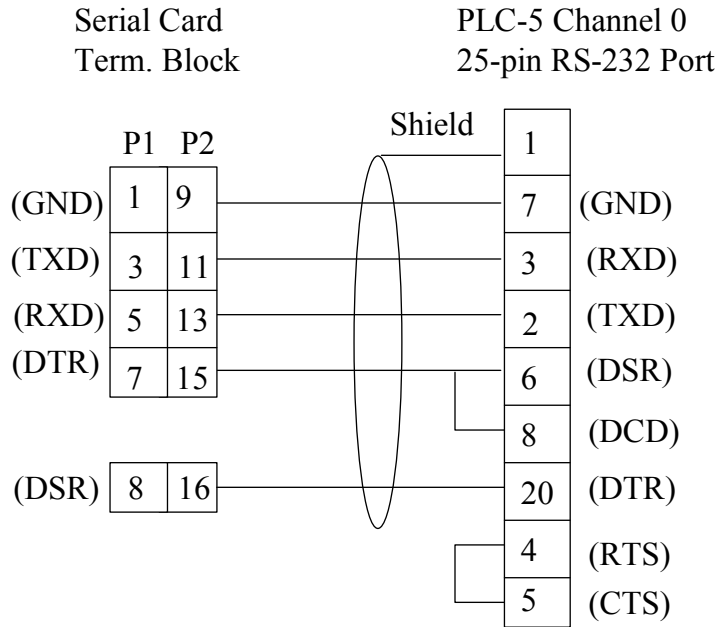

The figure below shows the connections between the Channel 0 Port of a SLC5/XX and the serial card I/O termination block. Optionally, you can jumper 4 and 6 on the SLC side, and 7 to 8 and 15 to 16 on the Serial card side.

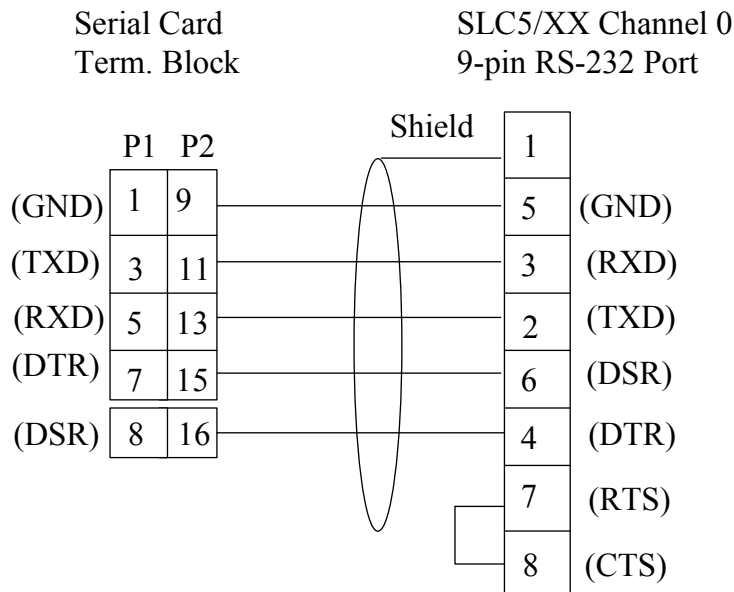



6.4 Wiring Connections for Simplex Communications

The figure below shows simplex communication connections between the DeltaV Serial card and the Allen Bradley PLC's. Note that you must use the simplex termination block with the serial card.

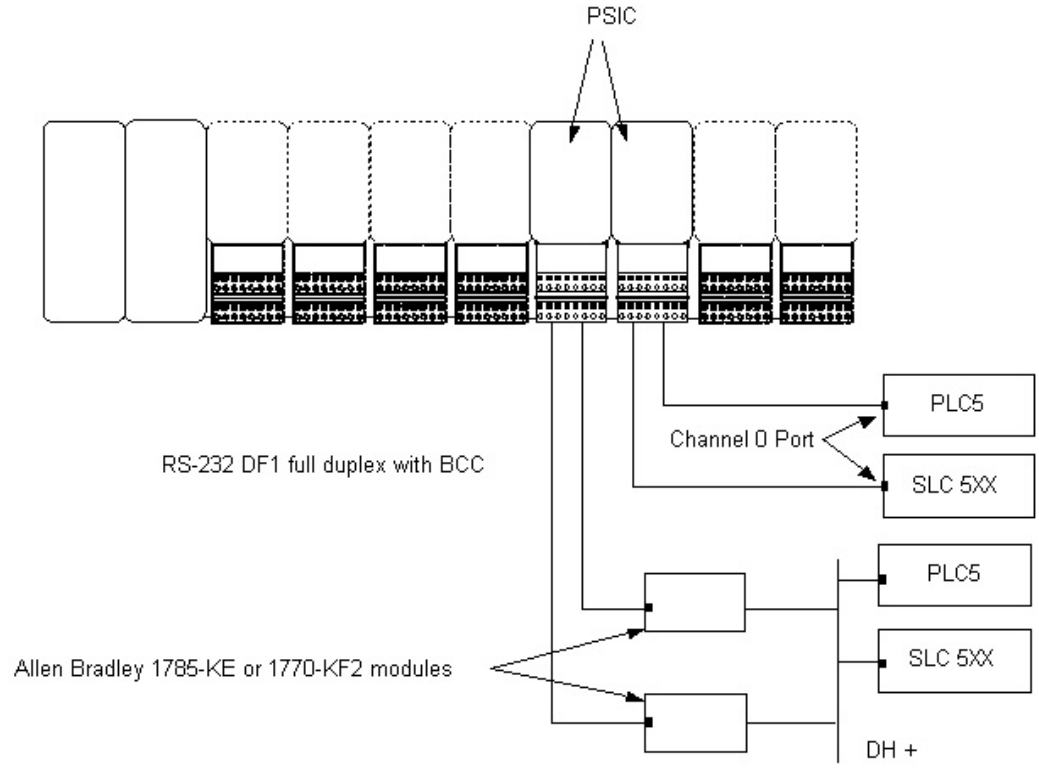

The figure below shows simplex communication connections between the DeltaV Serial card and the Allen Bradley devices residing on a DH485 network.. Note that you must use the simplex termination block with the serial card.

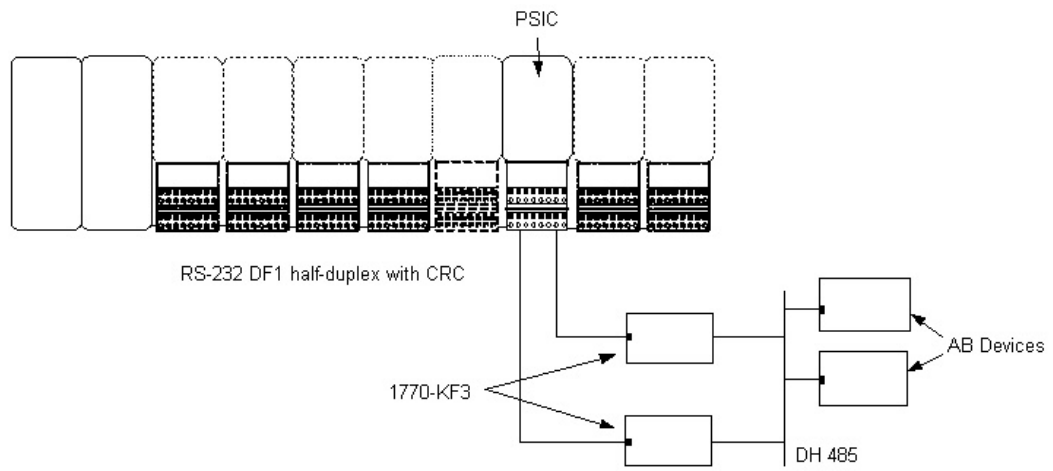



6.5 Wiring Connections for Redundant Communications

The figure below shows redundant communication connections between the DeltaV Serial card and the Allen Bradley PLC's. Note that you must use the redundant termination block with the serial card.

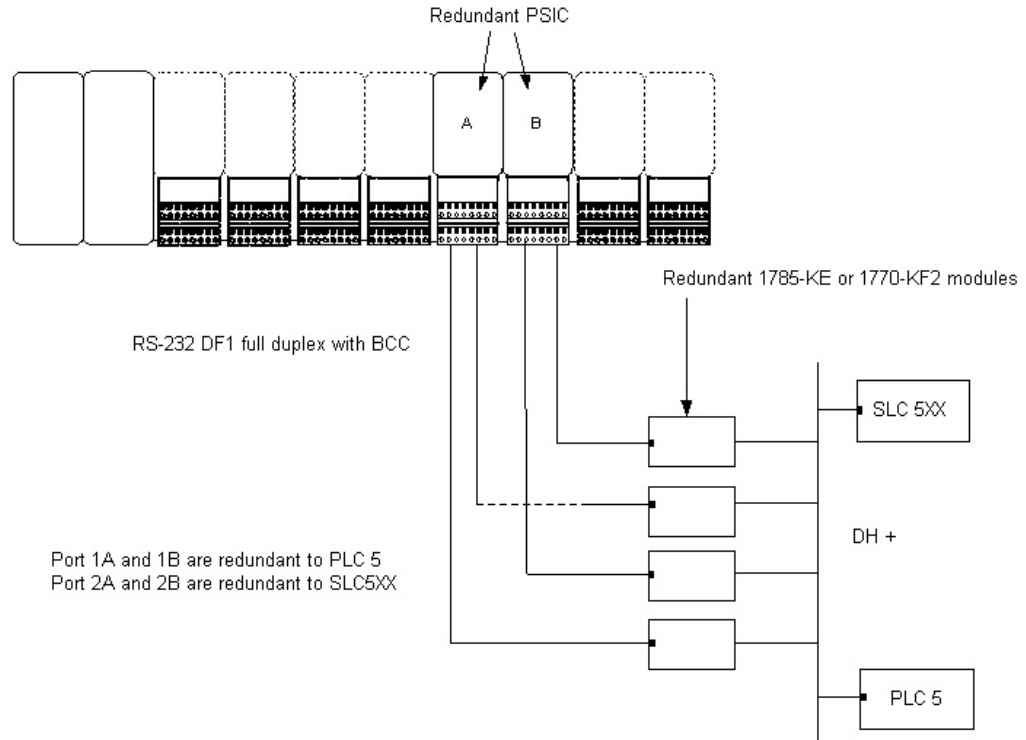



Appendix A Module Settings

Appendix A discusses the necessary settings for 2 gateway modules. The 1785-KE module, Series A and B, and the 1771-KE and 1771-KF modules.

A.1 1785-KE Module (Series A) Switch Settings

The 1785-KE module (Series A) has 6 switch assemblies which allow the selection of various communications options. The 1785-KE Module RS-232 parameters should be set up as follows:

- Full duplex
- Same parity as configured for the DeltaV PSIC Port
- BCC error checking
- Data Highway Plus communications baud rate of 57.6 K
- RS-232C communications baud rate same as DeltaV PSIC port
- Execute diagnostic commands

There are additional switches on the 1785-KE module (Series A) which may require adjustment. Refer to the Allen-Bradley User Manual for further information.

- SW1 - RS-232C link
- SW2 - Not used (Switches must be off)
- SW3/SW4 - Node Number
- SW5 - Network link communication baud rate
- SW6 - RS232C link communication rate and diagnostic commands

A.2 1785-KE Module (Series B) Switch Settings

The 1785-KE (Series B) has 4 switch assemblies which allow the selection of various communications options. The 1785-KE Module RS-232C parameters should be defined as follows:

- Full duplex
- Same parity as configured for the DeltaV PSIC port
- BCC error checking
- Data Highway Plus communications baud rate of 57.6K
- RS-232C communications baud rate same as configured for DeltaV PSIC port
- Execute diagnostic commands

There are additional switches on the 1785-KE Module (Series B) which may require adjustment. Refer to the Allen-Bradley User Manual for further information.

- SW1 - RS232C link features
- SW2 - Node number



- SW3 - Data highway Plus and RS-232C communication baud rates, and Local/Remote option
- SW4 - Reserved for future use.

A.3 1770-KF2 Module Switch Settings

The 1770-KF2 module has 6 switch assemblies which allow the selection of various communications options. The 1770-KF2 Module RS-232C parameters should be set up as follows:

- Full duplex
- Same parity as configured for the DeltaV PSIC Port
- BCC error checking
- Data Highway communications baud rate at 57.6k
- RS-232 communications baud rate same as DeltaV PSIC Port
- Execute diagnostic commands

There are additional switches on the 1770-KF2 module which may require adjustment. Refer to the Allen-Bradley User Manual for further information.

- SW1 - RS-232C link
- SW2/SW3/SW4 - Station number
- SW5 - Data highway communication baud rate
- SW6 – Computer link baud rate and diagnostic commands
- SW7 – Spare

**NOTES: Dip switch changes do not take affect until power is cycled on the KF2.
The fourth switch on SW1 must be set to ON. This enables hardware handshaking.**